

Vacuum ejector with vacuum burst function

VSY Series

- Nozzle diameter: $\varnothing 0.5$, $\varnothing 0.7$
- Integration of the ejector and vacuum burst function achieves high speed suction and burst cycle.



Features

- Compact and lightweight, it can be used at the end of vacuum piping. Also, the shutoff valve achieves high-speed suction and burst cycle.
- With additional function to release burst air to the ejector. It is capable of reliable vacuum burst compared to the conventional single ejector.
- Ejector and vacuum burst function are integrated. Switch between vacuum generation and burst air by turning the ejector air supply ON/OFF. (Refer to Usage methods on page 13.)

Specifications

Descriptions	VSY
Working fluid	Air
Working pressure MPa	0.3 to 0.7
Ambient/fluid temperatures °C	5 to 50
Lubrication	Not required

Vacuum filter specifications

Descriptions	Vacuum filter
Working fluid	Air
Working pressure kPa	-100 to 0
Filtration rating μm	10
Ambient/fluid temperatures °C	0 to 60
Filtration area cm^2	Port size $\varnothing 4$: 0.8 Port size $\varnothing 6$: 1.1

Circuit diagram

- VSY-*S (atmospheric release with silencer)

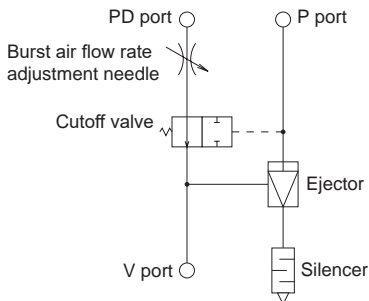

- VSY-*S-F (atmospheric release with silencer, with vacuum filter)

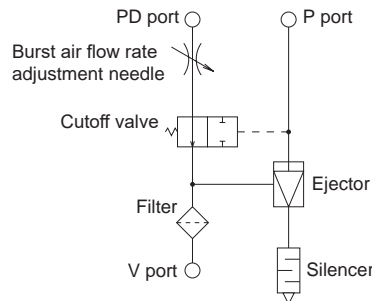

- VSY-*J (common exhaust)

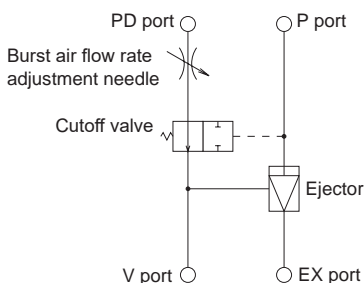

- VSY-*J-F (common exhaust, with vacuum filter)

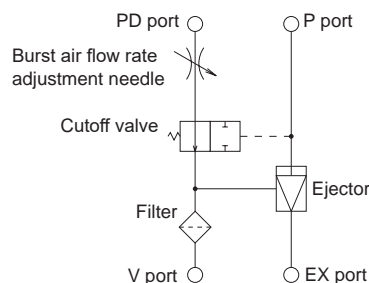

How to order

- Vacuum ejector with vacuum burst function

VSY - H 07 - 6 6 6 S - F

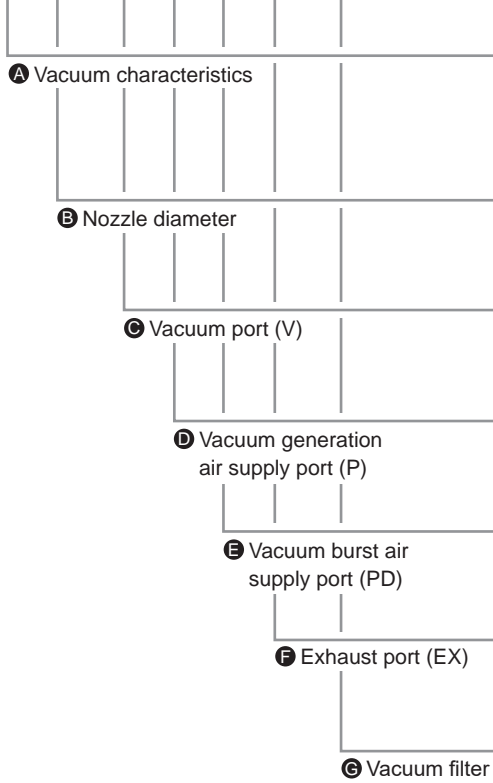

Code	Content
A Vacuum characteristics	
H	High vacuum/medium flow rate
L	Medium vacuum/large flow rate
E	High vacuum/low flow rate
B Nozzle diameter	
05	ø0.5
07	ø0.7
C Vacuum port (V) *1	
4	ø4 push-in fitting
6	ø6 push-in fitting
D Vacuum generation air supply port (P) *1	
4	ø4 push-in fitting
6	ø6 push-in fitting
E Vacuum burst air supply port (PD) *1	
4	ø4 push-in fitting
6	ø6 push-in fitting
F Exhaust port (EX)	
S	Atmospheric release with silencer
J	Common exhaust
G Vacuum filter	
Blank	None
F	With vacuum filter

Ejector system

VSY

VSHVSV
VSBVSC

VSG

VSK
VSKM

VSJ
VSJM

VSN
VSNM

VSX
VSXM

VSQ

VSZM

⚠ Precautions for model No. selection

- *1: Only 444 or 666 can be selected for the combination of **C**, **D** and **E**.

- Maintenance part model No.
- Replacement vacuum filter

VSY - F - 44M

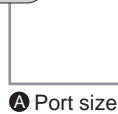

Code	Content
A Port size	
44M	For VSY-*444*
66M	For VSY-*666*

- Dedicated bracket

VSY - B

Vacuum characteristics, flow characteristics

● VSY-□05

Vacuum characteristics

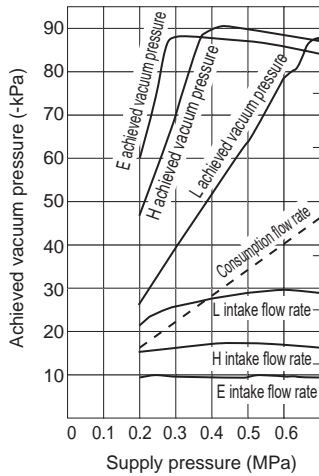

Flow characteristics

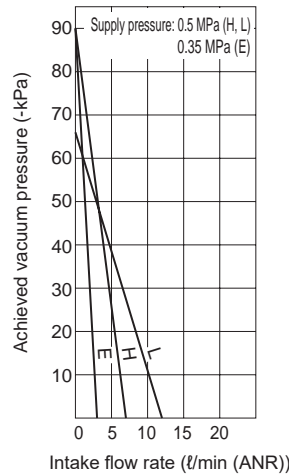

● VSY-□07

Vacuum characteristics

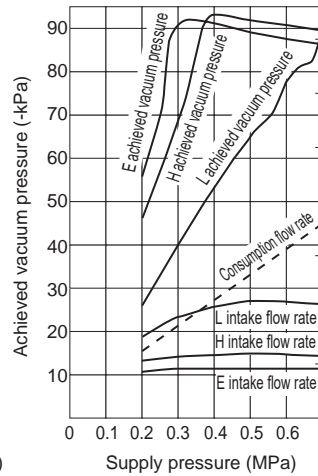

Flow characteristics

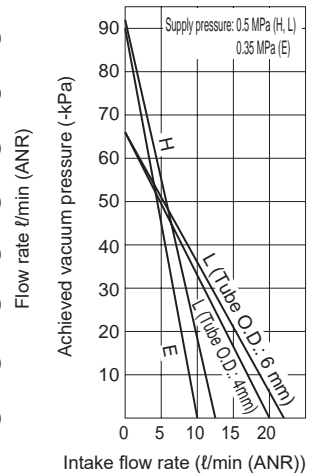

- Supply pressure with the characteristics described above occurs at vacuum generation.
- Achieved vacuum pressure with the characteristics described above produces abnormal noise (soft clicking sound) at supply pressure just before reaching the peak value. When this abnormal noise occurs, the characteristics become unstable and operation becomes louder. Reset the supply pressure, as it may affect the sensor, etc., and cause trouble.
 Ex. 1: Source pressure is 0.5 MPa with the H vacuum ejector. During vacuum ejector operation, supply pressure drops to 0.43 MPa due to pressure drop, and abnormal noise is generated. → Reset supply pressure to 0.5 MPa during vacuum ejector operation.
- Carry out piping or equipment selection with 3 times the effective cross-sectional area of the nozzle diameter cross-sectional area as a guideline. Satisfactory vacuum characteristics cannot be obtained if adequate supply air flow rate is not maintained.
 (A soft clicking sound occurs at set pressure. Insufficient intake flow rate, insufficient achievement of achieved vacuum pressure, etc.)
 Ex. 2: Abnormal noise occurs even when pressure is 0.5 MPa with H vacuum ejector during vacuum ejector operation. → Insufficient supply air flow rate. (Supply air flow rate is restricted in front of the vacuum ejector by piping resistance, etc., and supply air flow rate satisfying the properties is not obtained. → Select piping components that can secure the required effective cross-sectional area.)
 Ex. 3: For vacuum ejector with 0.7 mm nozzle diameter, cross-sectional area is $0.35^2 \times \pi = 0.785 \text{ mm}^2 \times 3 = 1.15 \text{ mm}^2$. Therefore, carry out piping and equipment selection that ensures an effective cross-sectional area of 1.1 mm² or greater.

Internal structure

● VSY

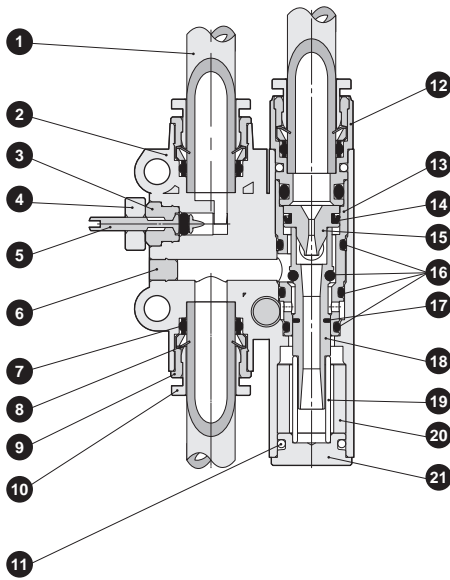

No.	Part name	Material
1	Tube	-
2	Resin body	PBT
3	Upper plug	Brass, electroless nickeling
4	Lock nut	Aluminum
5	Burst needle	SUS303 or equiv.
6	Plug 2	Brass, electroless nickeling
7	Elastic sleeve	NBR
8	Lock claw	Stainless steel
9	Guide ring	Brass, electroless nickeling
10	Release ring	POM
11	Spring pin	Stainless steel
12	Cartridge	-
13	Sleeve	Brass, electroless nickeling
14	Y packing	NBR
15	Nozzle piston	Brass, electroless nickeling
16	O-ring	NBR
17	Spool packing	H-NBR
18	Diffuser spool	Brass, electroless nickeling
19	Diffuser spring	Stainless steel
20	Silencer element	PVF
21	End plug	Brass, electroless nickeling

● Vacuum filter

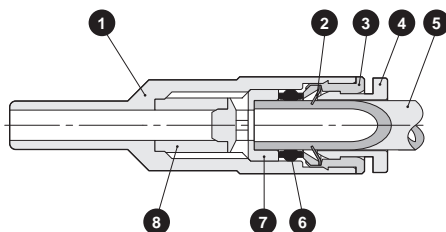

No.	Part name	Material
1	Resin body	PP
2	Lock claw	Stainless steel
3	Guide ring	Brass, electroless nickeling
4	Release ring	POM
5	Tube	Urethane or nylon
6	Elastic sleeve	NBR
7	Element holder	POM
8	Filter element	PVF

Dimensions

● VSY-*S (atmospheric release with silencer)

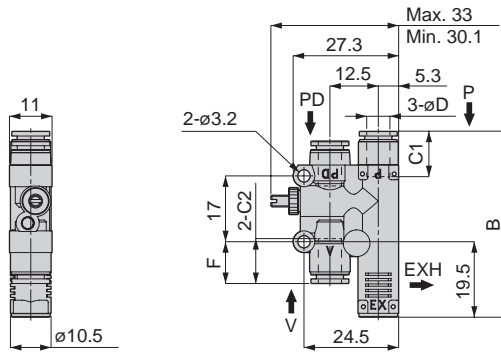

Ejector system

Model No.	Tube O.D. øD	B	F	C1	C2	Nozzle diameter	Rated pressure (MPa)	Achieved vac press (-kPa)	Intake flow rate (l/min(ANR))	Air consump rate (l/min(ANR))	Weight (g)			
VSY-H05-444S	4	45.4	10.7	11.2	11.3	0.5	0.5	90	7	11.5	19			
VSY-H05-666S	6	48.2	11	11.9	11.8							20		
VSY-H07-444S	4	45.4	10.7	11.2	11.3	0.7			92	12.5	23		20	
VSY-H07-666S	6	48.2	11	11.9	11.8							20		
VSY-L05-444S	4	45.4	10.7	11.2	11.3	0.5				66	12		11.5	19
VSY-L05-666S	6	48.2	11	11.9	11.8							20		
VSY-L07-444S	4	45.4	10.7	11.2	11.3	0.7		21			18		23	19
VSY-L07-666S	6	48.2	11	11.9	11.8							20		
VSY-E05-444S	4	45.4	10.7	11.2	11.3	0.5			0.35		90		3	8
VSY-E05-666S	6	48.2	11	11.9	11.8							20		
VSY-E07-444S	4	45.4	10.7	11.2	11.3	0.7				9			17	20
VSY-E07-666S	6	48.2	11	11.9	11.8							20		

VSY

VSHVSV
VSBVSC

VSG

● VSY-*S-F (atmospheric release with silencer, with vacuum filter)

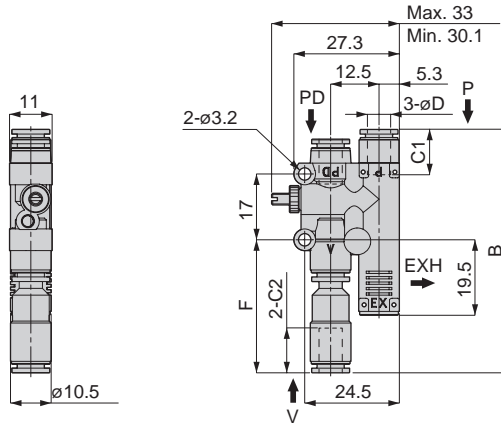

VSK
VSKM

VSJ
VSJM

VSN
VSNM

VSX
VSXM

VSQ

Model No.	Tube O.D. øD	B	F	C1	C2	Nozzle diameter	Rated pressure (MPa)	Achieved vac press (-kPa)	Intake flow rate (l/min(ANR))	Air consump rate (l/min(ANR))	Weight (g)			
VSY-H05-444S-F	4	60.3	34.4	11.2	11.3	0.5	0.5	90	7	11.5	21			
VSY-H05-666S-F	6	63.3	34.6	11.9	11.8							22		
VSY-H07-444S-F	4	60.3	34.4	11.2	11.3	0.7			92	12.5	23		21	
VSY-H07-666S-F	6	63.3	34.6	11.9	11.8							22		
VSY-L05-444S-F	4	60.3	34.4	11.2	11.3	0.5				66	12		11.5	21
VSY-L05-666S-F	6	63.3	34.6	11.9	11.8							22		
VSY-L07-444S-F	4	60.3	34.4	11.2	11.3	0.7		21			18		23	21
VSY-L07-666S-F	6	63.3	34.6	11.9	11.8							22		
VSY-E05-444S-F	4	60.3	34.4	11.2	11.3	0.5			0.35		90		3	8
VSY-E05-666S-F	6	63.3	34.6	11.9	11.8							22		
VSY-E07-444S-F	4	60.3	34.4	11.2	11.3	0.7				9			17	21
VSY-E07-666S-F	6	63.3	34.6	11.9	11.8							22		

VSZM

Dimensions

● VSY-*J (common exhaust)

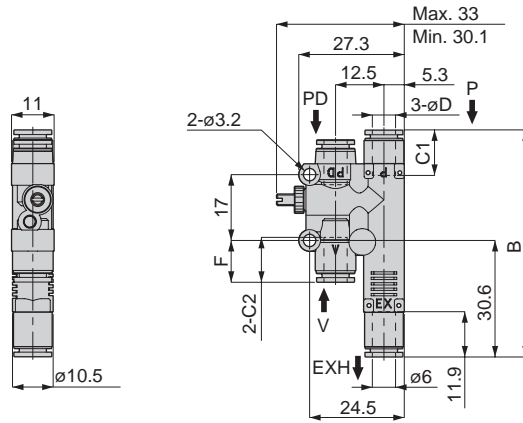

Model No.	Tube O.D. øD	B	F	C1	C2	Nozzle diameter	Rated pressure (MPa)	Achieved vac press (-kPa)	Intake flow rate (l/min(ANR))	Air consump rate (l/min(ANR))	Weight (g)
VSY-H05-444J	4	56.3	10.7	11.2	11.3	0.5	0.5	90	7	11.5	23
VSY-H05-666J	6	59	11	11.9	11.8						
VSY-H07-444J	4	56.3	10.7	11.2	11.3	0.7		92	12.5	23	23
VSY-H07-666J	6	59	11	11.9	11.8						
VSY-L05-444J	4	56.3	10.7	11.2	11.3	0.5		66	12	11.5	23
VSY-L05-666J	6	59	11	11.9	11.8						
VSY-L07-444J	4	56.3	10.7	11.2	11.3	0.7	18		23	23	
VSY-L07-666J	6	59	11	11.9	11.8						
VSY-E05-444J	4	56.3	10.7	11.2	11.3	0.5	90	3	8	23	
VSY-E05-666J	6	59	11	11.9	11.8						
VSY-E07-444J	4	56.3	10.7	11.2	11.3	0.7		9	17	24	
VSY-E07-666J	6	59	11	11.9	11.8						

● VSY-*J-F (common exhaust, with vacuum filter)

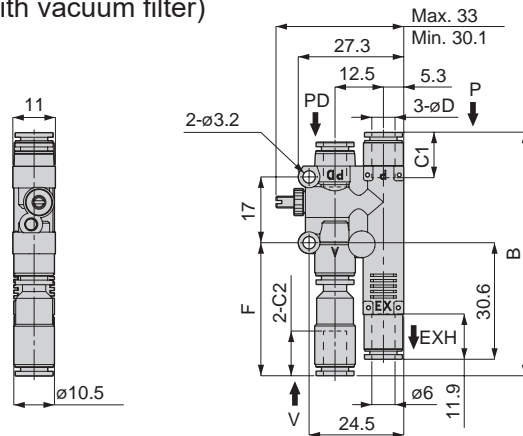

Model No.	Tube O.D. øD	B	F	C1	C2	Nozzle diameter	Rated pressure (MPa)	Achieved vac press (-kPa)	Intake flow rate (l/min(ANR))	Air consump rate (l/min(ANR))	Weight (g)
VSY-H05-444J-F	4	60.3	34.4	11.2	11.3	0.5	0.5	90	7	11.5	24
VSY-H05-666J-F	6	63.3	34.6	11.9	11.8						
VSY-H07-444J-F	4	60.3	34.4	11.2	11.3	0.7		92	12.5	23	25
VSY-H07-666J-F	6	63.3	34.6	11.9	11.8						
VSY-L05-444J-F	4	60.3	34.4	11.2	11.3	0.5		66	12	11.5	24
VSY-L05-666J-F	6	63.3	34.6	11.9	11.8						
VSY-L07-444J-F	4	60.3	34.4	11.2	11.3	0.7	18		23	24	
VSY-L07-666J-F	6	63.3	34.6	11.9	11.8						
VSY-E05-444J-F	4	60.3	34.4	11.2	11.3	0.5	90	3	8	24	
VSY-E05-666J-F	6	63.3	34.6	11.9	11.8						
VSY-E07-444J-F	4	60.3	34.4	11.2	11.3	0.7		9	17	25	
VSY-E07-666J-F	6	63.3	34.6	11.9	11.8						

Dimensions

● VSY-F (replacement vacuum filter)

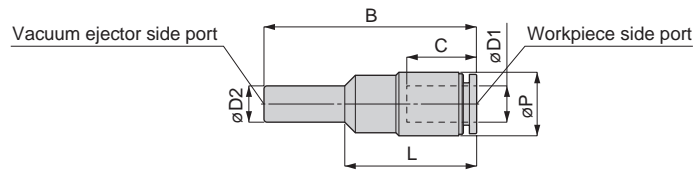

Model No.	Tube O.D. øD1	Fitting diameter øD2	B	L	C	øP	Filtration area (cm ²)	Weight (g)
VSY-F-44M	4	4	35	21.8	11.3	8	0.8	1.5
VSY-F-66M	6	6	35.4	22	11.8	10.5	1.1	2.5

● VSY-B (bracket)

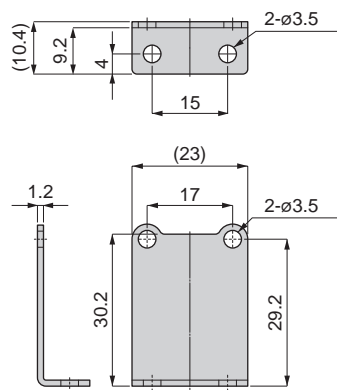

Ejector system

VSY

VSHVSV
VSBVSC

VSG

VSK
VSKM

VSJ
VSJM

VSN
VSNM

VSX
VSXM

VSQ

VSZM

Safety precautions

Refer to Intro Pages 15 and 16 for general precautions on vacuum system components.

⚠ WARNING

■ Read the catalog carefully regarding the piping method of VSY vacuum ejector. Errors in the piping method may cause injury or component damage.

■ Since the filter body material is PP, the resin may deteriorate due to direct sunlight or ultraviolet rays.

⚠ CAUTION

■ Read the catalog carefully regarding flow rate adjustment and burst time adjustment for burst air.

■ The built-in vacuum filter cannot be replaced by a single element. For replacement during maintenance inspections, etc., the filter body should be replaced.

■ When using different pressures for supply air for vacuum generation and vacuum burst, be sure to set the pressure for vacuum burst lower than that of vacuum generation.

If set higher than the supply air pressure for vacuum generation, it may lead to leakage.

■ When using the following piping method, burst air may enter instantaneously from the check valve and be emitted from the V port until the shut-off valve completes switching.

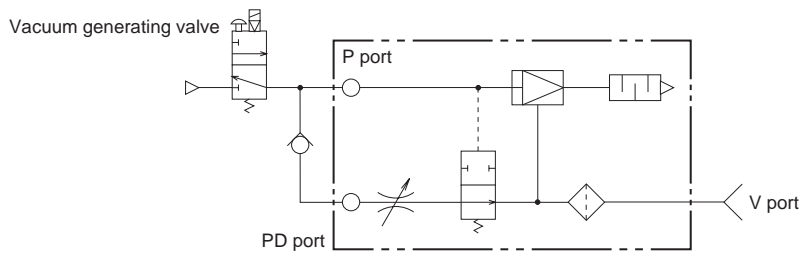

Ejector system

VSY

VSH/VSU
VSB/VSC

VSG

VSK
VSKM

VSJ
VSJM

VSN
VSNM

VSX
VSXM

VSQ

VSZM

Usage methods

[Example 1]

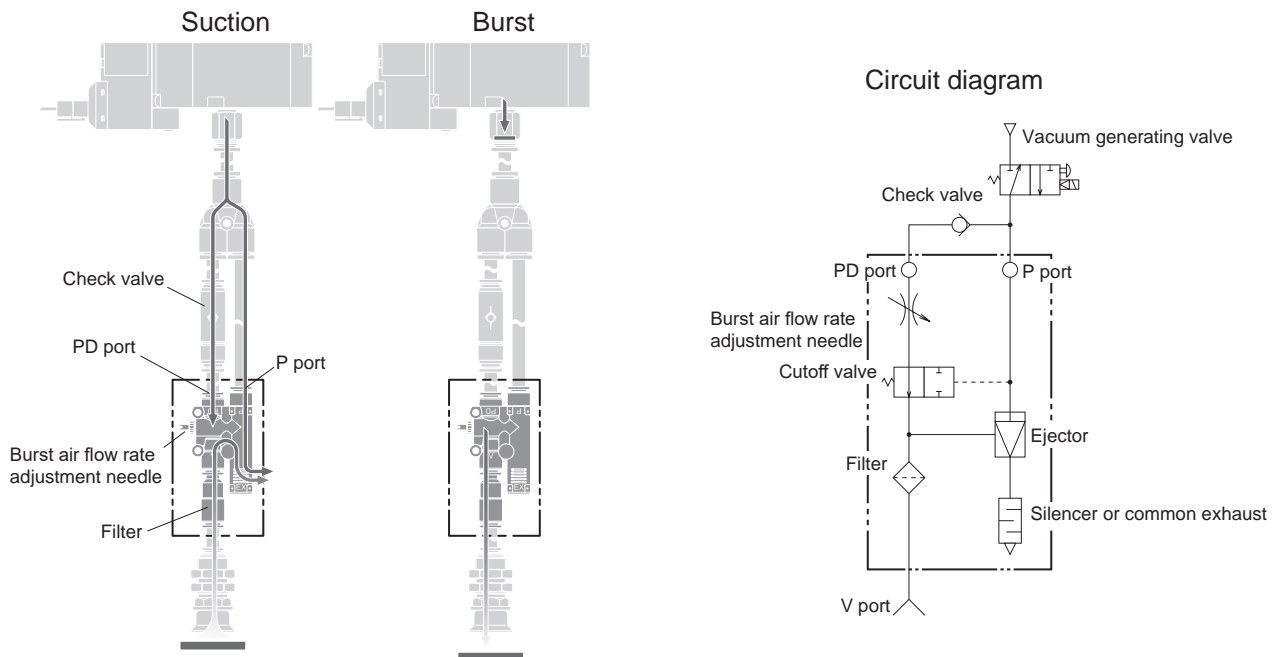

Connect the P port and PD port with a check valve (separately purchased) and use the residual pressure between the check valve and the PD port as burst air.

The burst air flow rate can be adjusted with the burst air flow adjustment needle, and the burst time can be adjusted with the length of the tube connecting the check valve and PD port.

[Example 2]

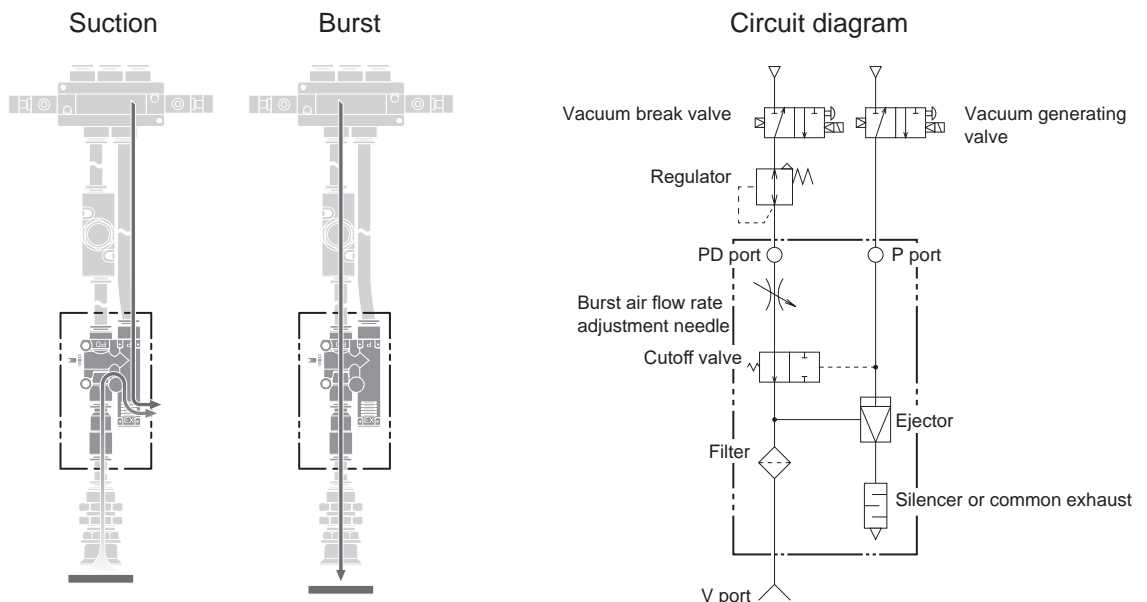

When instantaneously removing a workpiece with vacuum burst air, adjust the burst air pressure and flow rate, but be careful not to blow off the workpiece. The figure above is an example of using different pressures for the supply air for vacuum generation and vacuum burst, such as when lowering the air pressure for vacuum burst. (Note: supply pressure for vacuum generation \geq supply pressure for vacuum burst.)

Adjust the flow rate of the vacuum burst air with the burst air flow adjustment needle, and control the burst time by controlling the vacuum burst valve or the like.

Ejector system

VS_Y

VSH/VSU
VSB/VSC

VSG

VSK
VSKM

VSJ
VSJM

VSN
VSNM

VSX
VSXM

VSQ

VSZM