

Discontinue
 FSM2-D Series in on sale.
 Please refer to FSM3 Series.

Small size flow rate sensor/RAPIFLOW **FSM2 Series**

Line-up to match your every need.

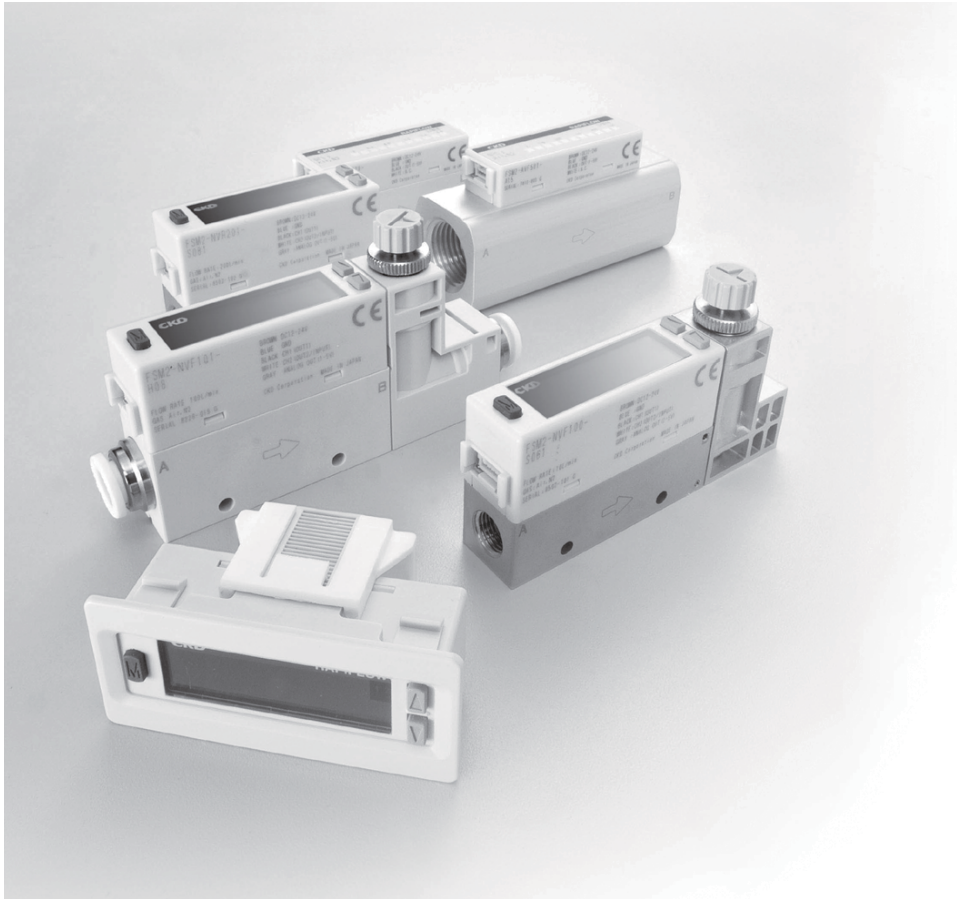

Needle valve integrated

The needle valve, which can adjust the flow rate, has been integrated with the sensor to simplify piping and realize space saving.

Stainless steel bodies also available



Stainless steel body



Resin body

Separated display

When connected to a sensor, the separate display automatically recognizes the flow rate range, so settings with the indicator are not required.* Complete wiring easily with the connector method.

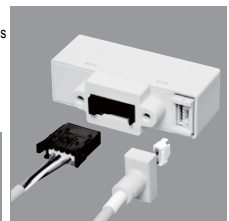

*Only in the default state or when settings are reset. Refer to "Explanation of functions" on page 1032 for details.

- SCPD3
- SCM
- MDC2
- SMG
- SSD2
- STM
- STG
- LCR
- LCG
- LCX
- LCM
- STR2
- MRL2
- GRC
- Cylinder switch
- MN3E
MN4E
- 4GA/B
- M4GA/B
- MN4GA/B
- F.R. (module unit)
- Clean F.R.
- Precision R
- Press gauge
Diff. press gauge
- Electro-pneumatic R
- Speed controller
- Auxiliary valve
- Fitting/tube
- Clean air unit
- Pressure sensor
- Flow rate sensor
- Valve for air blow
- Ending

Discontinue

Functions which pursue the operability of the small size flow rate sensor
Provide the best selections for various scenes and applications.

Clean room specifications (P70, P80)

The P70 (dust generation preventing) and P80 (oil-prohibited specifications) are available as a standard. These models are perfect for semiconductor and liquid crystal display manufacturing applications.

Panel mounting

A panel mounting bracket is available. The separate display, sensor unit (up to display integrated 200 L/min type), and needle valve integrated can be mounted onto a panel.

Close mounting with one panel opening is possible, allowing man-hours and space to be reduced when using multiple units.

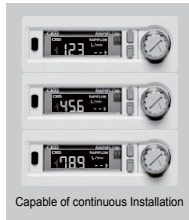

Twin display/2-color display function

A main screen and sub screen can be provided with the display integrated, allowing operability to be improved. The errors can be seen in a glance with the 2-color display.

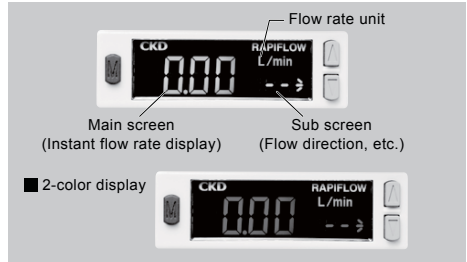

Bar display function

On the separate display type, the reference flow rate can be seen in a glance with the flow rate bar display.



Compact even with large flow rate

With 500 and 1000 L/min types, the body size has been reduced by 30% compared to conventional models, attaining the highest downsizing in the industry. Helps to create a compact and light system.

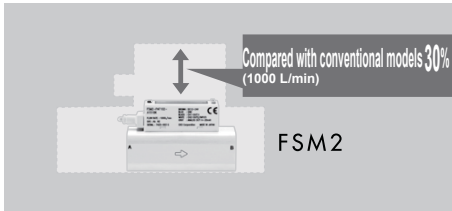

Improvement of accuracy $\pm 3\%$ F.S. or less

An accuracy of $\pm 3\%$ F.S. allows a more accurate flow rate measurement.

High speed response 50msec or less

The platinum sensor chip manufactured with silicone micromachining realizes a high speed response, and contributes to reducing the tact time.

Free mounting position

The sensor can be mounted in any direction, top, bottom, left or right.



Straight piping section not required

The newly proposed rectifying mechanism eliminates the need for straight piping at either the upstream or downstream side.



Elbow OK

CKD



SCPD3
SCM
MDC2
SMG
SSD2
STM
STG
LCR
LCG
LCX
LCM
STR2
MRL2
GRC
Cylinder switch
MN3E MN4E
4GA/B
M4GA/B
MN4GA/B
F.R.(module unit)
Clean F.R.
Precision R
Press.gauge Diff.press.gauge
Electro-pneumatic R
Speed controller
Auxiliary valve
Fitting/tube
Clean air unit
Pressure sensor
Flow rate sensor
Valve for air blow
Ending

Diverse line-up to match your needs

Discontinue

SCPD3
SCM
MDC2
SMG
SSD2
STM
STG
LCR
LCG
LCX
LCM
STR2
MRL2
GRC
Cylinder switch
MN3E/MN4E
4GA/B
M4GA/B
MN4GA/B
F.R. (module unit)
Clean F.R.
Precision R
Press gauge
Diff. press gauge
Electro-pneumatic R
Speed controller
Auxiliary valve
Fitting/tube
Clean air unit
Pressure sensor
Flow rate sensor
Valve for air blow
Ending

Flow rate range/port size/body material



Body material	Port size	Full scale flow rate											
		500 ml/min	1 l/min	2 l/min	5 l/min	10 l/min	20 l/min	50 l/min	100 l/min	200 l/min	500 l/min	1,000 l/min	
Resin 	ø 4 push-in	●	●	●	●	●	●						
	ø 6 push-in	●	●	●	●	●	●	●					
	ø 8 push-in							●	●	●			
	ø 10 push-in								●	●			
Stainless steel 	Rc1/8	●	●	●	●	●	●	● Note 1					
	Rc1/4							●	●	● Note 2			
	M5	●	●	●	●	●	● Note 1						
Aluminum 	Rc1/2										●	●	

Note 1: Excluding carbon dioxide models Note 2: Excluding argon models and carbon dioxide models

Applicable fluids

Applicable fluids	Body material	Full scale flow rate											
		500 ml/min	1 l/min	2 l/min	5 l/min	10 l/min	20 l/min	50 l/min	100 l/min	200 l/min	500 l/min	1,000 l/min	
Air/nitrogen	Resin	●	●	●	●	●	●	●	●	●			
	Stainless steel	●	●	●	●	●	●	●	●	●			
	Aluminum										●	●	
Argon	Stainless steel	●	●	●	●	●	●	●	●	●			
Carbon dioxide (CO ₂)	Stainless steel	●	●	●	●	●	●	●	●	●			

Output type

Type	Output
Display integrated 	Analog output 1 point (1 to 5 V or 4 to 20 mA) Switch output 2 points (NPN or PNP)
Display separated 	Analog output 1 point (1 to 5 V or 4 to 20 mA) Capable of connecting separate display



Needle valve integrated (option)

Supporting up to full scale 200 l/min (only for display integrated)

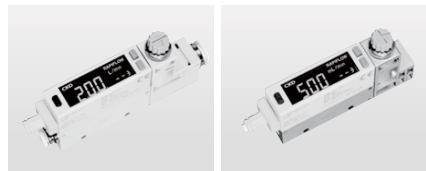
- Resin body
- Stainless steel body



Flow direction

Bi-direction	Uni-direction
	
Flow direction can be selected with button operations (Display integrated)	

Clean room specifications (option)

- P70 specifications: Countermeasures for dust generation
- P80 specifications: Oil-prohibited

Air consumption flow rate control

The air consumed of an individual facility can be seen by monitoring the integration pulse output or analog output.

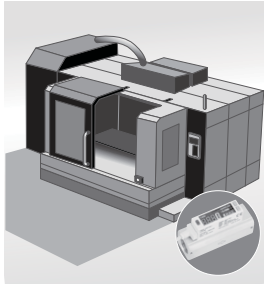
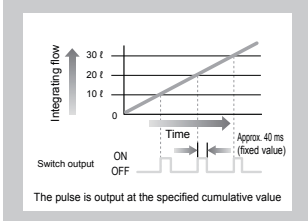

Painting air flow rate control

P80 (oil-prohibited specifications) are perfect for controlling the flow rate of painting air. FSM2 is free of siloxane (organic silicone), so the paint quality is stable.

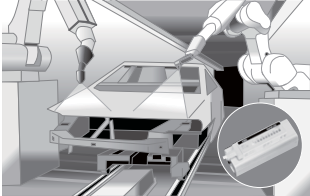

Semiconductor manufacturing system purge gas flow rate control

Control of the purge gas is indispensable for maintaining the performance of a semiconductor manufacturing system. The stainless steel body is suitable for applications which are susceptible to discharged gases. Errors can be detected with the switch output.

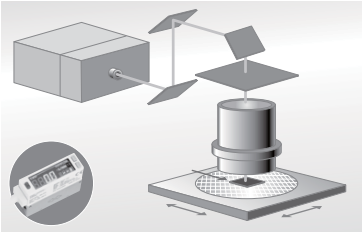
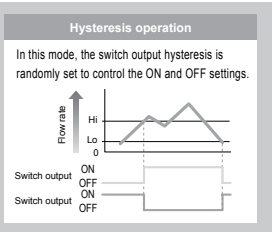
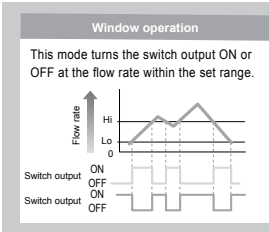

Ionizer flow rate control

The flow rate can be easily adjusted with the needle valve integrated. The P80 (oil-prohibited specifications) are suitable for clean applications. Errors can be detected with the switch output.

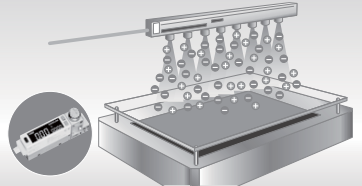

Suction confirmation

Since the flow rate is detected, there's no need to make adjustments caused by pressure fluctuations and incorrect detections are eliminated. Capable of managing detection of a clogged nozzle or filter and of a suction failure such as oblique suction.

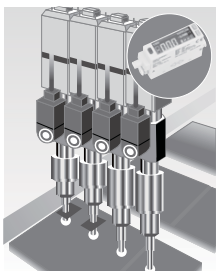
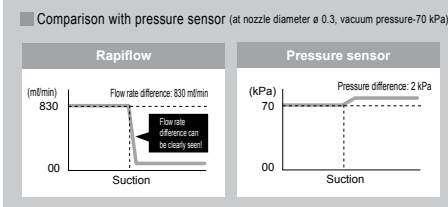

SCPD3
SCM
MDC2
SMG
SSD2
STM
STG
LCR
LCG
LCX
LCM
STR2
MRL2
GRC
Cylinder switch
MN3E MN4E
4GA/B
M4GA/B
MN4GA/B
F.R.(module unit)
Clean F.R.
Precision R
Press.gauge Diff.press.gauge
Electro-pneumatic R
Speed controller
Auxiliary valve
Fitting/tube
Clean air unit
Pressure sensor
Flow rate sensor
Valve for air blow
Ending

Discontinue

Small size flow rate sensor RA1FLOW
Display integrated/display separated

FSM2 Series

- Resin body (flow rate range: 500 ml/min to 200 l/min)
- Aluminum body (flow rate range: 500 l/min, 1000 l/min)
- Stainless steel body (flow rate range: 500 ml/min to 200 l/min)



Display integrated (resin/aluminum body) specifications

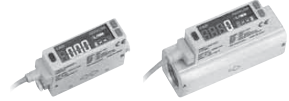

Descriptions		Display integrated (resin/aluminum body)													
		FSM2 - (*1) (*2) (*3) (*4) - (*5) (*6) - (*7)													
		Full scale flow rate	005	010	020	050	100	200	500	101	201	501	102		
Flow rate range *1	*4	005	500 ml/min	●											
		010	1 l/min		●										
		020	2 l/min			●									
		050	5 l/min				●								
		100	10 l/min					●							
		200	20 l/min						●						
		500	50 l/min							●					
		101	100 l/min								●				
		201	200 l/min									●			
		501	500 l/min										●		
		102	1000 l/min											●	
		Port size/body material	*5	H04	ø 4 Push-in/resin	●	●	●	●	●	●	●			
H06	ø 6 Push-in/resin			●	●	●	●	●	●	●					
H08	ø 8 Push-in/resin										●	●			
H10	ø 10 Push-in/resin											●	●		
A15	Rc1/2/aluminum												●	●	
Needle valve integrated	*1	*6	N	●	●	●	●	●	●	●	●	●			
Flow rate display	*2, *3	Type of display		4 digit + 4 digit 2-color LCD											
		Display range	*3	F	0 to 500 ml/min	0 to 1000 ml/min	0 to 2.00 l/min	0 to 5.00 l/min	0 to 10.00 l/min	0 to 20.0 l/min	0 to 50.0 l/min	0 to 100.0 l/min	0 to 200 l/min	0 to 500 l/min	0 to 1000 l/min
				R	-500 to 500 ml/min	-1000 to 1000 ml/min	-2.00 to 2.00 l/min	-5.00 to 5.00 l/min	-10.00 to 10.00 l/min	-20.0 to 20.0 l/min	-50.0 to 50.0 l/min	-100.0 to 100.0 l/min	-200 to 200 l/min	-500 to 500 l/min	-1000 to 1000 l/min
Display resolution		1 ml/min			0.01 l/min			0.1 l/min			1 l/min				
Integrating functions		Display range		9999999 mt			99999.99 t			999999.9 t			9999999 t		
		Display resolution		1 ml			0.01 t			0.1 t			1 t		
Integrating pulse output rate		*6		5 mt	10 mt	0.02 t	0.05 t	0.1 t	0.2 t	0.5 t	1 t	2 t	5 t	10 t	
Working conditions	Applicable fluid		*5 Clean air (JIS B 8392-1:2012 (ISO 8573-1:2010) [1:1.1 to 5:6.2]), compressed air (JIS B 8392-1:2012 (ISO 8573-1:2010) [1:1.1 to 1:6.2]), nitrogen gas												
	Max. working pressure		0.7 MPa (=100 psi, 7 bar)												
	Min. working pressure		-0.09 MPa (= -13.05 psi, -0.9 bar)												
	Proof pressure		1.0 MPa (=150 psi, 10 bar)												
	Operating ambient temperature/humidity		0°C (32°F) to 50°C (122°F), 90%RH or less												
Accuracy	Fluid temperature		0°C (32°F) to 50°C (122°F) (no dew condensation)												
	Specified range		Uni-direction: 3 to 100% F.S., bi-direction: -100 to -3% F.S., 3 to 100% F.S.												
	Linearity (display/analog output)		Within ±3% F.S. (Secondary side released to atmosphere)												
	Pressure characteristics		Within ±5% F.S. (-0.09 to 0.7 MPa, where secondary side is released to atmosphere)												
	Temperature characteristics		Within ±0.2% F.S./°C (15 to 35°C, 25°C reference)												
*6		Reproducibility (repeatability)		Within ±1% F.S.											
*7		Response time		50 ms or less											
Output	Switch output	*1	N	Output 2 points (NPN open collector output, 50 mA or less, voltage drop 2.4 V or less)											
			P	Output 2 points (PNP open collector output, 50 mA or less, voltage drop 2.4 V or less)											
		Analog output	*2	V	1 to 5 V voltage output 1 point (connecting load impedance 50 kΩ and over) *8										
A	4 to 20 mA current output 1 point (connecting load impedance 0 to 300 Ω)														
Power supply voltage *9		*2	V	12 to 24 VDC (10.8 to 26.4 V)											
			A	24 VDC (21.6 to 26.4 V)											
Current consumption		*10		50 mA or less											
Cable		ø 3.7, AWG26 or equivalent × 5-conductor (connector connection), insulator outer diameter ø 1.0													
Holding function		Flow rate display, flow rate display peak hold, switch output, analog output, etc.													
Installation	Mounting orientation		Unrestricted in vertical/horizontal direction												
	Straight piping section		Not required												
Degree of protection		IEC standards IP40 or equivalent													
*11		Protection circuit		Power reverse connection protection, switch output reverse connection protection, switch output load short-circuit protection											
EMC Directive		EN55011, EN61000-6-2, EN61000-4-2/3/4/6/8													
Weight (main body only)	*5	H04	Approx. 50 g (approx. 80 g with needle valve)												
		H06	Approx. 50 g (approx. 80 g with needle valve)												
		H08	Approx. 70 g (approx. 110 g with needle valve)												
		H10	Approx. 75 g (approx. 115 g with needle valve)												
		A15	Approx. 155 g												
Clean room specifications		*7	P70	Dust generation preventing *12											
			P80	Oil-prohibited *13											

Discontinue

FSM2 Series Specifications



Display integrated (stainless steel body) specifications

Descriptions		Display integrated (stainless steel body)										
		FSM2 - (*1) (*2) (*3) (*4) - (*5) (*6) (*7) - (*8)										
Flow rate range *1	*4	005	500 ml/min	●								
		010	1 l/min		●							
		020	2 l/min			●						
		050	5 l/min				●					
		100	10 l/min					●				
		200	20 l/min						●			
		500	50 l/min							●		
		101	100 l/min								●	
Port size/ Body material	*5	S06	Rc1/8 stainless steel	●	●	●	●	●	●	●	●	
		S08	Rc1/4 stainless steel								●	
		SM5	M5 stainless steel (custom order product)	●	●	●	●	●	●	●	●	
Needle valve integrated	*1	*7	N	●	●	●	●	●	●	●		
Flow rate display *2, *3	*3	Type of display		4 digit + 4 digit 2-color LCD								
		Display range	F	0 to 500 ml/min	0 to 1000 ml/min	0 to 2.00 l/min	0 to 5.00 l/min	0 to 10.00 l/min	0 to 20.0 l/min	0 to 50.0 l/min	0 to 100.0 l/min	0 to 200 l/min
			R	-500 to 500 ml/min	-1000 to 1000 ml/min	-2.00 to 2.00 l/min	-5.00 to 5.00 l/min	-10.00 to 10.00 l/min	-20.0 to 20.0 l/min	-50.0 to 50.0 l/min	-100.0 to 100.0 l/min	-200 to 200 l/min
		Display resolution		1 ml/min			0.01 l/min			0.1 l/min		1 l/min
Integrating functions *4	Display range		9999999 ml			99999.99 l			999999.9 l		9999999 l	
	Display resolution		1 ml			0.01 l			0.1 l		1 l	
	Integrated pulse output rate		5 mt		10 mt		0.02 l		0.05 l		0.1 l	
Working conditions *5	*6	Applicable fluid	Blank	Clean air (JIS B 8392-1:2012 (ISO 8573-1:2010) (1:1 to 5:6:2)), compressed air (JIS B 8392-1:2012 (ISO 8573-1:2010) (1:1 to 1:6:2)), nitrogen gas								
			AR	Argon								
			C2	Carbon dioxide (CO ₂)								
		Max. working pressure	1.0 MPa (≈150 psi, 10 bar)									
		Min. working pressure	-0.09 MPa (≈-13.05 psi, -0.9 bar)									
Accuracy *6	*7	Proof pressure	1.5 MPa (≈217 psi, 15 bar)									
		Operating ambient temperature/humidity	0°C (32°F) to 50°C (122°F), 90%RH or less									
		Fluid temperature	0°C (32°F) to 50°C (122°F) (no dew condensation)									
		Specified range	Uni-direction: 3 to 100% F.S., bi-direction type: -100 to -3% F.S., 3 to 100% F.S.									
		Linearity (display/analog output)	Within ±3% F.S. (Secondary side released to atmosphere)									
Response time	*1	Switch output	N	Output 2 points (NPN open collector output, 50 mA or less, voltage drop 2.4 V or less)								
			P	Output 2 points (PNP open collector output, 50 mA or less, voltage drop 2.4 V or less)								
			V	1 to 5 V voltage output 1 point (connecting load impedance 50 kΩ and over) *8								
Output	*2	Analogue output	A	4 to 20 mA current output 1 point (connecting load impedance 0 to 300 Ω)								
			V	12 to 24 VDC (10.8 to 26.4 V)								
Power supply voltage	*9	A	24 VDC (21.6 to 26.4 V)									
Current consumption	*10	50 mA or less										
Cable	ø 3.7, AWG26 or equivalent × 5-conductor (connector connection), insulator outer diameter ø 1.0											
Holding function	Flow rate display, flow rate display peak hold, switch output, analog output, etc.											
Installation	*11	Mounting orientation	Unrestricted in vertical/horizontal direction									
		Straight piping section	Not required									
Degree of protection	IEC standards IP40 or equivalent											
Protection circuit	Power reverse connection protection, switch output reverse connection protection, switch output load short-circuit protection											
EMC Directive	EN55011, EN61000-6-2, EN61000-4-2/3/4/6/8											
Weight (main body only)	*5	S06	Approx. 95 g (approx. 160 g with needle valve)									
		S08	Approx. 115 g (approx. 200 g with needle valve)									
		SM5	Approx. 140 g									
Clean room specifications	*8	P70	Dust generation preventing *12									
		P80	Oil-prohibited *13									

*1: This valve cannot be used as a stop valve that has no leakage. Slight leakage is allowed in specifications.

*2: The value converted to volumetric flow rate at standard condition (20°C, 1 barometric pressure (101 kPa) relative humidity 65%)

*3: The flow rate display is rounded off at approx. ±1% F.S. or less (forced zero).

*4: The integrating flow is a calculated (reference) value. It will be reset when the power is turned OFF.

*5: Use dry gas which does not contain corrosive elements such as chlorine, sulphur or acids, and which is clean and does not contain dust or oil mist. When using compressed air, use clean air that complies to JIS B 8392-1: 2012 Class 1, 1-1 to 1.6.2. Compressed air from the compressor contains drainage-water, oxide, foreign substances, etc. To maintain the function of this product, install a filter, air dryer (min. pressure dew point 10°C or less), and oil mist filter (max. oil concentration 0.1 mg/m³) on the primary side (upper stream side) of this product.

[Recommended circuit]

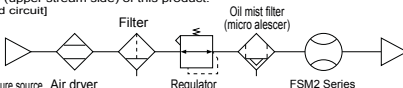

[Recommended device]

Air filter: F Series

Oil mist filter: M Series

*6: Calibration of this product is performed within specified range. Accuracy conditions: Temperature 25±3°C, power supply voltage 24±0.01 VDC. F.S. stands for full scale flow rate.

*7: Response time can be set in seven steps from 50 ms. or less to approx. 1.5 s.

*8: The output impedance of the analog output section is approx. 1 kΩ. If the impedance of the connecting load is small, error in output increase. Check error with the impedance of the connecting load before using.

*9: The power supply voltage specifications differ for the voltage output type and current output type.

*10: Current for when 24 VDC is connected, and no load is connected. The current consumption will vary depending on how the load is connected.

*11: This product's protection circuit is effective only for specific misconnections and load short-circuits. It does not provide protection for all misconnections.

*12: [P70] Dust generation preventing (product surface is degreased and cleaned before packing. Heat sealed into anti-static bag in clean bench (Class 1000 and over).)

*13: [P80] Oil-prohibited (in addition to P70 specifications, wetted sections are degreased and cleaned. Refer to the "Internal structure drawing and parts list" for details on the wetted section members.)

Display separated (resin/aluminum body) specifications



Descriptions		Display separated type (resin/aluminum body) FSM2 - A (*1) (*2) (*3) - (*4) - (*5)											
Full scale flow rate		005	010	020	050	100	200	500	101	201	501	102	
Flow rate range *1	*3	005	●										
		010		●									
		020			●								
		050				●							
		100					●						
		200						●					
		500							●				
		101								●			
		201									●		
		501										●	
102											●		
Port size/body material	*4	H04	●	●	●	●	●	●					
		H06	●	●	●	●	●	●					
		H08							●	●			
		H10								●	●		
		A15										●	●
Flow direction		*2	F	Uni-direction									
			R	Bi-direction									
Working conditions	Applicable fluid		*2 Clean air (JIS B 8392-1:2012 (ISO 8573-1:2010) [1:1:1 to 5:6:2]), compressed air (JIS B 8392-1:2012 (ISO 8573-1:2010) [1:1:1 to 1:6:2]), nitrogen gas										
	Max. working pressure		0.7 MPa (≈100 psi, 7 bar)										
	Min. working pressure		-0.09 MPa (≈-13.05 psi, -0.9 bar)										
	Proof pressure		1.0 MPa (≈150 psi, 10 bar)										
	Operating ambient temperature/humidity		0°C (32°F) to 50°C (122°F), 90%RH or less										
Accuracy	Fluid temperature		0°C (32°F) to 50°C (122°F) (no dew condensation)										
	Specified range		Uni-direction type: 3 to 100% F.S., bi-direction type: -100 to -3% F.S., 3 to 100% F.S.										
	Linearity (analog output)		Within ±3% F.S. (Secondary side released to atmosphere)										
	Pressure characteristics		Within ±5% F.S. (-0.09 (≈13 psi) to 0.7 MPa (≈0 psi), where secondary side is released to atmosphere)										
	Temperature characteristics		Within ±0.2% F.S./°C (15 (59°F) to 35°C (95°F), 25°C (77°F) reference)										
*3 Reproducibility (repeatability)		Within ±1% F.S.											
Response time		50 ms or less											
Type of display		Flow bar display											
Output	Analog output	*1	V	1 to 5 V voltage output 1 point (connecting load impedance 50 kΩ and over) *4									
			A	4 to 20 mA current output 1 point (connecting load impedance 0 to 300 Ω)									
Power supply voltage *5		*1	V	12 to 24 VDC (10.8 to 26.4 V)									
			A	24 VDC (21.6 to 26.4 V)									
Current consumption		*6 50 mA or less											
Cable		*6 ø 3.7, AWG26 or equivalent × 4-conductor (connector connection), insulator outer diameter ø 1.0											
Holding function		Analog output, flow bar display, error display											
Installation	Mounting orientation		Unrestricted in vertical/horizontal direction										
	Straight piping section		Not required										
Degree of protection		IEC standards IP40 or equivalent											
Protection circuit		*7 Power supply reverse connection protection											
EMC Directive		EN55011, EN61000-6-2, EN61000-4-2/3/4/6/8											
Weight (main body only)	*4	H04	Approx. 40 g										
		H06	Approx. 40 g										
		H08	Approx. 60 g										
		H10	Approx. 65 g										
		A15	Approx. 145 g										
Clean room specifications		*5	P70	Dust generation preventing *8									
			P80	Oil-prohibited *9									



Display separated (stainless steel body) specifications

Descriptions		Display separated (stainless steel body) FSM2 - A (*1) (*2) (*3) - (*4) (*5) - (*6)									
		Full scale flow rate	005	010	020	050	100	200	500	101	201
Flow rate range *1	*3	005	500 ml/min	●							
		010	1 l/min		●						
		020	2 l/min			●					
		050	5 l/min				●				
		100	10 l/min					●			
		200	20 l/min						●		
		500	50 l/min							●	
		101	100 l/min								●
Port size/ body material	*4	S06	Rc1/8 stainless steel	●	●	●	●	●	●		
		S08	Rc1/4 stainless steel							●	●
		SM5	M5 stainless steel (custom order product)	●	●	●	●	●	●		●
Flow direction		*2	F R	Uni-direction Bi-direction							
Applicable fluid *2	*5	Blank	Clean air (JIS B 8392-1:2012 (ISO 8573-1:2010) [1:1 to 5:6:2]), compressed air (JIS B 8392-1:2012 (ISO 8573-1:2010) [1:1 to 1:6:2]), nitrogen gas								
		AR C2	Argon Carbon dioxide (CO ₂)								
Max. working pressure		1.0 MPa (≈150 psi, 10 bar)									
Min. working pressure		-0.09 MPa (≈-13.05 psi, -0.9 bar)									
Proof pressure		1.5 MPa (≈217 psi, 15 bar)									
Operating ambient temperature/humidity		0°C (32°F) to 50°C (122°F), 90%RH or less									
Fluid temperature		0°C (32°F) to 50°C (122°F) (no dew condensation)									
Specified range		Uni-direction: 3 to 100% F.S., bi-direction: -100 to -3% F.S., 3 to 100% F.S.									
Linearity (analog output)		Within ±3% F.S. (Secondary side released to atmosphere)									
Pressure characteristics		Within ±5% F.S. (-0.09 (≈13 psi) to 0.7 MPa (≈100 psi), where secondary side is released to atmosphere)									
Temperature characteristics		Within ±0.2% F.S./°C (15 (59°F) to 35°C (95°F), 25°C (77°F) reference)									
*3 Reproducibility (repeatability)		Within ±1% F.S.									
Response time		50 ms or less									
Type of display		Flow bar display									
Output	Analog output	*1	V	1 to 5 V voltage output 1 point (connecting load impedance 50 kΩ and over) *4							
			A	4 to 20 mA current output 1 point (connecting load impedance 0 to 300 Ω)							
Power supply voltage	*5	*1	V	12 to 24 VDC (10.8 to 26.4 V)							
			A	24 VDC (21.6 to 26.4 V)							
Current consumption		*6		50 mA or less							
Cable		ø 3.7, AWG26 or equivalent × 4-conductor (connector connection), insulator outer diameter ø 1.0									
Holding function		Analog output, flow bar display, error display									
Installation	Mounting orientation		Unrestricted in vertical/horizontal direction								
	Straight piping section		Not required								
Degree of protection		IEC standards IP40 or equivalent									
Protection circuit		*7		Power supply reverse connection protection							
EMC Directive		EN55011, EN61000-6-2, EN61000-4-2/3/4/6/8									
Weight (main body only)	*4	S06	Approx. 85 g								
		S08	Approx. 105 g								
		SM5	Approx. 130 g								
Clean room specifications	*6	P70	Dust generation preventing *8								
		P80	Oil-prohibited *9								

*1: The value converted to volumetric flow rate at standard condition (20°C 1 barometric pressure (101 kPa) relative humidity 65%)

*2: Use dry gas which does not contain corrosive elements such as chlorine, sulphur or acids, and which is clean and does not contain dust or oil mist. When using compressed air, use clean air that complies to JIS B 8392-1:2012 Class 1.1 to 1.6.2. Compressed air from the compressor contains drainage-water, oil oxide, foreign matters, etc. To maintain the function of this product, install a filter, air dryer (min. pressure dew point 10°C or less), and oil mist filter (max. oil concentration 0.1 mg/m³) on the primary side (upper stream side) of this product.

[Recommended circuit]

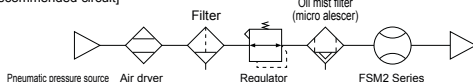

[Recommended device]

Air filter: F Series
Oil mist filter: M Series

*3: Calibration of this product is performed within specified range. Accuracy conditions: Temperature 25±3°C, power supply voltage 24±0.01 VDC. F.S. stands for full scale flow rate.

*4: The output impedance of the analog output section is approx. 1 kΩ. If the impedance of the connecting load is small, output and error increase. Check error with the impedance of the connecting load before using.

*5: The power supply voltage specifications differ for the voltage output and current output.

*6: Current for when 24 VDC is connected, and no load is connected. The current consumption will vary depending on how the load is connected.

*7: This product's protection circuit is effective only for specific misconnections and load short-circuits. It does not provide protection for all misconnections.

*8: [P70] Dust generation preventing (product surface is degreased and cleaned before packing. Heat sealed into anti-static bag in clean bench (Class 1000 and over)).

*9: [P80] Oil-prohibited (In addition to P70 specifications, wetted sections are degreased and cleaned. Refer to the "Internal structure drawing and parts list" for details on the wetted section members.)

SCPD3
SCM
MDC2
SMG
SSD2
STM
STG
LCR
LCG
LCX
LCM
STR2
MRL2
GRC
Cylinder switch
MN3E
MN4E
4GA/B
M4GA/B
MN4GA/B
F.R.(module unit)
Clean F.R.
Precision R
Press.gauge
Diff.press.gauge
Electro-pneumatic R
Speed controller
Auxiliary valve
Fitting/tube
Clean air unit
Pressure sensor
Flow rate sensor
Valve for air blow
Ending

Separate indicator specifications

Descriptions		Separated indicator FSM2 - D - (*1) (*2) - * - (*3)		
MDC2	Settable flow rate range *1	mℓ	5, 10, 50, 100, 500	
SMG		ℓ	1, 2, 4, 5, 10, 12, 20, 25, 32, 50, 100, 200, 500, 1000, 1500	
SSD2	Operating ambient temperature/humidity		0°C (32°F) to 50°C (122°F)	
STM	Type of display		4 digit + 4 digit 2-color LCD	
STG	Input voltage		1 to 5 V	
LCR	Output	Switch output *1	N	Output 2 points (NPN open collector output, 50 mA or less, voltage drop 2.4 V or less)
			P	Output 2 points (PNP open collector output, 50 mA or less, voltage drop 2.4 V or less)
LCG	Analog output *2	V	1 to 5 V voltage output 1 point (connecting load impedance 50 kΩ and over) *6	
		A	4 to 20 mA current output 1 point (connecting load impedance 0 to 300 Ω)	
LCX	Power supply voltage *2	V	12 to 24 VDC (10.8 to 26.4 V)	
		A	24 VDC (21.6 to 26.4 V)	
LCM	Current consumption *2		40 mA or less (when 24 VDC is connected, and no load is connected)	
STR2	Cable		ø 3.7, AWG26 or equivalent × 5-conductors (connector connection), insulator outer diameter ø 1.0	
MRL2	Holding function		Flow rate display, flow rate display peak hold, switch output, analog output	
GRC	Degree of protection		IEC standards IP40 or equivalent	
	Protection circuit *3		Power supply reverse connection protection	
Cylinder switch	EMC Directive		EN55011, EN61000-6-2, EN61000-4-2/3/4/6/8	
	Accessory		1 sensor connection connector (e-con), conforming cable AWG24 to 26, insulator outer diameter ø 1.0 to 1.2	
MN3E	Weight (main body only)		Approx. 40 g	
MN4E	Clean room specifications *4 *3 P70		Dust generation preventing	

- *1: The flow rate range, flow direction and gas are automatically recognized only when FSM2 display separated is connected. (default state)
The FSM-H Series, FSM-V Series and WFK3000 Series flow rate ranges are supported in addition to the FSM2 Series, but automatic recognition is supported only with the FSM2 Series. Always set the product's flow rate range, flow direction and gas type before starting use.
The connectable flow rate ranges are shown in "Display for each flow rate range" below.
When the sensor section is changed, the previous flow rate range settings, etc., will still be recorded. Always reset the settings before using.
- *2: Current for when 24 VDC is connected, and no load is connected. The current consumption will vary depending on how the load is connected.
- *3: This product's protection circuit is effective only for specific mis-connections and a load short-circuit. It does not provide protection against various mis-connections.
- *4: [P70] Dust generation preventing (product surface is degraded and cleaned before packing. Heat sealed into anti-static bag in clean bench (Class 1000 and over).)
- *5: When connecting to the FSM-V Series or WFK3000 Series, the cable size is different so the separate compatible sensor connection connector (e-con) will be required. Contact your nearest CKD sales office or dealer.
The enclosed sensor connection connector (e-con) can be used with the FSM Series and FSM-H Series.
- *6: The output impedance of the analog output section is approx. 1 kΩ. If the impedance of the connecting load is small, output and error increase. Check error with the impedance of the connecting load before using.

Display for each flow rate range

Flow rate display	Display range	0 to		2.00		5.00		12.0		25.0		50.0		100.0		200		500		1000		1.50		5.00		10.00		50.0		100.0	
		Uni-direction	500	1000	2.00	4.00	5.00	10.00	12.0	20.0	25.0	32.0	50.0	100.0	200	500	1000	1.50	5.00	10.00	50.0	100.0	0.01	0.1	1.0	10.0	100.0	0.1	1.0	10.0	100.0
*1	Bi-direction	-500	-1000	-2.00	-	-5.00	-10.00	-	-20.0	-	-	-50.0	-100.0	-200	-500	-1000	-1.50	-5.00	-10.00	-50.0	-100.0	0.01	0.1	1.0	10.0	100.0	0.1	1.0	10.0	100.0	
		500	1000	2.00	-	5.00	10.00	-	20.0	-	-	50.0	100.0	200	500	1000	1.50	5.00	10.00	50.0	100.0	0.01	0.1	1.0	10.0	100.0	0.1	1.0	10.0	100.0	
*2	Display resolution	1 mℓ/min				0.01 ℓ/min				0.1 ℓ/min				1 ℓ/min				0.01 mℓ/min		0.01 mℓ/min		0.1 mℓ/min		0.1 mℓ/min							
	Display range	9999999 mℓ				99999.99 ℓ				9999999.9 ℓ				99999999 ℓ				99999.99 mℓ		999999.99 mℓ		9999999.9 mℓ		9999999.9 mℓ							
	Display resolution	1 mℓ				0.01 ℓ				0.1 ℓ				1 ℓ				0.01 mℓ		0.01 mℓ		0.1 mℓ		0.1 mℓ							
	Integrated pulse output rate	5 mℓ	10 mℓ	0.02 ℓ	0.04 ℓ	0.05 ℓ	0.1 ℓ	0.12 ℓ	0.2 ℓ	0.25 ℓ	0.32 ℓ	0.5 ℓ	1 ℓ	2 ℓ	5 ℓ	10 ℓ	15 ℓ	0.05 mℓ	0.1 mℓ	0.5 mℓ	1 mℓ	1 mℓ	1 mℓ	1 mℓ	1 mℓ	1 mℓ	1 mℓ	1 mℓ	1 mℓ	1 mℓ	1 mℓ

- *1: The flow rate display is rounded off at approx. 1% F.S. or less (forced zero).
- *2: The integrating flow is a calculated (reference) value. It will be reset when the power is turned OFF.
- * The voltage output (1-5 V) sensor is supported. If the current output or other voltage output type is connected, it will not operate properly.

Discontinue

MEMO

SCPD3

SCM

MDC2

SMG

SSD2

STM

STG

LCR

LCG

LCX

LCM

STR2

MRL2

GRC

Cylinder
switch

MN3E
MN4E

4GA/B

M4GA/B

MN4GA/B

F.R.(module
unit)

Clean
F.R.

Precision
R

Press.gauge
Dif.press.gauge

Electro-
pneumatic R

Speed
controller

Auxiliary
valve

Fitting/
tube

Clean
air unit

Pressure
sensor

Flow rate
sensor

Valve for
air blow

Ending

How to order

● Display integrated, display separated, needle valve integrated

FSM2 - A V R 005 - S06 AR 1 B K N - P70

A Output

B Analog output
*2

C Flow direction

D Flow rate range

* Refer to the table on the next page for the flow rate range, port size (body material), and gas combinations.

E Port size (body material)
*3

F Gas type

G Cable

H Bracket

I Traceability

J With needle valve

K Clean room specifications

Code	Content
A Output	
A **	Display separated (analog output 1 point only) (Not available with needle valve integrated)
N	Display integrated (switch output (NPN) 2 points, analog output 1 point)
P	Display integrated (switch output (PNP) 2 points, analog output 1 point)
B Analog output	
V	Voltage output (1-5 V)
A	Current output (4-20 mA)
C Flow direction	
F	Uni-direction
R	Bi-direction (Not available with needle valve integrated)
D Flow rate range (full scale flow rate)	
005	500 ml/min
010	1 l/min
020	2 l/min
050	5 l/min
100	10 l/min
200	20 l/min
500	50 l/min
101	100 l/min
201	200 l/min
501	500 l/min (Not available with needle valve integrated)
102	1000 l/min (Not available with needle valve integrated)
E Port size (body material)	
H04	Push-in ø 4 (resin)
H06	Push-in ø 6 (resin)
H08	Push-in ø 8 (resin)
H10	Push-in ø 10 (resin)
S06	Rc1/8 (stainless steel)
S08	Rc1/4 (stainless steel)
A15	Rc1/2 (aluminum) (Not available with needle valve integrated)
SM5	M5 (stainless steel) (custom order product) (Not available with needle valve integrated)
F Gas type	
Blank	Air, nitrogen gas
AR	Argon
C2	Carbon dioxide (CO ₂)
G Cable	
Blank	None
1	1 m
3	3 m
H Bracket	
Blank	None
B	With bracket
P *1	Panel mounting kit
I Traceability	
Blank	None
T	Traceability certification with series variation diagram and company certification
K	With company certification
J With needle valve	
Blank	None
N	Needle valve integrated
K Clean room specifications	
Blank	None
P70	Dust generation preventing
P80	Oil-prohibited

[Example of model No.]

FSM2-NVF005-S06AR1BKN-P70

Model: RAPIFLOW FSM2

- A Output : Display integrated (NPN)
- B Analog output : Voltage output (1-5 V)
- C Flow direction : Uni-direction
- D Flow rate range : 500 ml/min
- E Port size (body material) : Rc1/8 (stainless steel)
- F Gas : Argon
- G Cable : 1 m
- H Bracket : With bracket
- I Traceability : With company certification
- J With needle valve : With needle valve
- K Clean room specifications : Dust generation preventing

⚠ Precautions for model No. selection

- *1: For the A output "A", B the panel mounting option "P" cannot be selected.
The separated indicator is not enclosed with the A output "A".
- *2: When using the FSM2-D for the separated indicator with the display separated, select "V".
- *3: For E port size "A15", H panel mounting option "P" cannot be selected.

- SCPD3
- SCM
- MDC2
- SMG
- SSD2
- STM
- STG
- LCR
- LCG
- LCX
- LCM
- STR2
- MRL2
- GRC
- Cylinder switch
- MN3E
MN4E
- 4GA/B
- M4GA/B
- MN4GA/B
- F.R. (module unit)
- Clean F.R.
- Precision R
- Press gauge
Diff. press gauge
- Electro-pneumatic R
- Speed controller
- Auxiliary valve
- Fitting/tube
- Clean air unit
- Pressure sensor
- Flow rate sensor
- Valve for air blow
- Ending

Discontinue

FSM2-D Series is on sale.

Please refer to FSM3 Series.

FSM2 Series

How to order

Combination of flow rate range, port size (body material), gas type and needle valve integrated.

		E Port size (body material)							
		H04	H06	H08	H10	S06	S08	A15	SM5
D Flow rate range	005	●◆	●◆			●○△◆			●○△
	010	●◆	●◆			●○△◆			●○△
	020	●◆	●◆			●○△◆			●○△
	050	●◆	●◆			●○△◆			●○△
	100	●◆	●◆			●○△◆			●○△
	200	●◆	●◆			●○△◆			●○
	500		●◆	●◆		●○△◆	●○△◆		
	101			●◆	●◆		●○△◆		
	201			●◆	●◆		●○△◆		
	501							●	
102							●		

F Gas types

● : Air, nitrogen gas

○ : Argon

△ : Carbon dioxide (CO₂)

□ : Not available

J With needle valve

◆ : Needle valve integrated

Combination of port size and clean room specifications

		E Port size (body material tube)							
		H04	H06	H08	H10	S06	S08	A15	SM5
K Clean room specifications	P70	●	●	●	●	●	●	●	●
	P80	●	●			●	●	●	●

● : Available

□ : Not available

Discrete option model No.

FSM2 - LB1 - P70

A Option

B Clean room specifications

Code	Content
A Option	
LB1	Bracket (for ø 4, ø 6, ø 8, ø 10, Rc1/8, Rc1/4, M5)
LB2	Bracket (for Rc1/2)
KHS	Panel mounting kit (for display integrated, for separated indicator)*
KHS-N	A set of panel mounting kit (for needle valve integrated)
C51	5-conductor cable 1 m (for display integrated, for separated indicator)
C53	5-conductor cable 3 m (for display integrated, for separated indicator)
C41	4-conductor cable 1 m (for display separated)
C43	4-conductor cable 3 m (for display separated)

* The panel mounting kit cannot be mounted on the FSM2-*A15*.

Code	Content
B Clean room specifications	
Blank	None
P70	Dust generation preventing

● Separated indicator

FSM2 - D - N - V - 3 - P - P70

A Output

B Analog output

C Cable

D Bracket

E Clean room specifications

Discrete option model No.

FSM2 - KHS - P70

A Option

B Clean room specifications

Code	Content
A Output	
N	Switch output (NPN) 2 points, analog output 1 point
P	Switch output (PNP) 2 points, analog output 1 point
B Analog output	
V	Voltage output (1-5 V)
A	Current output (4-20 mA)
C Cable	
Blank	None
1	1 m
3	3 m
D Bracket	
Blank	None
P	Panel mounting kit
E Clean room specifications	
Blank	None
P70	Dust generation preventing

Code	Content
A Option	
KHS	A set of panel mounting kit
C51	5-conductor cable 1 m (for display integrated, for separated indicator)
C53	5-conductor cable 3 m (for display integrated, for separated indicator)
EC	Sensor connection connector (e-con) 5pcs. set
B Clean room specifications	
Blank	None
P70	Dust generation preventing



CAUTION The voltage output (1-5 V) sensor is supported. If the current output or other voltage output is connected, it will not operate properly. Use FSM2-AV* when using FSM2.

SCPD3
SCM
MDC2
SMG
SSD2
STM
STG
LCR
LCG
LCX
LCM
STR2
MRL2
GRC
Cylinder switch
MN3E
MN4E
4GA/B
M4GA/B
MN4GA/B
F.R.(module unit)
Clean F.R.
Precision R
Press.gauge
Diff.press.gauge
Electro-pneumatic R
Speed controller
Auxiliary valve
Fitting/tube
Clean air unit
Pressure sensor
Flow rate sensor
Valve for air blow
Ending



Dimensions (display integrated)

Display integrated, port size: push-in $\varnothing 4$, $\varnothing 6$

● FSM2-N/P□-H04/H06□-P70/P80 (full scale flow rate: 0.5, 1, 2, 5, 10, 20, 50 l/min)

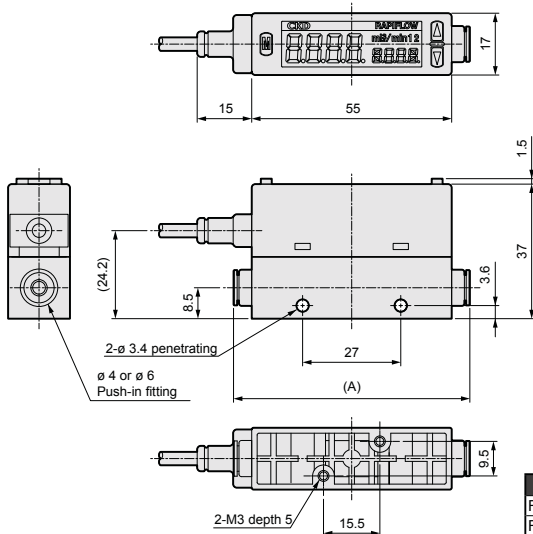

Model No.	Fitting	Dimension (A)
FSM2-N/P*-H04*	Push-in $\varnothing 4$	64.9
FSM2-N/P*-H06*	Push-in $\varnothing 6$	67.2

Display integrated, port size: push-in $\varnothing 8$, $\varnothing 10$

● FSM2-N/P□-H08/H10□-P70 (full scale flow rate: 50, 100, 200 l/min)

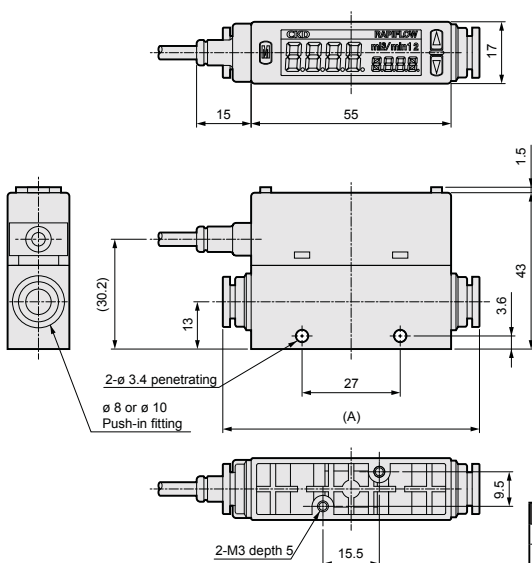

Model No.	Fitting	Dimension (A)
FSM2-N/P*-H08*	Push-in $\varnothing 8$	70.6
FSM2-N/P*-H10*	Push-in $\varnothing 10$	82.2

Dimensions (display integrated)

Display integrated, port size: Rc1/8, M5

- FSM2-N/P□-S06/SM5□-P70/P80 (full scale flow rate: 0.5, 1, 2, 5, 10, 20, 50 l/min)

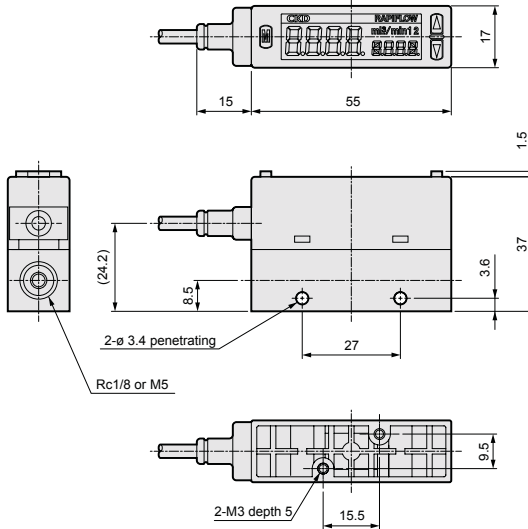

Display integrated, port size: Rc1/4

- FSM2-N/P*-S08*-P70/P80 (full scale flow rate: 50, 100, 200 l/min)

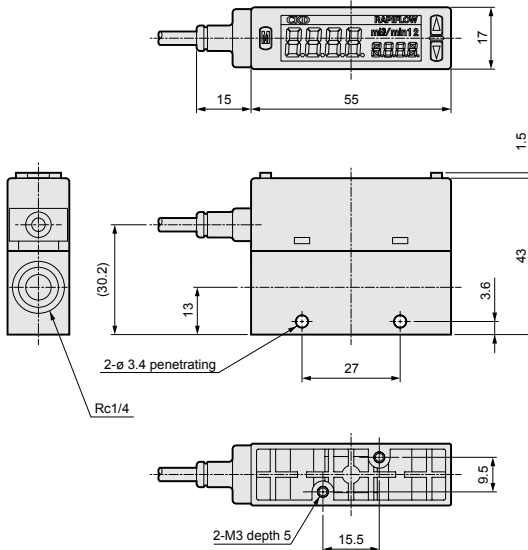

SCPD3
SCM
MDC2
SMG
SSD2
STM
STG
LCR
LCG
LCX
LCM
STR2
MRL2
GRC
Cylinder switch
MN3E MN4E
4GA/B
M4GA/B
MN4GA/B
F.R.(module unit)
Clean F.R.
Precision R
Press.gauge Diff.press.gauge
Electro-pneumatic R
Speed controller
Auxiliary valve
Fitting/tube
Clean air unit
Pressure sensor
Flow rate sensor
Valve for air blow
Ending



Dimensions (display integrated)

Display integrated, port size: Rc1/2

● FSM2-N/P□-A15□-P70/P80 (full scale flow rate: 500, 1000 l/min)

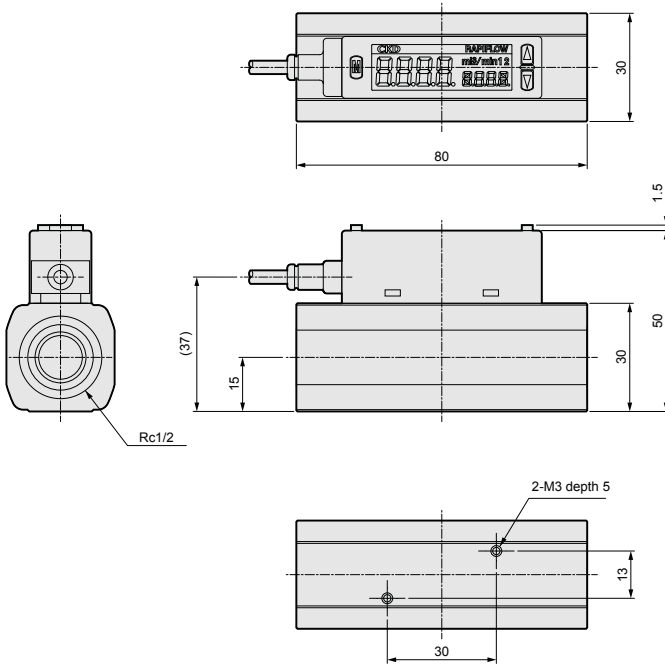

- SCP3D
- SCM
- MDC2
- SMG
- SSD2
- STM
- STG
- LCR
- LCG
- LCX
- LCM
- STR2
- MRL2
- GRC
- Cylinder switch
- MN3E
MN4E
- 4GA/B
- M4GA/B
- MN4GA/B
- F.R. (module unit)
- Clean F.R.
- Precision R
- Press gauge
Diff. press gauge
- Electro-pneumatic R
- Speed controller
- Auxiliary valve
- Fitting/
tube
- Clean air unit
- Pressure sensor
- Flow rate sensor
- Valve for air blow
- Ending

Dimensions (display separated)

Display separated, port size: push-in $\varnothing 4$, $\varnothing 6$

● FSM2-A□-H04/H06□-P70/P80 (full scale flow rate: 0.5, 1, 2, 5, 10, 20, 50 ℓ /min)

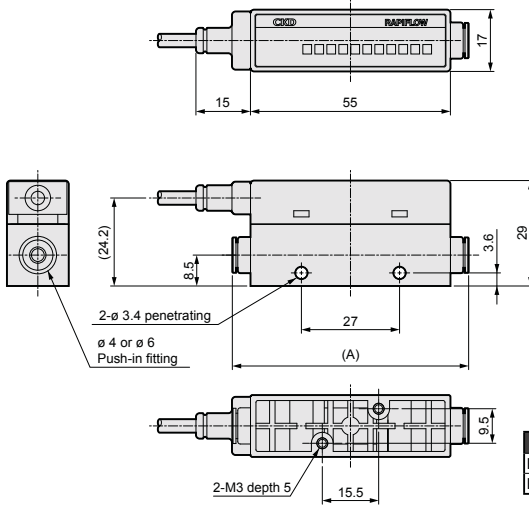

Model No.	Fitting	Dimension (A)
FSM2-A□-H04□	Push-in $\varnothing 4$	64.9
FSM2-A□-H06□	Push-in $\varnothing 6$	67.2

Display separated, port size: push-in $\varnothing 8$, $\varnothing 10$

● FSM2-A□-H08/H10□-P70 (full scale flow rate: 50, 100, 200 ℓ /min)

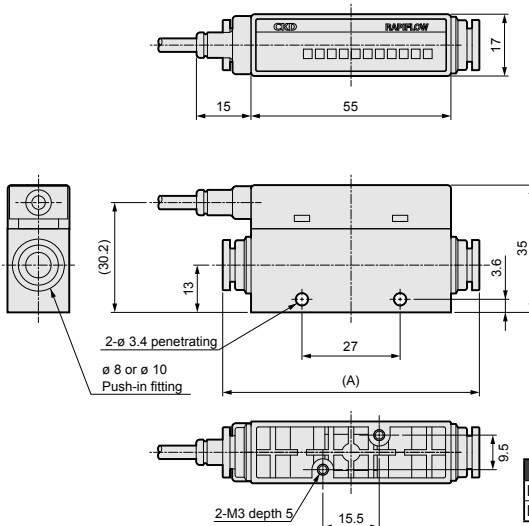

Model No.	Fitting	Dimension (A)
FSM2-A□-H08□	Push-in $\varnothing 8$	70.6
FSM2-A□-H10□	Push-in $\varnothing 10$	82.2

SCPD3
SCM
MDC2
SMG
SSD2
STM
STG
LCR
LCG
LCX
LCM
STR2
MRL2
GRC
Cylinder switch
MN3E MN4E
4GA/B
M4GA/B
MN4GA/B
F.R.(module unit)
Clean F.R.
Precision R
Press.gauge Diff.press.gauge
Electro-pneumatic R
Speed controller
Auxiliary valve
Fitting/tube
Clean air unit
Pressure sensor
Flow rate sensor
Valve for air blow
Ending



- SCPD3
- SCM
- MDC2
- SMG
- SSD2
- STM
- STG
- LCR
- LCG
- LCX
- LCM
- STR2
- MRL2
- GRC
- Cylinder switch
- MN3E
MN4E
- 4GA/B
- M4GA/B
- MN4GA/B
- F.R. (module unit)
- Clean F.R.
- Precision R
- Press gauge
Diff. press gauge
- Electro-pneumatic R
- Speed controller
- Auxiliary valve
- Fitting/tube
- Clean air unit
- Pressure sensor
- Flow rate sensor
- Valve for air blow
- Ending

Dimensions (display separated)

Display separated, port size: Rc1/8, M5

● FSM2-A□-S06/SM5□-P70/P80 (full scale flow rate: 0.5, 1, 2, 5, 10, 20, 50 l/min)

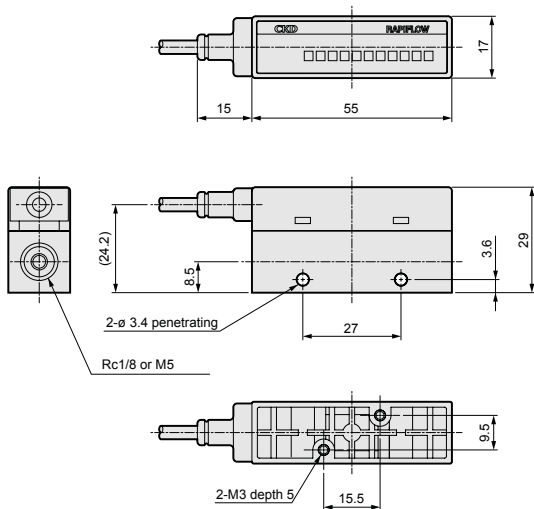

Display separated, port size: Rc1/4

● FSM2-A□-S08□-P70/P80 (full scale flow rate: 50, 100, 200 l/min)

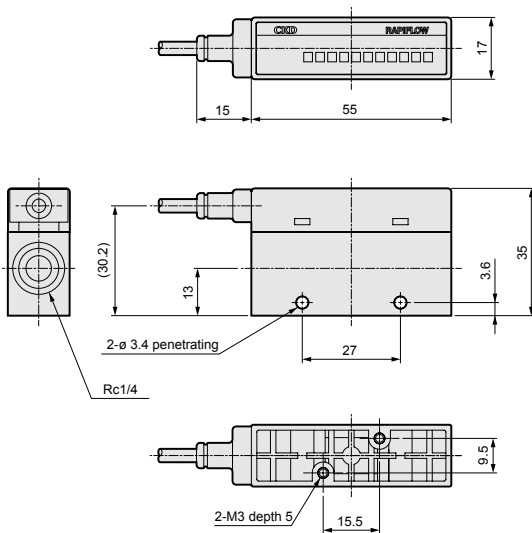

Dimensions (display separated)



Display separated, port size: Rc1/2

- FSM2-A□-A15□-P70/P80 (full scale flow rate: 500, 1000 l/min)

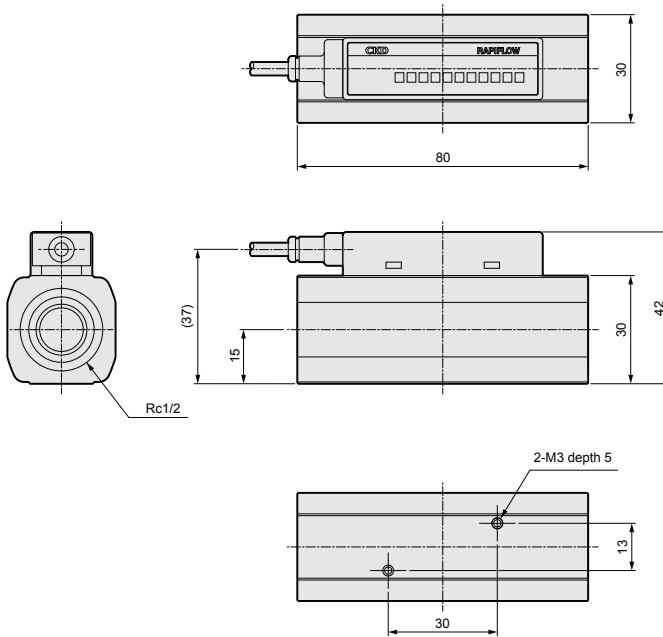

SCPD3

SCM

MDC2

SMG

SSD2

STM

STG

LCR

LCG

LCX

LCM

STR2

MRL2

GRC

Cylinder
switch

MN3E
MN4E

4GA/B

M4GA/B

MN4GA/B

F.R.(module
unit)

Clean
F.R.

Précision
R

Press.gauge
Diff.press.gauge

Electro-
pneumatic R

Speed
controller

Auxiliary
valve

Fitting/
tube

Clean
air unit

Pressure
sensor

Flow rate
sensor

Valve for
air blow

Ending



Dimensions (display integrated, needle valve integrated)

Display integrated, port size: push-in $\varnothing 4$, $\varnothing 6$

● FSM2-N/P□-H04/H06□N-P70/P80 (full scale flow rate: 0.5, 1, 2, 5, 10, 20, 50 ℓ/min)

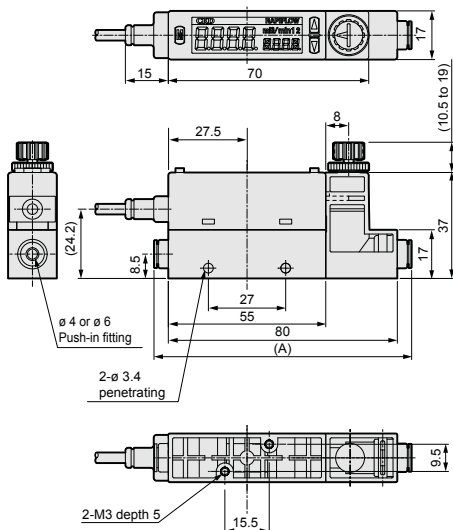

Model No.	Fitting	Dimension (A)
FSM2-N/P□-H04□	Push-in $\varnothing 4$	89.9
FSM2-N/P□-H06□	Push-in $\varnothing 6$	92.2

Display integrated, port size: push-in $\varnothing 8$, $\varnothing 10$

● FSM2-N/P□-H08/H10□N-P70 (full scale flow rate: 50, 100, 200 ℓ/min)

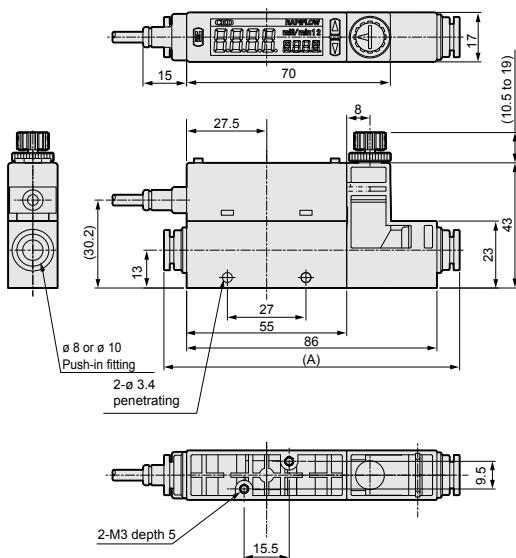

Model No.	Fitting	Dimension (A)
FSM2-N/P□-H08□	Push-in $\varnothing 8$	101.6
FSM2-N/P□-H10□	Push-in $\varnothing 10$	113.2

Dimensions (display integrated, needle valve integrated)

Display integrated, port size: Rc1/8

- FSM2-N/P□-S06□N-P70/P80 (full scale flow rate: 0.5, 1, 2, 5, 10, 20, 50 l/min)

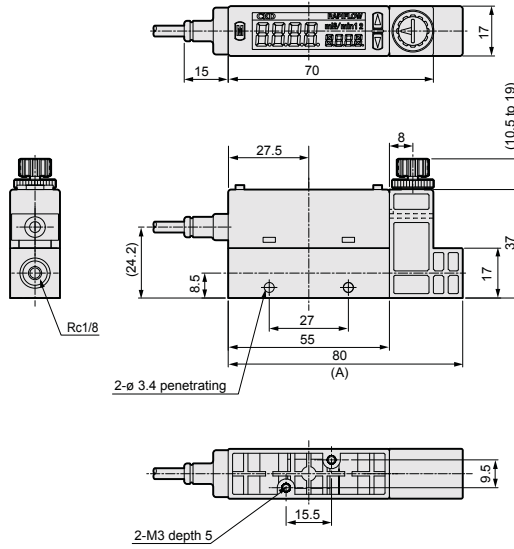

Display integrated, port size: Rc1/4

- FSM2-N/P□-S08□N-P70/P80 (full scale flow rate: 50, 100, 200 l/min)

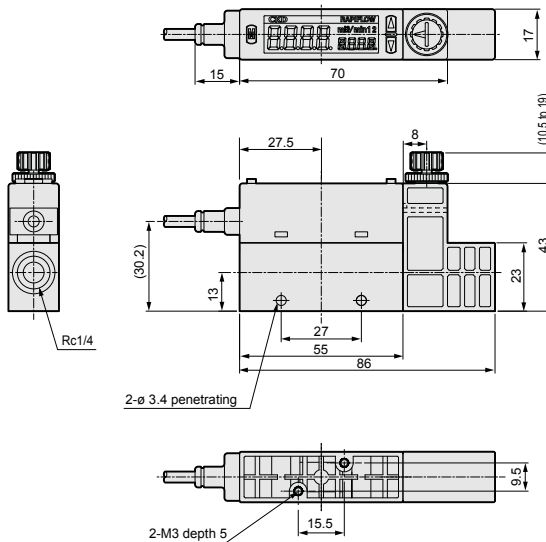

SCPD3
SCM
MDC2
SMG
SSD2
STM
STG
LCR
LCG
LCX
LCM
STR2
MRL2
GRC
Cylinder switch
MN3E MN4E
4GA/B
M4GA/B
MN4GA/B
F.R.(module unit)
Clean F.R.
Precision R
Press.gauge Diff.press.gauge
Electro-pneumatic R
Speed controller
Auxiliary valve
Fitting/tube
Clean air unit
Pressure sensor
Flow rate sensor
Valve for air blow
Ending



- SCP3D
- SCM
- MDC2
- SMG
- SSD2
- STM
- STG
- LCR
- LCG
- LCX
- LCM
- STR2
- MRL2
- GRC
- Cylinder switch
- MN3E
MN4E
- 4GA/B
- M4GA/B
- MN4GA/B
- F.R. (module unit)
- Clean F.R.
- Precision R
- Press gauge
Diff. press gauge
- Electro-pneumatic R
- Speed controller
- Auxiliary valve
- Fitting/
tube
- Clean air unit
- Pressure sensor
- Flow rate sensor
- Valve for air blow
- Ending

Dimensions with options (B: With bracket)

Display integrated, port size: push-in $\varnothing 4$, $\varnothing 6$, Rc1/8, M5

- FSM2-N/P□-H04/H06/S06/SM5□B-P70/P80 (full scale flow rate: 0.5, 1, 2, 5, 10, 20, 50 l/min)

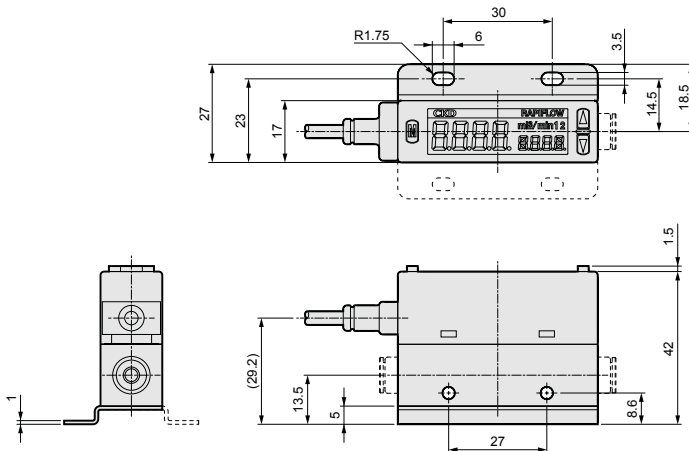

Display integrated, port size: push-in $\varnothing 8$, $\varnothing 10$, Rc1/4

- FSM2-N/P□-H08/H10□B-P70 (full scale flow rate: 50, 100, 200 l/min)

- FSM2-N/P□-S08□B-P70/P80 (full scale flow rate: 50, 100, 200 l/min)

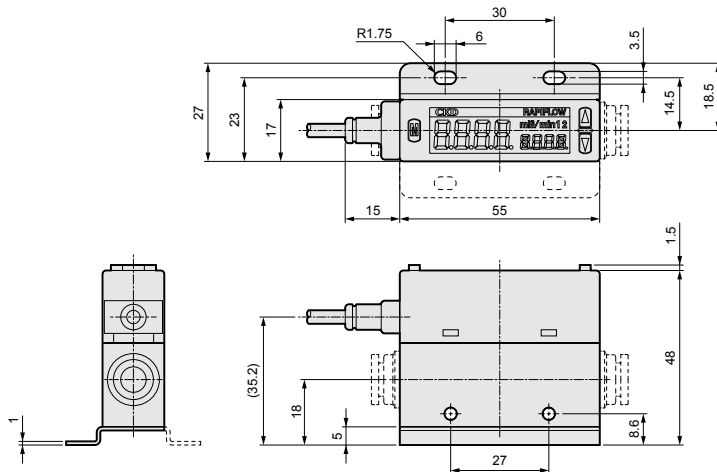

Dimensions with options (B: With bracket)

Display integrated, port size: Rc1/2

- FSM2-N/P□-A15□B-P70/P80 (full scale flow rate: 500, 1000 l/min)

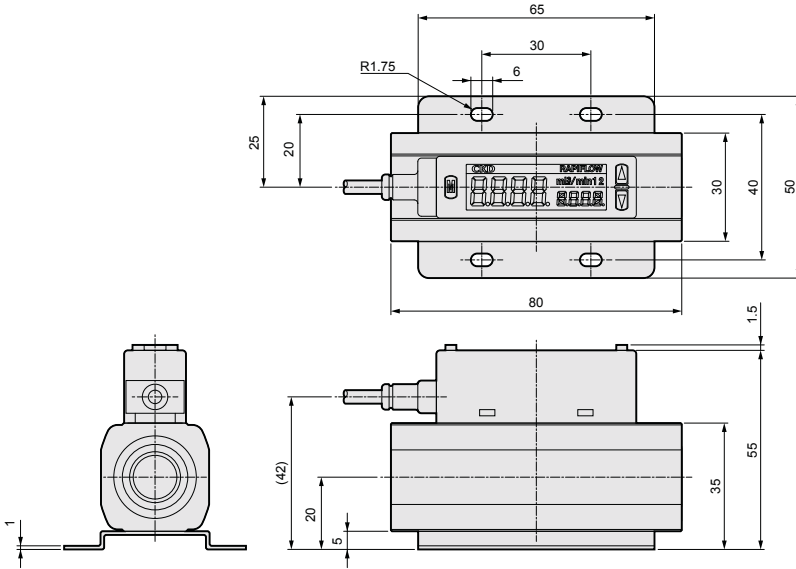

Display separated, port size: push-in \varnothing 4, \varnothing 6, Rc1/8, M5

- FSM2-A□-H04/H06/S06/SM5□B-P70/P80 (full scale flow rate: 0.5, 1, 2, 5, 10, 20, 50 l/min)

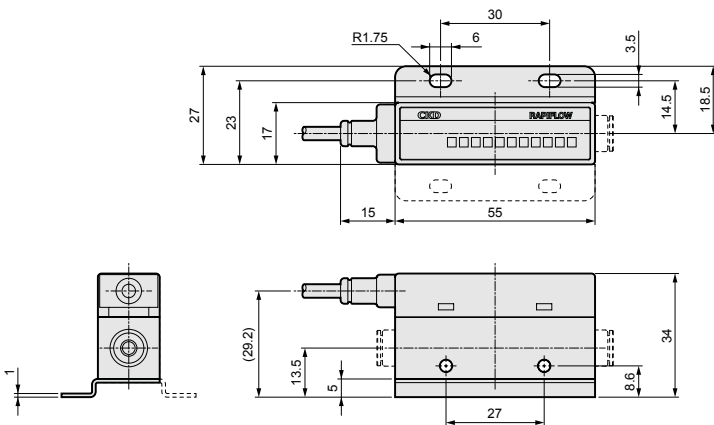

SCPD3
SCM
MDC2
SMG
SSD2
STM
STG
LCR
LCG
LCX
LCM
STR2
MRL2
GRC
Cylinder switch
MN3E MN4E
4GA/B
M4GA/B
MN4GA/B
F.R.(module unit)
Clean F.R.
Precision R
Press.gauge Diff.press.gauge
Electro-pneumatic R
Speed controller
Auxiliary valve
Fitting/tube
Clean air unit
Pressure sensor
Flow rate sensor
Valve for air blow
Ending



- SCPD3
- SCM
- MDC2
- SMG
- SSD2
- STM
- STG
- LCR
- LCG
- LCX
- LCM
- STR2
- MRL2
- GRC
- Cylinder switch
- MN3E
MN4E
- 4GA/B
- M4GA/B
- MN4GA/B
- F.R. (module unit)
- Clean F.R.
- Precision R
- Press gauge
Diff. press gauge
- Electro-pneumatic R
- Speed controller
- Auxiliary valve
- Fitting/
tube
- Clean air unit
- Pressure sensor
- Flow rate sensor
- Valve for air blow
- Ending

Dimensions with options (B: With bracket)

Display separated, port size: push-in $\varnothing 8$, $\varnothing 10$, Rc1/4

● FSM2-A□-H08/H10□B-P70 (full scale flow rate: 50, 100, 200 l/min)

● FSM2-A□-S08□B-P70/P80 (full scale flow rate: 50, 100, 200 l/min)

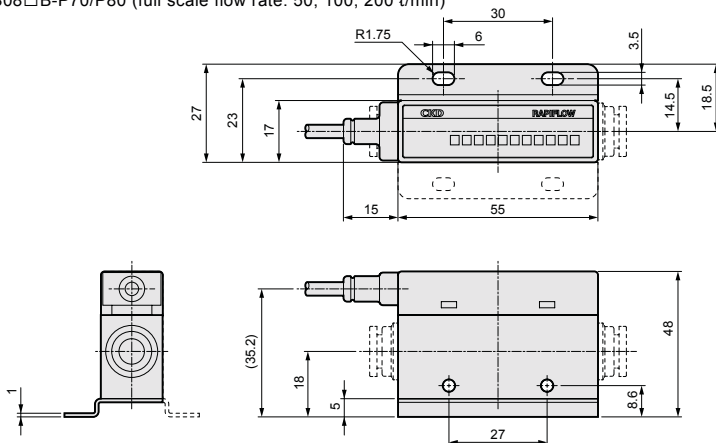

Display separated, port size: Rc1/2

● FSM2-A□-A15□B-P70/P80 (full scale flow rate: 500, 1000 l/min)

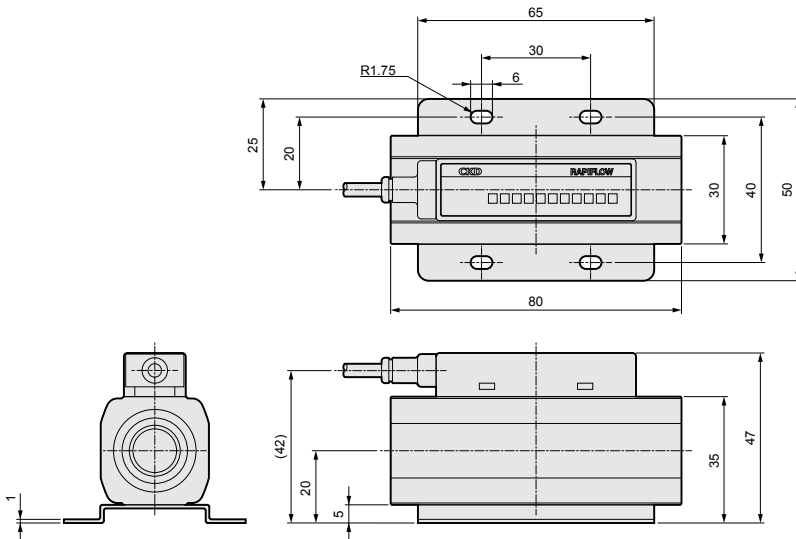

Dimensions with options (B: With bracket) 

Needle valve integrated, port size: push-in $\varnothing 4$, $\varnothing 6$, Rc1/8

- FSM2-N/P□-H04/H06/S06□BN-P70/P80 (full scale flow rate: 0.5, 1, 2, 5, 10, 20, 50 l/min)

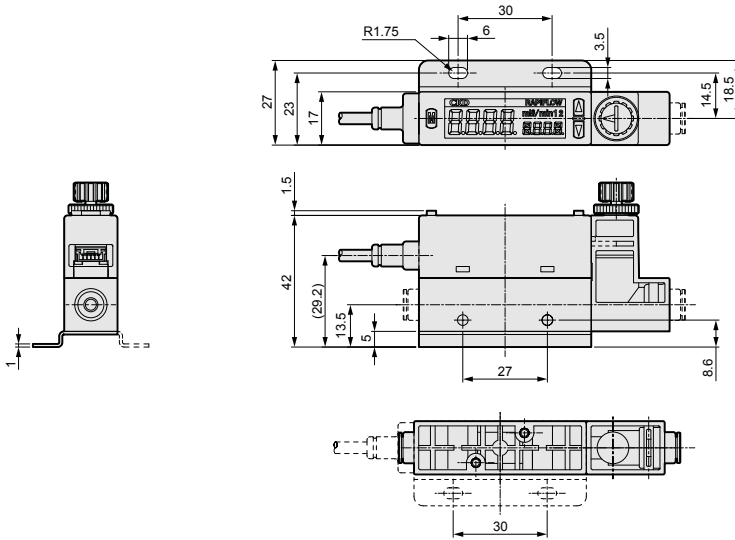

Needle valve integrated, port size: push-in $\varnothing 8$, $\varnothing 10$, Rc1/4

- FSM2-N/P□-H08/H10□BN-P70 (full scale flow rate: 50, 100, 200 l/min)
- FSM2-N/P□-S08□BN-P70/P80 (full scale flow rate: 50, 100, 200 l/min)

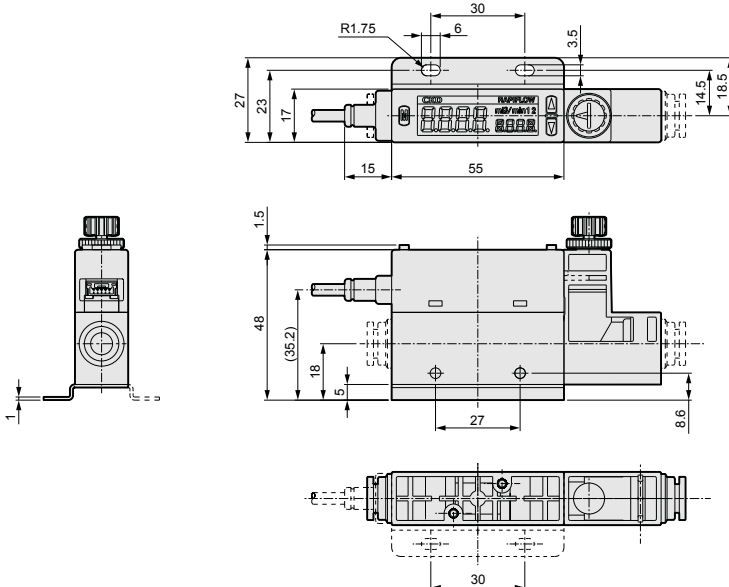

SCPD3
SCM
MDC2
SMG
SSD2
STM
STG
LCR
LCG
LCX
LCM
STR2
MRL2
GRC
Cylinder switch
MN3E MN4E
4GA/B
M4GA/B
MN4GA/B
F.R.(module unit)
Clean F.R.
Precision R
Press.gauge Diff.press.gauge
Electro-pneumatic R
Speed controller
Auxiliary valve
Fitting/tube
Clean air unit
Pressure sensor
Flow rate sensor
Valve for air blow
Ending



Dimensions with options (P: panel mounting kit with options)

● Display integrated

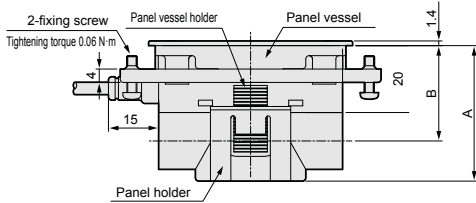
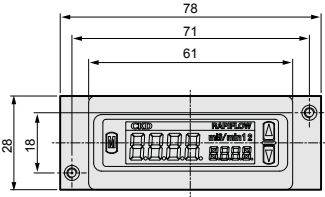

Model No.	A	B
FSM2-N/P*-H04/H06/S06/SM5*	40.5	28.5
FSM2-N/P*-H08/H10/S08*	46.5	30.0

* Cannot be mounted on FSM-N/P*-A15*. Weight: 23 g (The main unit is excluded.)

[Panel cut dimension]

In case of single installation

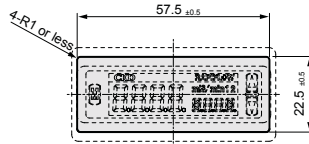

In case of continuous installation

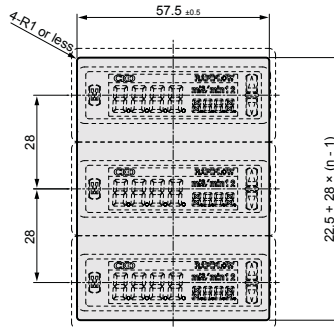

Panel thickness 6 mm or less

● Needle valve integrated

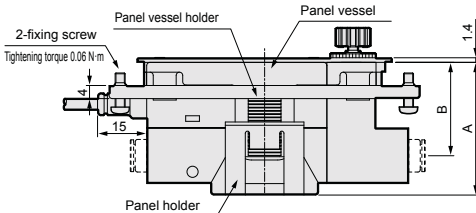
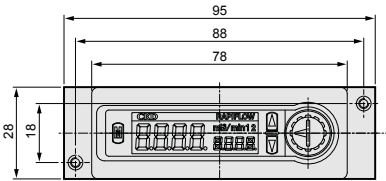

Model No.	A	B
FSM2-N/P*-H04/H06/S06*N	40.5	28.5
FSM2-N/P*-H08/H10/S08*N	46.5	30.0

Weight: 25 g (The main unit is excluded.)

[Panel cut dimension]

In case of single installation

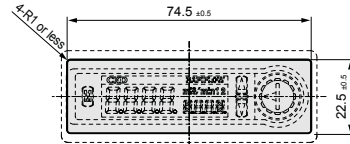

In case of continuous installation

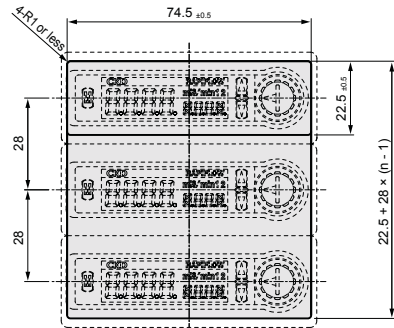

Panel thickness 6 mm or less

Optional dimensions



● Bracket

Model No. FSM2-LB1-P70

(full scale flow rate: 0.5, 1, 2, 5, 10, 20, 50, 100, 200 l/min)

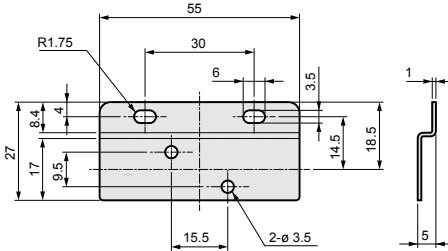

* 2 M3 fixing screws (length 6 mm) attached

Material: Steel
Weight: 13 g

Model No. FSM2-LB2-P70

(full scale flow rate: 500, 1000 l/min)

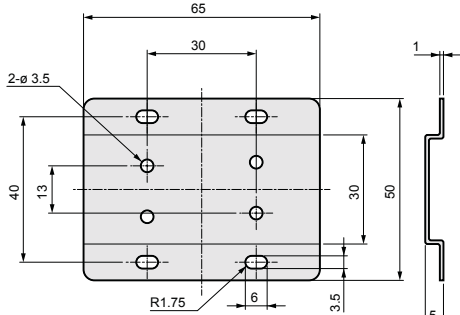

* 2 M3 fixing screws (length 6 mm) attached

Material: Steel
Weight: 28 g

● Cable option

Model No. FSM2-C51, C53-P70

5-conductor cable (for display integrated FSM2-N/P*-, for separated indicator FSM2-D)

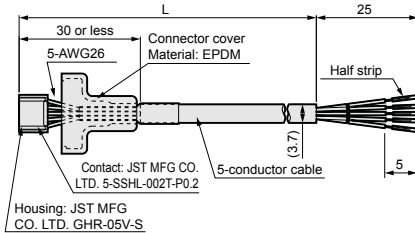

Terminal No.	Cable color
1	Brown
2	Black
3	White
4	Gray
5	Blue

Model No.	L dimensions	Weight g
FSM2-C51	1040±20	21
FSM2-C53	3040±20	57

Model No. FSM2-C41, C43-P70

4-conductor cable (for display separated FSM2-A*-))

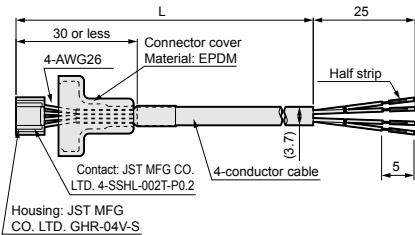

Terminal No.	Cable color
1	Brown
2	Black
3	White
4	Blue

Model No.	L dimensions	Weight g
FSM2-C41	1040±20	19
FSM2-C43	3040±20	52

- SCPD3
- SCM
- MDC2
- SMG
- SSD2
- STM
- STG
- LCR
- LCG
- LCX
- LCM
- STR2
- MRL2
- GRC
- Cylinder switch
- MN3E
- MN4E
- 4GA/B
- M4GA/B
- MN4GA/B
- F.R.(module unit)
- Clean F.R.
- Precision R
- Press gauge
- Diff. press gauge
- Electro-pneumatic R
- Speed controller
- Auxiliary valve
- Fitting/tube
- Clean air unit
- Pressure sensor
- Flow rate sensor
- Valve for air blow
- Ending



Separated indicator dimensions

● FSM2-D* -P70

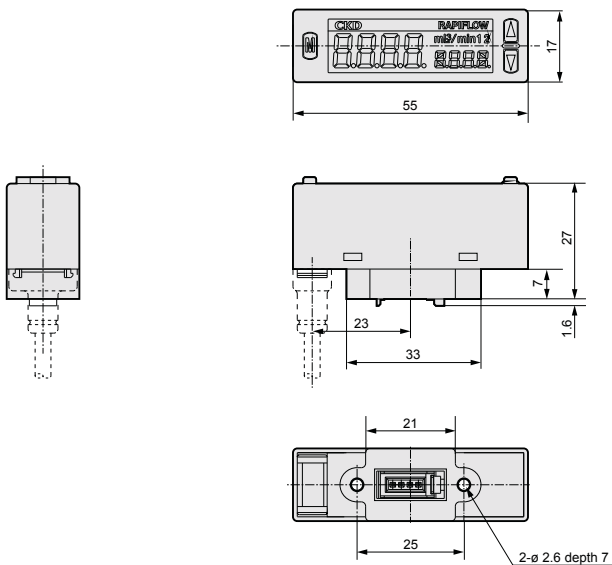

● Panel mounting kit with options dimensions

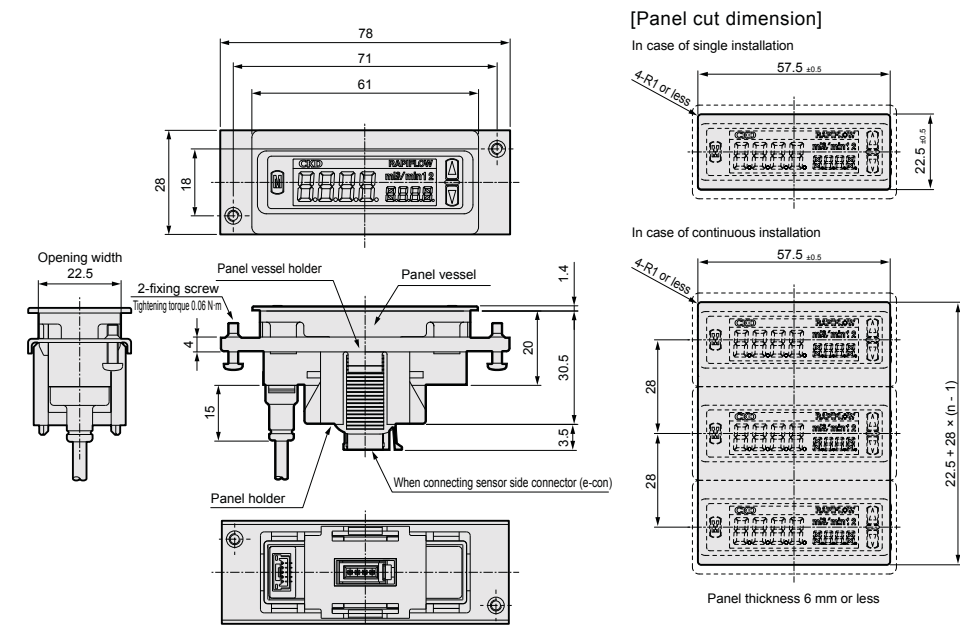

Example of internal circuit and load connection

- FSM2-N□-□ (display integrated NPN output)
- FSM2-D-N□-□ (separated indicator NPN output)

[CH2 is used as SW output]

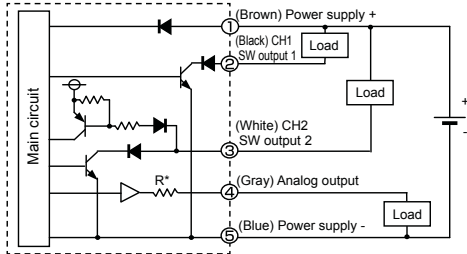

[CH2 is used as external input]

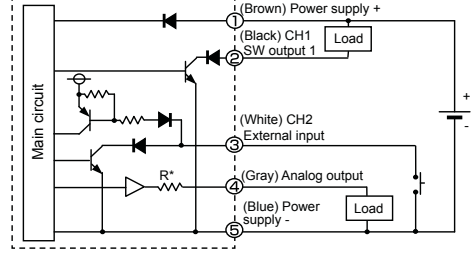

*Analog output voltage output R: Approx. 1 kΩ
Current output R: Approx. 100 Ω

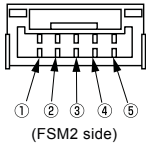

Terminal No.	Option cable color	Name
(1)	Brown	Power supply + (voltage output: 12 to 24 V, current output: 24 V)
(2)	Black	CH1 (switch output 1: max. 50 mA)
(3)	White	CH2 (switch output 2: max. 50 mA, or external input)
(4)	Gray	Analog output Voltage output: 1 to 5 V load impedance 50 kΩ and over Current output: 4 to 20 mA load impedance 300 Ω or less
(5)	Blue	Power supply - (GND)

- FSM2-P□-□ (display integrated PNP output)
- FSM2-D-P□-□ (separated indicator PNP output)

[CH2 is used as SW output]

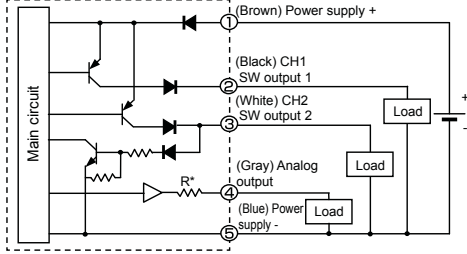

[CH2 is used as external input]

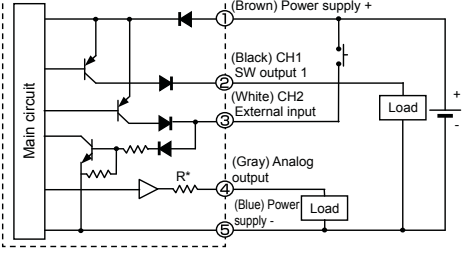

*Analog output voltage output R: Approx. 1 kΩ
Current output R: Approx. 100 Ω

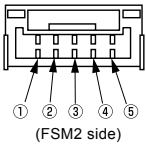

Terminal No.	Option cable color	Name
(1)	Brown	Power supply + (voltage output: 12 to 24 V, current output: 24 V)
(2)	Black	CH1 (switch output 1: max. 50 mA)
(3)	White	CH2 (switch output 2: max. 50 mA, or external input)
(4)	Gray	Analog output Voltage output: 1 to 5 V load impedance 50 kΩ and over Current output: 4 to 20 mA load impedance 300 Ω or less
(5)	Blue	Power supply - (GND)

Example of internal circuit and load connection

● FSM2-A□-□ (display separated)

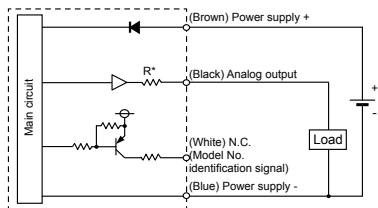

* Analog output voltage output R: Approx. 1 kΩ
Analog output current output R: Approx. 100 Ω



(FSM2 side)

Terminal No.	Option cable color	Name
(1)	Brown	Power supply + (voltage output: 12 to 24 V, current output: 24 V)
(2)	Black	Analog output Voltage output: 1 to 5 V Load impedance 50 kΩ and over Current output: 4 to 20 mA Load impedance 300 Ω or less
(3)	White	N.C. (model identification signal; do not connect when using as single part)
(4)	Blue	Power supply - (GND)

● Connecting the separated display and FSM2 indicator separated

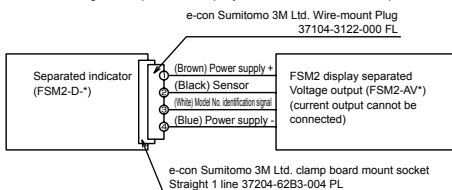

● Connecting the separated display and FSM indicator separated

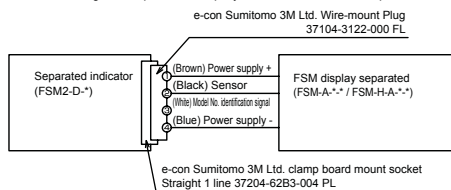

When connecting to the FSM-V Series or WFK Series, the cable size is different so the separate compatible sensor connector (e-con) will be required.

Analog output characteristics

Voltage output flow rate uni-direction

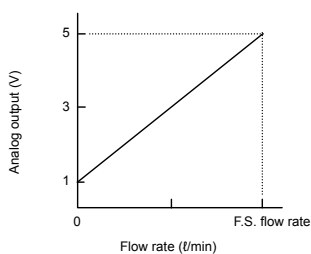

Current output flow rate uni-direction

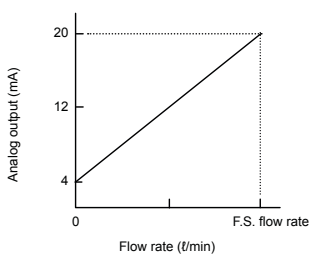

Voltage output flow rate bi-direction

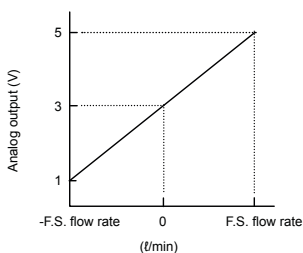

Current output flow rate bi-direction

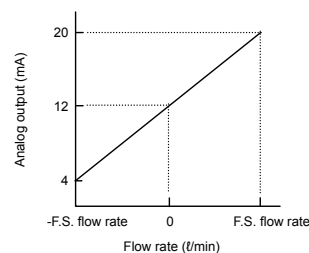

With the display integrated bi-directional, output can be changed to a uni-direction output with the button settings. Refer to page 1070 for details.

- SCPD3
- SCM
- MDC2
- SMG
- SSD2
- STM
- STG
- LCR
- LCG
- LCX
- LCM
- STR2
- MRL2
- GRC
- Cylinder switch
- MN3E
MN4E
- 4GA/B
- M4GA/B
- MN4GA/B
- F.R.(module unit)
- Clean F.R.
- Precision R
- Press gauge
Diff. press gauge
- Electro-pneumatic R
- Speed controller
- Auxiliary valve
- Fitting/tube
- Clean air unit
- Pressure sensor
- Flow rate sensor
- Valve for air blow
- Ending

Pressure loss characteristics (for air, nitrogen gas)

● FSM2-□005-□

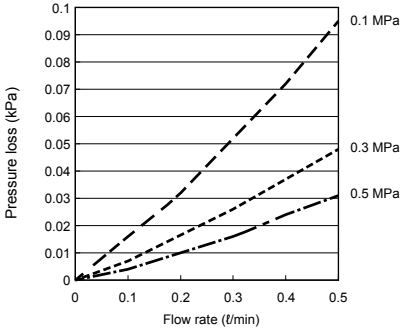

● FSM2-□010-□

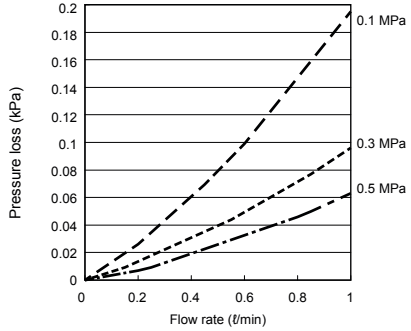

● FSM2-□020-□

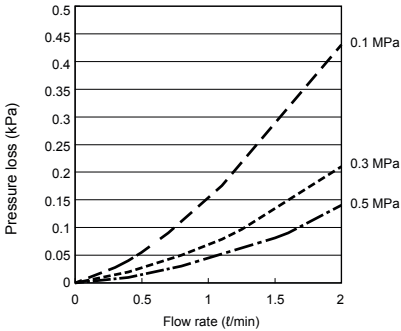

● FSM2-□050-□

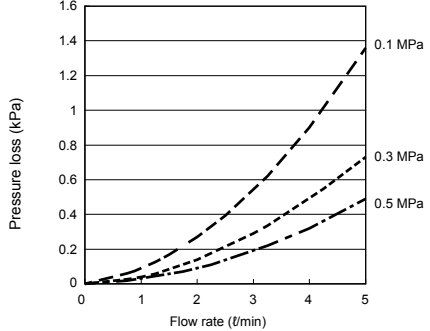

● FSM2-□100-□

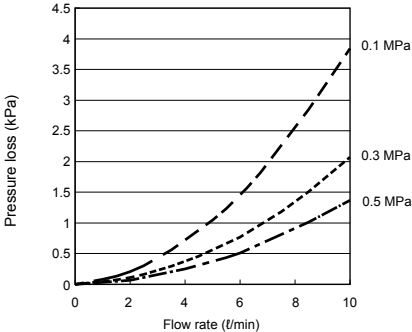

● FSM2-□200-□

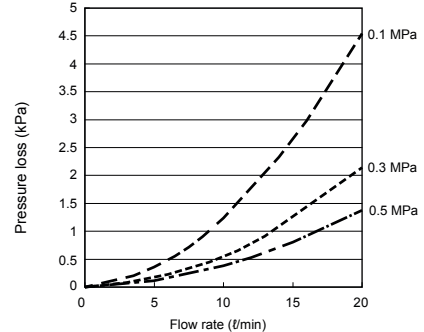

- SCPD3
- SCM
- MDC2
- SMG
- SSD2
- STM
- STG
- LCR
- LCG
- LCX
- LCM
- STR2
- MRL2
- GRC
- Cylinder switch
- MN3E MN4E
- 4GA/B
- M4GA/B
- MN4GA/B
- F.R. (module unit)
- Clean F.R.
- Precision R
- Press gauge Diff. press gauge
- Electro-pneumatic R
- Speed controller
- Auxiliary valve
- Fitting/tube
- Clean air unit
- Pressure sensor
- Flow rate sensor
- Valve for air blow
- Ending

Pressure loss characteristics (for air, nitrogen gas)

● FSM2-□500-□

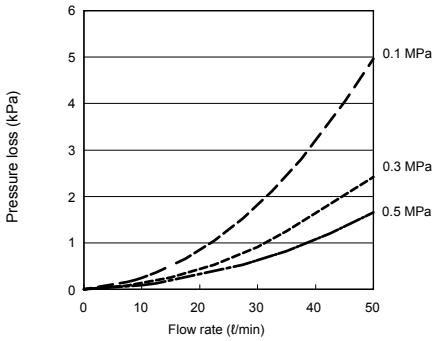

● FSM2-□101-□

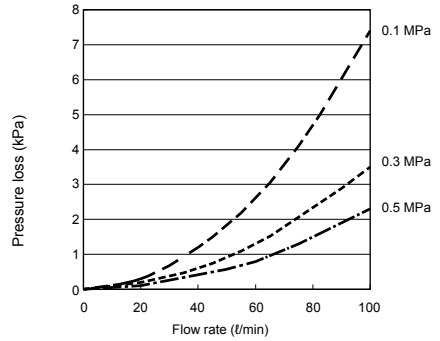

● FSM2-□201-□

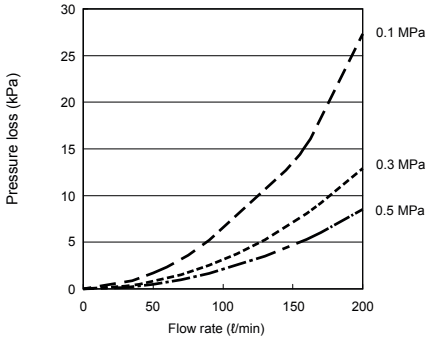

● FSM2-□501-□

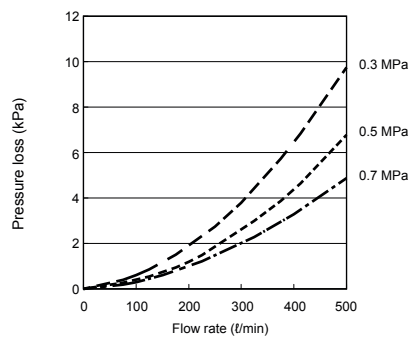

● FSM2-□102-□

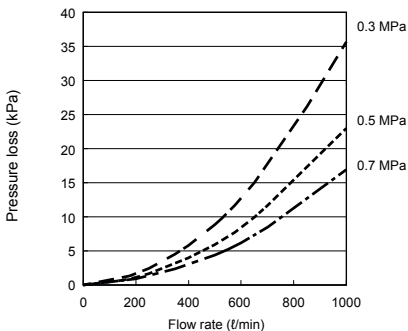

SCPD3
SCM
MDC2
SMG
SSD2
STM
STG
LCR
LCG
LCX
LCM
STR2
MRL2
GRC
Cylinder switch
MN3E MN4E
4GA/B
M4GA/B
MN4GA/B
F.R.(module unit)
Clean F.R.
Precision R
Press.gauge Diff.press.gauge
Electro-pneumatic R
Speed controller
Auxiliary valve
Fitting/tube
Clean air unit
Pressure sensor
Flow rate sensor
Valve for air blow
Ending

Pressure loss characteristics (for argon)

● FSM2-□005-□AR

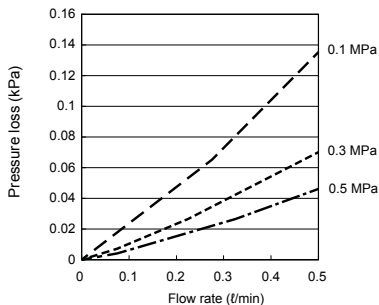

● FSM2-□010-□AR

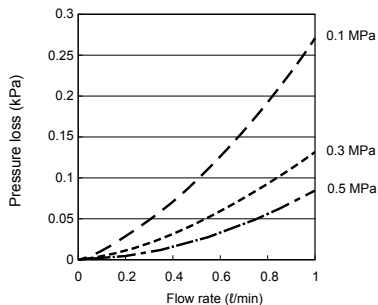

● FSM2-□020-□AR

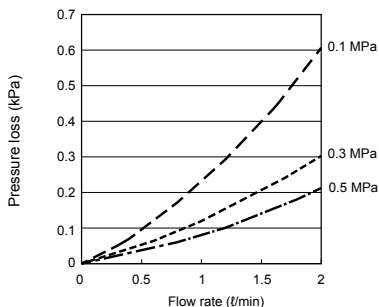

● FSM2-□050-□AR

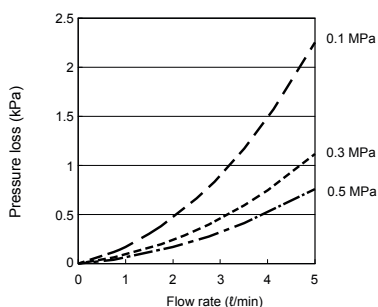

● FSM2-□100-□AR

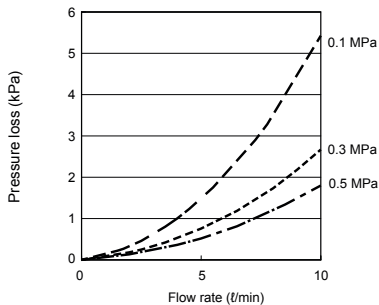

● FSM2-□200-□AR

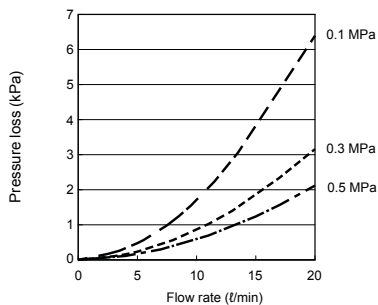

● FSM2-□500-□AR

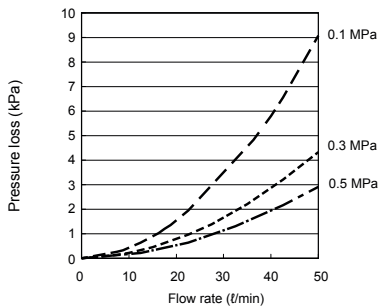

● FSM2-□101-□AR

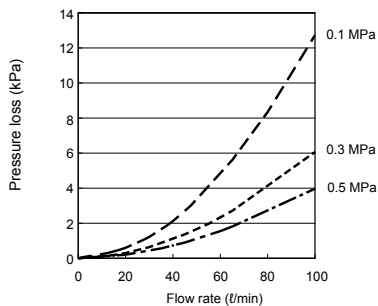

- SCPD3
- SCM
- MDC2
- SMG
- SSD2
- STM
- STG
- LCR
- LCG
- LCX
- LCM
- STR2
- MRL2
- GRC
- Cylinder switch
- MN3E
MN4E
- 4GA/B
- M4GA/B
- MN4GA/B
- F.R. (module unit)
- Clean F.R.
- Precision R
- Press gauge
Diff. press gauge
- Electro-pneumatic R
- Speed controller
- Auxiliary valve
- Fitting/tube
- Clean air unit
- Pressure sensor
- Flow rate sensor
- Valve for air blow
- Ending

Pressure loss characteristics (for carbon dioxide)

● FSM2-□005-□C2

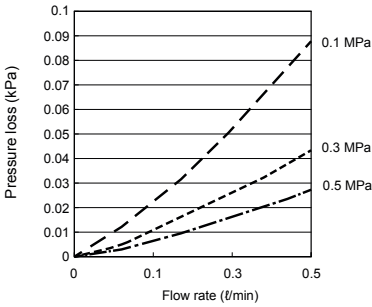

● FSM2-□010-□C2

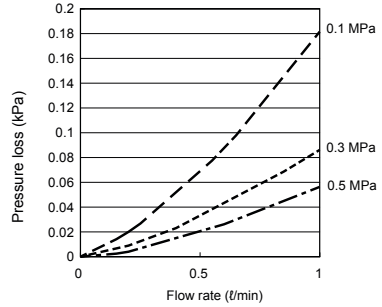

● FSM2-□020-□C2

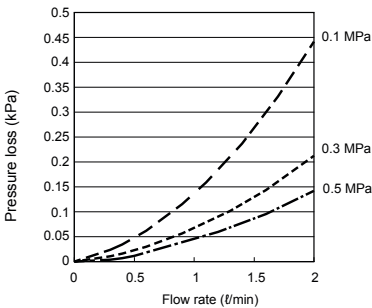

● FSM2-□050-□C2

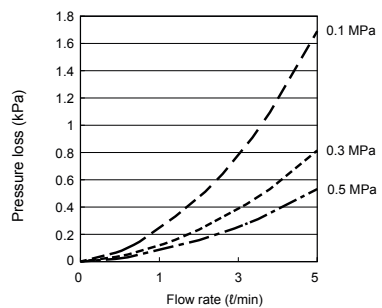

● FSM2-□100-□C2

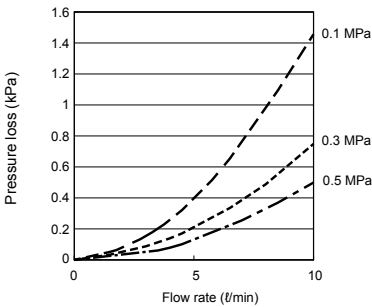

● FSM2-□200-□C2

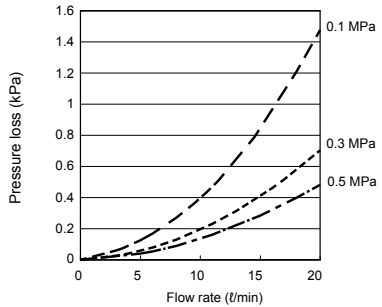

● FSM2-□500-□C2

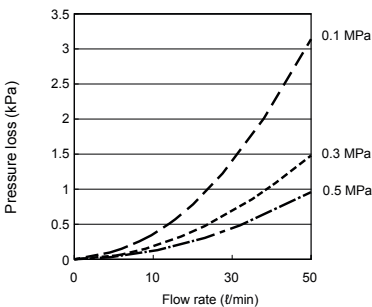

● FSM2-□101-□C2

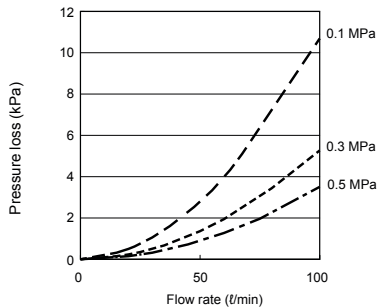

SCPD3
SCM
MDC2
SMG
SSD2
STM
STG
LCR
LCG
LCX
LCM
STR2
MRL2
GRC
Cylinder switch
MN3E
MN4E
4GA/B
M4GA/B
MN4GA/B
F.R.(module unit)
Clean F.R.
Precision R
Press.gauge
Diff.press.gauge
Electro-pneumatic R
Speed controller
Auxiliary valve
Fitting/tube
Clean air unit
Pressure sensor
Flow rate sensor
Valve for air blow
Ending

SCPD3
SCM
MDC2
SMG
SSD2
STM
STG
LCR
LCG
LCX
LCM
STR2
MRL2
GRC
Cylinder switch
MN3E MN4E
4GA/B
M4GA/B
MN4GA/B
F.R. (module unit)
Clean F.R.
Precision R
Press gauge Diff. press gauge
Electro-pneumatic R
Speed controller
Auxiliary valve
Fitting/tube
Clean air unit
Pressure sensor
Flow rate sensor
Valve for air blow
Ending

Needle valve flow characteristics (for air, nitrogen gas)

● FSM2-□005/010/020 (resin body)

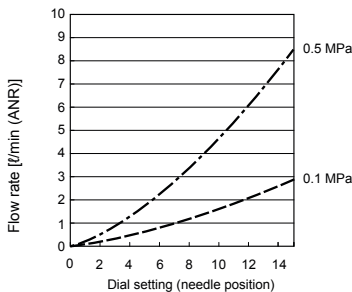

● FSM2-□050/100 (resin body)

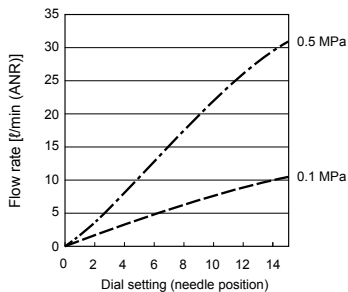

● FSM2-□200/500-H04/H06 (resin body)

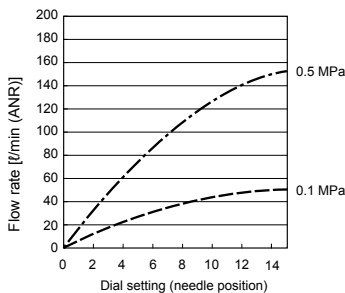

● FSM2-□500/101/201-H08/H10 (resin body)

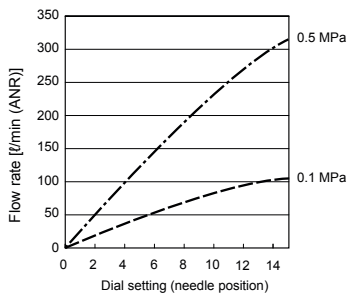

● FSM2-□005/010/020 (SUS body)

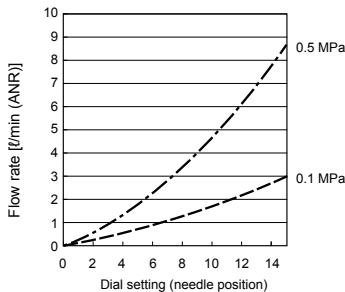

● FSM2-□050/100 (SUS body)

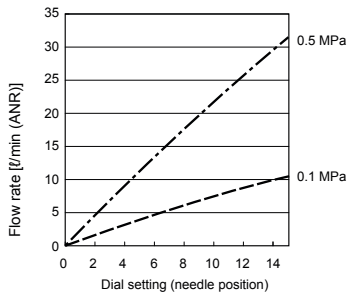

● FSM2-□200/500-S06 (SUS body)

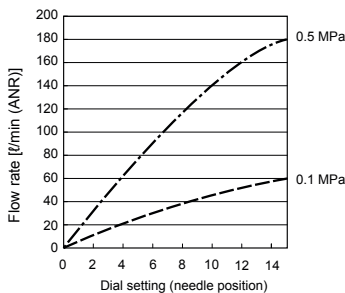

● FSM2-□500/101/201-S08 (SUS body)

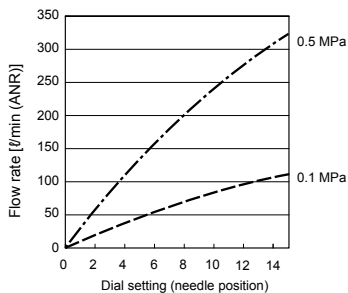

CAUTION: This characteristic value is a representative value and is not a guaranteed value.

Names and functions of display/operation section

● Display integrated

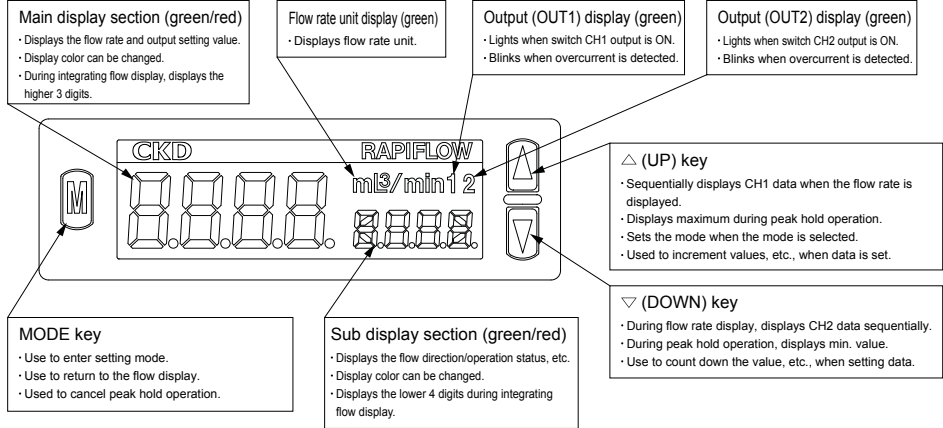

[Example of display] In case of model No. FSM2-NVR100-□

Display	Liquid crystal display
<p>Instantaneous flow rate display 10 l/min (ANR) In the case of 10L/min (ANR)</p> <p>When an excess flow of 11.0L/min runs in the opposite direction, "Lo" will be displayed. ("Lo" will be displayed at ≤-11.0L/min)</p> <p>When an excess flow of 11.0L/min runs forward, "Hi" will be displayed. ("Hi" will be displayed at ≥+11.0L/min)</p>	<p>* For bi-directional setting. (Note: In the case of a one-way type, "Lo" will be displayed at ≥.0L/min in the opposite direction or ≤-1.0L/min)</p>
<p>Integrating flow display In case of 99999.99 L</p>	<p>* When the display range of "99999.99" is exceeded, the display returns to "0.00". (It is reset.)</p>

* In the case of a one-way 10L/min type, "Hi" will be displayed at $t \geq 11L/min$ in the forward direction or $\geq +1 L/min$.

"Lo" will be displayed at $\geq 1.0L/min$ in the opposite direction or $\leq -1.0L/min$.

In the case of a two-way 10L/min type, "Hi" will be displayed if $f \geq 11.0L/min$ flows in the forward direction or $\geq +1 1.0L/min$.

"Lo" if $\geq 11.0L/min$ flows in the opposite direction or $\leq -1 1.0L/min$.

SCPD3
SCM
MDC2
SMG
SSD2
STM
STG
LCR
LCG
LCX
LCM
STR2
MRL2
GRC
Cylinder switch
MN3E
MN4E
4GA/B
M4GA/B
MN4GA/B
F.R.(module unit)
Clean F.R.
Precision R
Press.gauge
Diff.press.gauge
Electro-pneumatic R
Speed controller
Auxiliary valve
Fitting/tube
Clean air unit
Pressure sensor
Flow rate sensor
Valve for air blow
Ending

● Display separated

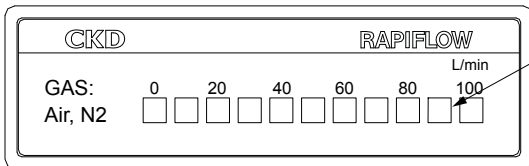





[Example of display] In case of FSM2-A□F101-□



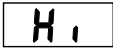

	Flow rate	Uni-direction	Bi-direction
0% F.S.			
+60% F.S. (Forward direction)			
+120% F.S. (Forward direction) Flashes at overflow. * Flashes at +10% F.S. and over			
-60% F.S. (Reverse direction)			
-120% F.S. (Reverse direction) Flashes at overflow. * Flashes at -10% F.S. and less			

Error code

● Display integrated, needle valve integrated

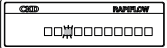
Error code	Cause	Countermeasures
	It was reset to not-corresponding flow rate when zero adjustment was performed.	Make sure to set the flow rate to zero, and then perform the zero adjustment.
	An error occurred during EEPROM reading or writing.	Then turn power ON again. If the error is not resolved, contact your CKD branch or dealer.
	An error occurred during memory reading or writing.	Then turn power ON again. If the error is not resolved, contact your CKD branch or dealer.
	The flow rate exceeds the flow rate display range.	Reduce the instantaneous flow rate value to within the flow rate range.
	Sensor failure	Then turn power ON again. If the error is not resolved, contact your CKD branch or dealer.
	The flow rate is below the flow rate display range.	Increase the instantaneous flow rate value to within the flow rate range.
	Sensor failure	Then turn power ON again. If the error is not resolved, contact your CKD branch or dealer.
Blinking of output display (Switch output is not output)	The switch output's over-current protection circuit has functioned.	Check whether load current exceeds the rating. Correctly connect, then turn power ON again.

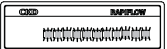
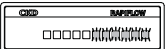
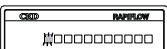
● Display separated

Error code	Cause	Countermeasures
The third from left blinks 	An error occurred during EEPROM reading or writing.	Then turn power ON again. If the error is not resolved, contact your CKD branch or dealer.
The fourth from left blinks 	An error occurred during memory reading or writing.	Then turn power ON again. If the error is not resolved, contact your CKD branch or dealer.
[Uni-direction] All blink 	The flow rate exceeds the flow rate display range.	Reduce the instantaneous flow rate value to within the flow rate range.
[Bi-direction] The right half blinks 	Sensor failure	Then turn power ON again. If the error is not resolved, contact your CKD branch or dealer.
[Uni-direction] The left most blinks 	The flow rate is below the flow rate display range.	Increase the instantaneous flow rate value to within the flow rate range.
[Bi-direction] The left half blinks 	Sensor failure	Then turn power ON again. If the error is not resolved, contact your CKD branch or dealer.

SCPD3
SCM
MDC2
SMG
SSD2
STM
STG
LCR
LCG
LCX
LCM
STR2
MRL2
GRC
Cylinder switch
MN3E
MN4E
4GA/B
M4GA/B
MN4GA/B
F.R.(module unit)
Clean F.R.
Precision R
Press.gauge
Diff.press.gauge
Electro-pneumatic R
Speed controller
Auxiliary valve
Fitting/tube
Clean air unit
Pressure sensor
Flow rate sensor
Valve for air blow
Ending

Explanation of functions (display integrated)

The functions and various settings are made during the normal flow rate display and during the setting mode. The setting mode is divided into the standard setting mode and detailed setting mode according to the frequency of use.

● Normal operation

	Descriptions	Explanation	Default setting
SCPD3	Instantaneous flow rate display	The instantaneous flow rate is displayed.	-
SCM	Integrating flow display	The integrated flow can be displayed. The switch output function includes a function to turn the switch ON/OFF at a level higher than the prescribed cumulative value, and a cumulative pulse function to output the pulse at a set cumulative value. The settings are reset at power OFF, and can also be reset with button operations or external inputs.	Instantaneous flow rate display
MDC2	Peak hold function	Max. and min. values for the flow rate within a set interval is displayed.	Peak hold OFF
SMG	Key lock function	The key operations can be invalidated to prevent inadvertent operations.	Key lock invalid
SSD2	Error display function	The error status is displayed when a fault or error occurs.	-

● Standard setting mode

	Descriptions	Explanation	Default setting
LCX	Switch output function	This product has 2-point switch output, and uses seven operation modes and a stop operation.	Switch is set to OFF for both CH1 and CH2
LCM	Forced output function	Use this function to forcibly turn the switch output ON and confirm the wiring connection or initial operation of the input device.	-
STR2	Zero adjustment function	The zero point deviation is corrected. (Range: 0±10% F.S.)	Adjust value: 0

● Detailed setting mode

	Descriptions	Explanation	Default setting
Cylinder switch	Selection of flow rate direction (Selectable only for display integrated bi-directional)	Setting the flow rate direction. Setting available for bi-directional, one-side forward direction or one-side reverse direction.	Bi-directional setting
MN3E MN4E	Selection of CH2 operation	Select the CH2 setting. Select whether to use CH2 as a switch output, or to use as an external input (cumulative value reset/auto reference).	Switch output
4GA/B	Auto reference function	When CH2 is selected as auto reference, the switch output's threshold can be imported with external inputs or button operations. The threshold can be changed automatically if the switch threshold value changes, such as when the workpiece is changed.	Auto reference function OFF
MN4GA/B	Response time setting	Set the response time. The response can be set in seven steps from 50 ms to approx. 1.5 s. Chattering and mis-operation caused by sudden flow rate changes or noise are prevented.	Response time: 50 ms
F.R.(module unit)	Display speed setting	The digital display refresh cycle can be set in three stages from 250 ms to 1 s. If the display flickers, it may be improved by setting a longer display refresh cycle.	Display speed: 250 ms
Clean F.R.	Sub-display setting	Set the sub-display section's display method. The display can be changed to flow direction, flow rate unit or gas display.	Flow direction display
Precision R	Display color setting	Set the display color. The color for a normal display and for switch output ON can be set.	Both main and sub At normal display: Green At switch ON: Red
Press gauge Diff. press gauge	Hysteresis setting	Set the switch setting value hysteresis. Use this if the flow rate pulsates or if the switch chatters near the threshold, etc.	Hysteresis: 1% F.S.
Electro-pneumatic R	Flow rate unit setting	Select the display unit from the standard state or reference state. Standard condition (ANR): Converted into volumetric flow rate at 20°C, 1 barometric pressure Reference state (NOR): Converted into volumetric flow rate at 0°C, 1 barometric pressure (Note 1)	Flow rate unit: ANR
Speed controller	ECO MODE setting	ECO mode can be set. If the buttons are not operated for approx. one minute, the ECO mode will activate and turn off the display's back light. Current consumption can be reduced with this mode.	ECO MODE OFF
Auxiliary valve	Initialization	Returns the settings to the default settings. With the separate indicator, if the settings are reset and then the power is turned ON again with the FSM2 display separated (sensor section) connected, the flow rate range will be automatically recognized.	-
Fitting/tube	Model selection (only separate indicator)	Select the flow rate range, flow direction and gas types.	Not set (Note 2)

Note 1: The reference state display is a calculated (reference) value.

Note 2: The default setting is Not set. If Not set is selected during use, the operation will start from the model selection mode after the power is turned ON. Always set the model before starting use.

The model is automatically recognized in the Not set state (default state) only when FSM2 display separated (sensor) is connected.

Switch output function

The output function can be selected from seven types of switch operations according to the required application. Functions are compatible with both CH1 and CH2.

Name of operation pattern	Explanation	Operation waveform	LCD display
Window operation (1) (ON when inside range)	The switch turns ON when the level is within the designated flow rate range.		[Sub-display section]
Window operation (2) (ON when outside range)	The switch turns ON when the level is not within the designated flow rate range.		
Hysteresis operation (1) (ON at the lower flow rate side)	The hysteresis is randomly set, and the switch output turns OFF at the designated flow rate and higher.		
Hysteresis operation (2) (ON at the higher flow rate side)	The hysteresis is randomly set, and the switch output turns ON at the designated flow rate and higher. (The output is held even during the Hi display.)		
Cumulative value output (1) (ON at integrating flow and over)	Switch output turns ON at set integrating value and higher.		
Cumulative value output (2) (OFF at integrating flow and over)	Switch output turns OFF at set cumulative value and higher.		
Integrated pulse output	The integrating pulse is output at the preset integrating value. Refer to the "Cumulative function" in the specifications for details on the preset cumulative value. (on pages 1, 2)		
Switch operation OFF	The switch operation is turned OFF.		

SCPD3
SCM
MDC2
SMG
SSD2
STM
STG
LCR
LCG
LCX
LCM
STR2
MRL2
GRC
Cylinder switch
MN3E
MN4E
4GA/B
M4GA/B
MN4GA/B
F.R.(module unit)
Clean F.R.
Precision R
Press.gauge
Diff.press.gauge
Electro-pneumatic R
Speed controller
Auxiliary valve
Fitting/tube
Clean air unit
Pressure sensor
Flow rate sensor
Valve for air blow
Ending





Automatic reference function

When CH2 is selected as auto reference, the switch output's threshold can be imported with external inputs or button operations. The threshold can be changed automatically if the switch threshold value changes, such as when the workpiece is changed. The flow rate value at the point where the external input is turned ON is read for the input value. The CH2 switch settings are invalid during auto referencing.

Number of inputs	Name of operation pattern	Explanation	Operation waveform	LCD display
1 point	ON at input value or higher	ON when higher than or equal to imported value. (Threshold: input value)		(Main display section)
	OFF at input value or higher	OFF when higher than or equal to imported value. (Threshold: input value)		(Main display section)
2 points	ON when higher than middle value of two points	ON when higher than or equal to middle value of two imported points. (Threshold: (input (1) + input (2))/2)		(Main display section)
	OFF when higher than middle value of two points	OFF when higher than or equal to middle value of two imported points. (Threshold: (input (1) + input (2))/2)		(Main display section)
	ON when between two points	ON when between two imported points. (Threshold (1): input value (1)) (Threshold (2): input value (2))		(Main display section)
	OFF when between two points	OFF when between two imported points. (Threshold (1): input value (1)) (Threshold (2): input value (2))		(Main display section)

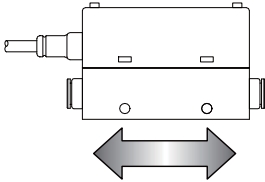
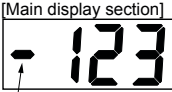
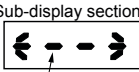
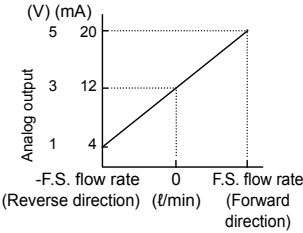
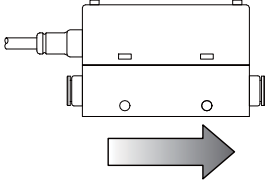
Selection of flow rate direction (Only display integrated, bi-directional)

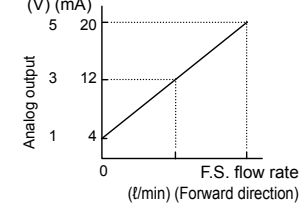
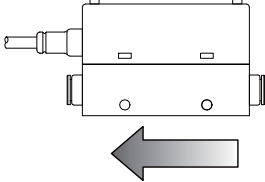
The flow rate for the display integrated, bi-directional can be set with the buttons. The value after switching is a reference value.

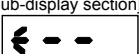
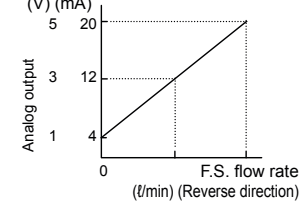
Flow direction	LCD display	Analog output characteristics
<p>[Bi-direction]</p> 	<p>[Main display section]</p>  <p>A minus mark - displays during reverse-direction flows</p> <p>[Sub-display section]</p>  <p>Arrow will change depending on the flow direction</p>	
<p>[Uni-direction (forward direction)]</p> 	<p>[Main display section]</p>  <p>[Sub-display section]</p> 	
<p>[Uni-direction (reverse direction)]</p> 	<p>[Main display section]</p>  <p>[Sub-display section]</p> 	

- SCPD3
- SCM
- MDC2
- SMG
- SSD2
- STM
- STG
- LCR
- LCG
- LCX
- LCM
- STR2
- MRL2
- GRC
- Cylinder switch
- MN3E
- MN4E
- 4GA/B
- M4GA/B
- MN4GA/B
- F.R.(module unit)
- Clean F.R.
- Precision R
- Press.gauge
- Diff.press.gauge
- Electro-pneumatic R
- Speed controller
- Auxiliary valve
- Fitting/tube
- Clean air unit
- Pressure sensor
- Flow rate sensor
- Valve for air blow
- Ending

Measurement principle of FSM2 Series

The FSM2 Series incorporates a platinum sensor chip (3 mm × 3.5 mm) machined with silicon micro-machining. The sensor is thermally insulated from the silicon substrate. The heating capacity is extremely low, enabling high sensitivity with a high-speed response. At the sensor, two temperature sensors are arranged with a heater in between. Platinum, which has a resistance that changes based on temperature, is used for the temperature sensor. When the heater is turned on and heated, the temperature distribution is symmetrical to the center of the heater if there is no flow. When flow is received, the symmetrical property of the temperature distribution is lost, and temperature upstream from the heater drops, and that downstream rises. This temperature difference appears as the difference in temperature sensor resistance, and varies with the flow rate. When the flow is reversed, the temperature difference (difference in resistance) will be inverted. By using this method, the flow rate in bi-direction can be detected. This method is suitable for detecting a relatively small flow rate.

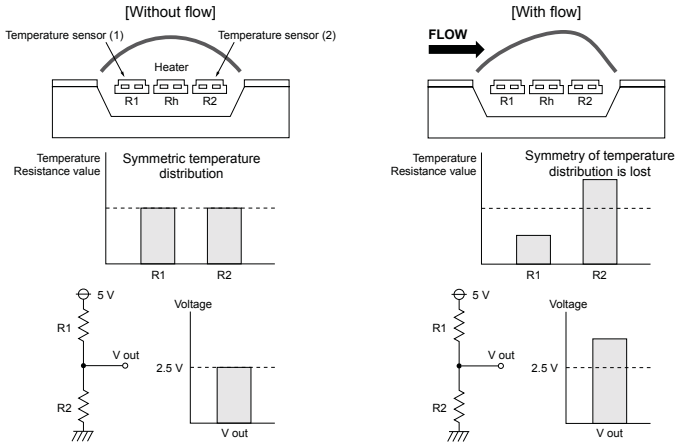

SCPD3
SCM
MDC2
SMG
SSD2
STM
STG
LCR
LCG
LCX
LCM
STR2
MRL2
GRC
Cylinder switch
MN3E MN4E
4GA/B
M4GA/B
MN4GA/B
F.R. (module unit)
Clean F.R.
Precision R
Press gauge Diff. press gauge
Electro-pneumatic R
Speed controller
Auxiliary valve
Fitting/tube
Clean air unit
Pressure sensor
Flow rate sensor
Valve for air blow
Ending

1 Flow rate sensor selection method

Use as a guide for selection of the flow rate range when using the flow rate sensor for suction/unload confirmation or leakage inspection, etc., with the suction nozzle.

The flow rate can be calculated using the effective cross-sectional area of nozzle (pinhole) and the pressure difference inside and outside of nozzle.

- $P_1 \geq 1.89P_2$ (acoustic velocity)
 $Q = 113.2 \times S \times \sqrt{P_1}$

- $P_1 < 1.89P_2$ (subsonic velocity)
 $Q = 226.4 \times S \times \sqrt{P_2 (P_1 - P_2)}$

- Q : Flow rate ℓ/min
 P₁ : Primary absolute pressure MPa
 P₂ : Secondary absolute pressure MPa
 S : Effective cross-sectional area of nozzle (pinhole) mm²

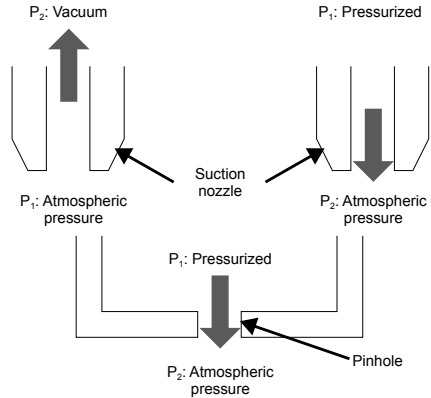

● Example of calculation

The figure below shows the calculated value of flow rate when the nozzle diameter is ø 0.1 to 2 and P₂ is varied.

	P ₁ (MPa) Absolute pressure	P ₁ (MPa) Gauge pressure	P ₂ (MPa) Absolute pressure	P ₂ (MPa) Gauge pressure	Acoustic velocity Subsonic velocity	Calculated value of flow rate (ℓ/min)									
						ø 0.1	ø 0.2	ø 0.3	ø 0.4	ø 0.5	ø 0.7	ø 1	ø 1.5	ø 2	
Vacuum	0.1013	0	0.0313	-0.07	Acoustic velocity	0.090	0.360	0.810	1.440	2.250	4.411	9.002	20.254	36.007	
	0.1013	0	0.0413	-0.06	Acoustic velocity	0.090	0.360	0.810	1.440	2.250	4.411	9.002	20.254	36.007	
	0.1013	0	0.0513	-0.05	Acoustic velocity	0.090	0.360	0.810	1.440	2.250	4.411	9.002	20.254	36.007	
	0.1013	0	0.0613	-0.04	Subsonic	0.088	0.352	0.792	1.408	2.200	4.312	8.800	19.801	35.202	
	0.1013	0	0.0713	-0.03	Subsonic	0.082	0.329	0.740	1.315	2.055	4.028	8.220	18.494	32.878	
	0.1013	0	0.0813	-0.02	Subsonic	0.072	0.287	0.645	1.147	1.792	3.512	7.166	16.125	28.666	
Blow (leakage inspection)	0.1013	0	0.0913	-0.01	Subsonic	0.054	0.215	0.483	0.859	1.343	2.631	5.370	12.083	21.480	
	0.1113	0.01	0.1013	0	Subsonic	0.057	0.226	0.509	0.905	1.414	2.772	5.657	12.727	22.626	
	0.1213	0.02	0.1013	0	Subsonic	0.080	0.320	0.720	1.280	2.000	3.920	8.000	17.999	31.998	
	0.1413	0.04	0.1013	0	Subsonic	0.113	0.453	1.018	1.810	2.828	5.543	11.313	25.454	45.252	
	0.1613	0.06	0.1013	0	Subsonic	0.139	0.554	1.247	2.217	3.464	6.789	13.856	31.175	55.423	
	0.1813	0.08	0.1013	0	Subsonic	0.160	0.640	1.440	2.560	4.000	7.840	15.999	35.998	63.996	
	0.2013	0.1	0.1013	0	Acoustic velocity	0.179	0.716	1.610	2.862	4.472	8.765	17.888	40.248	71.552	
	0.3013	0.2	0.1013	0	Acoustic velocity	0.268	1.071	2.410	4.284	6.694	13.119	26.774	60.242	107.096	
	0.4013	0.3	0.1013	0	Acoustic velocity	0.357	1.426	3.209	5.706	8.915	17.474	35.660	80.236	142.641	
	0.5013	0.4	0.1013	0	Acoustic velocity	0.445	1.782	4.009	7.127	11.137	21.828	44.547	100.230	178.186	
	0.6013	0.5	0.1013	0	Acoustic velocity	0.534	2.137	4.809	8.549	13.358	26.182	53.433	120.224	213.731	

(CAUTION)

- When there is a leakage in the piping, etc., the actual flow rate becomes larger than the calculated value. When selecting the flow rate, consider the amount of leakage in the piping.
- When there is a portion thinner than suction nozzle diameter in the middle of piping, the flow rate may be reduced to lower than the calculated value. In addition, the suction confirmation, etc., may become impossible.
- The effective cross-sectional area is just a guide. When the nozzle is long and thin, the effective cross-sectional area becomes smaller than the opening area.
- The response time is determined by the inner volume of the piping from the flow rate sensor to suction nozzle (pinhole). When performing the high speed detection, make the inner volume of the piping small as much as possible as such by installing a flow rate sensor near the suction nozzle.

- SCPD3
- SCM
- MDC2
- SMG
- SSD2
- STM
- STG
- LCR
- LCG
- LCX
- LCM
- STR2
- MRL2
- GRC
- Cylinder switch
- MN3E
- MN4E
- 4GA/B
- M4GA/B
- MN4GA/B
- F.R.(module unit)
- Clean F.R.
- Precision R
- Press.gauge
- Diff.press.gauge
- Electro-pneumatic R
- Speed controller
- Auxiliary valve
- Fitting/tube
- Clean air unit
- Pressure sensor
- Flow rate sensor
- Valve for air blow
- Ending

About suction confirmation

1 Response time

The response time at suction confirmation is determined by inner volume of the piping or exhaust capacity of the vacuum pump, etc.
 For example, the piping dependency of the response time is as seen in the following figure in case of piping such as in the right figure. This result demonstrates that it is effective to reduce the inner volume of the piping from sensor to suction nozzle as small as possible in order to decrease the response time.

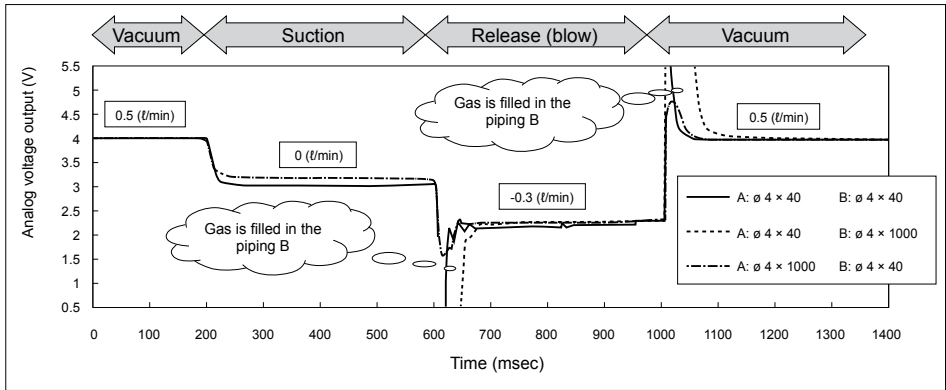
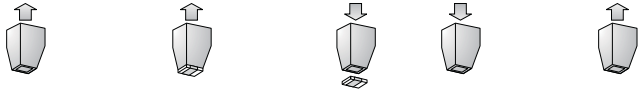
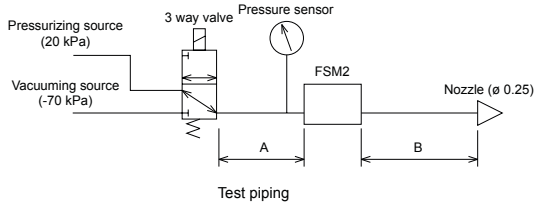

Response dependency on piping

2 In case of using a collet nozzle

The collet nozzle is commonly used when you do not want to contact the workpiece to be suctioned directly to the nozzle. Because the inside of the collet nozzle is a pyramid shape and it is such a structure that creates clearances at 4 corners when the workpiece is suctioned, a leakage occurs during the suction. If the effective cross-sectional area of the piping (including valves and fittings, etc.) compared to the clearance between the collet nozzle and workpiece (effective cross-sectional area) is small, the flow rate is determined by the effective cross-sectional area of the piping, and accordingly the flow rate difference between when suctioned and when not suctioned becomes small. At a time like this, by making the effective cross-sectional area of the piping larger than that of the clearance between the collet nozzle and workpiece as much as possible, the suction confirmation will be secured.

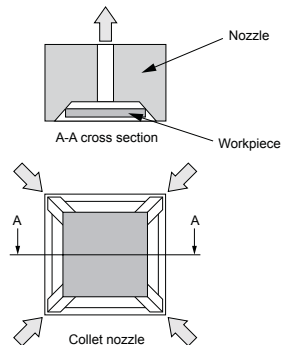



For assuring safety

Discontinue

Pneumatic components: Warning and Cautions

Always read this section before use.

SCPD3
SCM
MDC2
SMG
SSD2
STM
STG
LCR
LCG
LCX
LCM
STR2
MRL2
GRC
Cylinder switch
MN3E
MN4E
4GA/B
M4GA/B
MN4GA/B
F.R.(module unit)
Clean F.R.
Precision R
Press gauge
Diff. press gauge
Electro-pneumatic R
Speed controller
Auxiliary valve
Fitting/tube
Clean air unit
Pressure sensor
Flow rate sensor
Valve for air blow
Ending

Design & selection

Working fluid

DANGER

■ Do not use this product for flammable fluids.

WARNING

■ This product cannot be used as a billing meter.

Do not use this product for commercial transactions as it is not compliant with the Measurement Act.

Intended applications include industrial sensors.

■ Do not use fluids other than the applicable fluid because accuracy cannot be guaranteed.

■ When using compressed air, use clean air that complies to JIS B 8392-1: 2012 Class [1:1:1 to 1:6:2]. Compressed air from the compressor contains drainage (water, oil oxide, foreign matters, etc.). So install a filter, air dryer, and oil mist filter (micro alescser) on the primary side (upper stream side) of the sensor. The sensor's meshing rectifies flow in the pipe. It does not filter out foreign matters, so provide a filter.

[Recommended circuit]

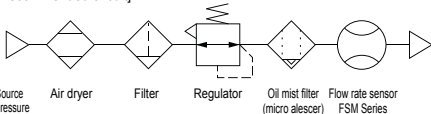

■ When using a valve on the primary side of the sensor, use only a valve with oil-prohibited specifications. This sensor could malfunction or fail if exposed to splattered grease, oil, etc. Friction powder could be generated depending on the valve, so mount a filter to prevent the powder from entering the sensor.

■ When using the valve with liquified gases such as carbon dioxide, always vaporize the gas. Faults could result if the liquified gas enters this product.

■ Use dry gas which does not contain corrosive elements such as chlorine, sulfur or acids, and which is clean and does not contain dust or oil mist.

■ Depending on the fluid, retaining the fluid for a long time could adversely affect the performance. Do not seal the fluid in the pipe for long periods of time.

Working environment

DANGER

■ Flammable environment

Do not use this product in an explosive gas atmosphere. The structure is not explosion-proof, and explosions or fires could occur.

WARNING

■ Corrosive environment

Do not use this product in an atmosphere containing corrosive gases such as sulfur dioxide.

■ Ambient temperature/fluid temperature

Use ambient temperature/fluid temperature from 0 to 50°C within specified range.

Even if the temperature is within the specified range, do not use this product if the ambient temperature and fluid temperature could suddenly change and cause dew to condense.

■ Working pressure/flow rate range

Applications exceeding the max. working pressure, min. working pressure, or specified flow rate range may result in faults. Use this product only within the specified range.

■ Drip-proof environment

This product's degree of protection is IP40 or equivalent. Do not install this product where water, salt, dust, or swarf is present or in a pressurized or depressurized environment.

This product cannot be used where the temperature changes sharply or in a highly humid environment where internal damage could be caused by condensation.

Flow rate unit

CAUTION

■ This product's flow rate is measured at a mass flow rate unaffected by temperature or pressure. The unit is $l/min.$, but this is the display when the mass flow rate is converted to volumetric flow rate at 20°C 1 barometric pressure (101 kPa), and a relative temperature of 65%.

Proof pressure

CAUTION

■ Please note the difference when you select the series.

Overflow

CAUTION

■ With each series, no problem will occur in the sensor, even if an overflow double the measurement range. If dynamic pressure is applied near the max. working pressure (when a pressure difference exceeding the max. working pressure is applied between primary and secondary sides), a problem could occur with the sensor. If dynamic pressure is applied, such as when a workpiece is filled for leakage inspection, provide a bypass circuit or restrictor so that dynamic pressure is not applied to the sensor.

Use for suction confirmation, etc.

⚠ CAUTION

- When this product is used to confirm suction, etc., select the flow rate range based on the operating vacuum pressure and suction nozzle. Refer to "Methods for calculating theoretic flow rate" on page 1073 for details.
- When this product is used to confirm suction, etc., provide an air filter upstream from suction to prevent the entry of foreign matter.
- When this product is used to confirm suction, etc., consider the atmospheric dew point and this product's ambient temperature, and use the product under conditions in which dew does not condense in pipes.
- When this product is used to confirm suction, etc., response time may be delayed by the capacity of the pipe between the vacuum nozzle and this product. In this case, take countermeasures to reduce piping capacity.
- When this product is used for vacuum applications such as air suction, do not bend the tube near the push-in fitting. If stress is applied to the tube near the push-in fitting, insert an insert ring into the tube, and connect the tube to the push-in fitting.

Using for leakage inspections

- The working pressure range of this product is -0.09 to 1.00 MPa. If it is energized in a vacuum state of -0.09 MPa or less, the sensor's heat dissipation performance will drop and could degrade the sensor.
- When the suction confirmation sensor is switched from a pressure sensor (switch) to a flow rate sensor (switch), sensor output (switch output) logic will be reversed. Refer to the drawing below. Note that the PLC sequence program must be changed or revised.

If source pressure or vacuum source is not supplied when device power is turned on, "flow rate 0" = "sensor output (switch output) ON" status is set at the flow rate sensor (switch). Check that this is not a problem with the PLC sequence program, etc.

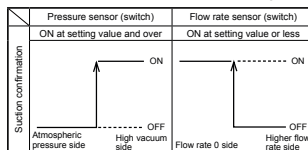

Installation & adjustment

Piping

⚠ CAUTION

- Always attach the pipes before starting wiring.
- Align the fluid flow direction to the direction indicated on the pipe when connecting the pipes.
- When installing the sensor on piping, refer to the torque below so that excessive screw-in torque or load torque is not applied to the connection port.

(Reference value)

Port thread	Tightening torque N·m
M5	1.0 to 1.5
Rc1/8 (G1/8)	3 to 5
Rc1/4	6 to 8
Rc1/2	16 to 18

- Before piping, clean out the pipes using air blower to remove all foreign matter and cutting chips from the pipes. The rectifier or sensor chip could be damaged if an entry of a large amount of foreign matter, cutting chips, etc., occurs.
- Attach a wrench to metal sections when tightening pipes so that pressure is not applied to the resin section.

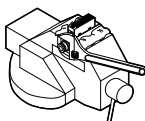

- Check that sealant tape or sealant material does not get inside during piping.* When using for clean room specifications, make sure that the sealant material matches the system.

When winding fluoro resin sealing tape around threads, wind sealing tape once or twice, leaving two to three threads open at the end of the screw. Press the sealing tape with your fingertip so that it sticks closely to the threads. When using liquid sealant, leave one to two threads open from the end, and avoid applying too much. Check that the sealant does not get on device threads.

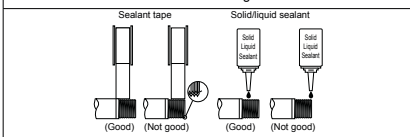

- Connect a fitting even when using the metal body with the OUT side opened. The port filter could come off.
- When using a push-in fitting, accurately insert tube and confirm that it is not dislocated even when pulled. Cut the tube at a right angle with a dedicated cutter before use.
- Make sure that the leakage detection solution does not enter the case when inspecting the pipe for leaks.
- Do not install the regulator/solenoid valve, etc., immediately before this product. Incorrect flow could cause errors. Provide a straight piping section if required.
- Although the mounting is "unrestricted in vertical/horizontal direction", the flow rate may vary depending on difference in the mounting orientations or piping conditions.

About Mounting

⚠ CAUTION

- The display integrated flow rate meter uses a liquid crystal display, which may be difficult to read depending on the angle.
- Do not install the product in a manner that the bodies contact each other. The generation of heat from each other could cause the product body's temperature rise and enhance the change in characteristics or the deterioration of the resin materials. When using the products in a row, set intervals of distance of 10 mm and over.

- SCPD3
- SCM
- MDC2
- SMG
- SSD2
- STM
- STG
- LCR
- LCG
- LCX
- LCM
- STR2
- MRL2
- GRC
- Cylinder switch
- MN3E
- MN4E
- 4GA/B
- M4GA/B
- MN4GA/B
- F.R.(module unit)
- Clean F.R.
- Precision R
- Press.gauge
- Diff.press.gauge
- Electro-pneumatic R
- Speed controller
- Auxiliary valve
- Fitting/tube
- Clean air unit
- Pressure sensor
- Flow rate sensor
- Valve for air blow
- Ending

Installation & adjustment

- This product can be installed in any direction; top, bottom, left, or right.

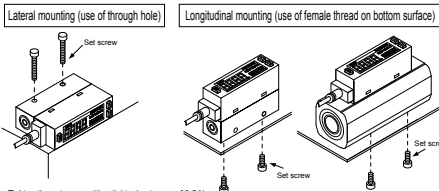

Tighten the set screw with a tightening torque of 0.5 N·m.
Bracket mounting (use of dedicated bracket)

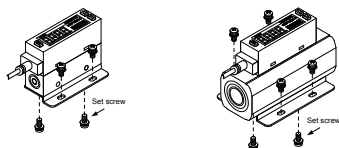

Port size: Push-in $\phi 4$, $\phi 6$, $\phi 8$, $\phi 10$ Port size: Rc1/2
Rc1/8, Rc1/4, M5 Bracket model No. FSM2-LB2

Bracket model No. FSM2-LB1
Tighten the set screw with a tightening torque of 0.5 N·m.

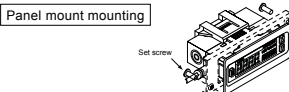

Panel mount mounting
Tighten the set screw with a tightening torque of 0.06 N·m.
Complete the piping before assembly.
If the pipes are connected after assembly, excessive stress will be applied and may damage the product.
When mounting panels, make sure that vibration is not applied on the product. When using on a stainless steel body, the vibration will be amplified and could damage the product.

- Check that stress (7 N and over) is not directly applied to cable lead outs or connectors.
- Stop the control device and equipment and turn power off before wiring. Starting operation suddenly could cause unpredictable operation and hazards. Conduct an energized test with controls and machine devices stopped, and set target switch data. Be sure to discharge any accumulated electrostatic charge among personnel or tools before and during work. Connect and wire bending resistant material, such as robot wire material for movable sections.
- Do not use this product at levels exceeding the power supply voltage range. If voltage exceeding this range is applied or if AC power is applied, the controller could rupture or burn.
- Install this product and wiring far away from sources of noise, such as power distribution wires. Provide separate countermeasures for surge applied to the power cable. The display or output could fluctuate.
- Do not short-circuit the load. Failure to observe this could result in rupture or burning.
- The power supply for the metal body (stainless steel body, aluminum body) is a DC stabilized power supply completely isolated from the AC primary side. Connect either the + side or - side of the power to F.G. A variable resistor (voltage limit approx. 40 V) is connected between the metal body internal power circuit and metal body to prevent dielectric breakdown of the sensor. Do not conduct a withstand voltage test or insulation resistance test between the internal power circuit and metal body. Disconnect wiring if this testing is required. An excessive potential difference between power and metal body will burn internal parts. After installing, connecting and wiring the metal body, electrical welding of the device/frame, or short-circuit accidents, etc., could cause welding current, excessive high voltage caused by welding, or surge voltage, etc., to run through wiring, ground wire, or fluid path connected between such devices, damaging wires or devices. Conduct any work such as electrical welding after removing this device and disconnecting all electric wires connected to the F.G.

- Connecting load
The output impedance of the analog output section is approx. 1 k Ω . If the impedance of the connecting load is small, output error increases. Check error with the impedance of the connecting load before using. (The analog output current output is excluded.)

Example of calculation

$$\begin{aligned} \text{FSM2-}^{\ast}\text{V output impedance: } R_o &= 1 \text{ k}\Omega \\ \text{Load internal impedance: } R_x &= 1 \text{ M}\Omega \\ \text{Output value} &= \left(1 - \frac{R_o}{R_o + R_x}\right) \times 100\% \\ &= \left(1 - \frac{1 \text{ k}\Omega}{1 \text{ k}\Omega + 1 \text{ M}\Omega}\right) \times 100\% \Rightarrow \text{Error in the output value approx. 0.1\%} \end{aligned}$$

During adjustment

- **CAUTION**
If switches are operated when flow rate is not stable, such as pulsating, operation may be unstable. In this case, provide sufficient margin between the two setting values and avoid setting switches in an unstable area. Confirm that switch operation is stable before use.

About Wiring

DANGER

- Use power supply voltage and output within the specified voltage. If voltage exceeding the specified voltage is applied, the sensor could malfunction or be damaged, or electrical shock or fire could occur. Do not use any load that exceeds the rated output. Failure to observe this could result in output damage or fire.

WARNING

- Check line color when wiring. Incorrect wiring could result in sensor damage and malfunctions, so check wire color against the instruction manual before wiring.
- Check wiring insulation. Check that wires do not contact other circuits, that no ground faults occur, and that the insulator between terminals is not defective. Overcurrent could flow in and damage the sensor.
- Use a stabilized DC power supply within the specified rating that has been insulated from the AC power supply. A noninsulated power supply could result in electrical shock. If power is not stabilized, the peak value could be exceeded. This could damage the product or impair accuracy.
- Always attach the connector bar after connecting the connector.

SCPD3
SCM
MDC2
SMG
SSD2
STM
STG
LCR
LCG
LCX
LCM
STR2
MRL2
GRC
Cylinder switch
MN3E
MN4E
4GA/B
M4GA/B
MN4GA/B
F.R.(module unit)
Clean F.R.
Precision R
Press gauge
Diff. press gauge
Electro-pneumatic R
Speed controller
Auxiliary valve
Fitting/tube
Clean air unit
Pressure sensor
Flow rate sensor
Valve for air blow
Ending

During use & maintenance

⚠ WARNING

- Output accuracy is affected by temperature characteristics and self-heat generated when energized. Provide standby time (5 minutes and over) after turning power ON before using.
- Immediately after power is turned ON, this product does not start flow rate detection switch operation for approx. 4 seconds to complete self-diagnosis. Provide a control circuit/program that ignores signals for 4 seconds after energizing.

⚠ CAUTION

- This product uses a micro-sensor chip, and must be installed where it will not be subject to dropping, impact or vibration. Handle this product as a precision component during installation and transportation.
- If a problem occurs during operation, immediately turn power OFF, stop use, and contact your dealer.
- Keep this product's flow rate within the rated flow range.
- Use this product within the working pressure range.
- If the output setting value is changed, control system devices could operate unintentionally. Stop devices before changing settings.
- Do not disassemble or modify this product. Doing so could result in faults.
- The case is made of resin. Do not use solvent, alcohol or detergent in cleaning, or resin could absorb it. There is a risk of affecting the resin. Wipe off dirt with a rag soaked in a diluted neutral detergent solution and wrung out well.
- Pay attention to reverse currents caused by disconnected wires and wiring resistance. If other devices, including a flow rate sensor, are connected to the same power supply as the flow sensor, and the switch output wire and power cable minus (-) side are short-circuited to check the operation of the control panel's input unit, or if the power cable's minus (-) side is disconnected, back current could flow to the flow rate sensor's switch output circuit and cause damage.

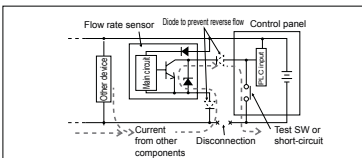

- Take countermeasures as followings to prevent damages caused by reverse current.
 - (1) Avoid centralizing current at the power cable, especially the minus side power cable, and use as thick a cable as possible.
 - (2) Limit the number of devices connected to the same power supply as the flow rate sensor.
 - (3) Insert a diode parallel to the flow rate sensor's output line to prevent the reverse current.
 - (4) Insert a diode parallel to the flow rate sensor power wire's minus (-) side to prevent the reverse current.
- Care must be taken for surge current leading. When flow rate sensor power is shared with an inductive load that generates surges, such as a solenoid valve or relay, if the circuit is cut off while the inductive load is functioning, surge current could enter the switch output circuit and cause damage depending on where the surge absorbing element is installed.

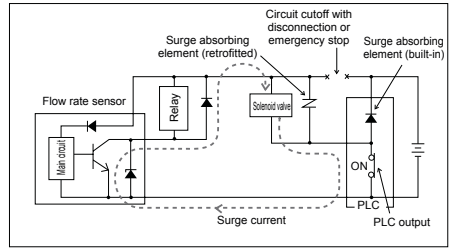

Take the following countermeasures as followings to prevent damages caused by reverse current.

- (1) Separate the power supply for output including the inductive load, such as the solenoid valve and relay, and input, such as the flow rate sensor.
- (2) If separate power supplies cannot be used, directly install a surge absorption element for all inductive loads. Remember that the surge absorbing element connected to the PLC, etc. protects only that device.
- (3) Connect a surge absorption element to the following places on the power wiring as shown below as a measure against disconnections in unspecific areas.

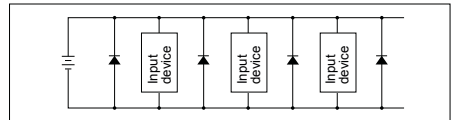

When the devices are connected to a connector, the output circuit could be damaged by the above phenomenon if the connector is disconnected while the power is ON. Turn the power OFF before connecting or disconnecting the connector.

- Analog output continues even if the flow rate range is exceeded. With the display integrated, "Hi" or "Lo" will be displayed. With the display separated, the bar display will flicker. Note that this is outside guaranteed precision.
- When using the display integrated, do not press down on the display section. It could break.
- The accuracy may vary from the initial status depending on the working environment or working conditions at the customer site. It is recommended to check the operation of the product periodically.
- The sensor chip will degrade when used for a long time and cause the detected flow rate to vary. Periodically inspect the sensor chip.
- CE-compliance working conditions

This product is CE-marked, indicating conformity with the EMC Directives. The standard for the immunity for industrial environments applied to this product is EN61000-6-2; the following requirements must be satisfied in order to conform to this standard: Conditions

 - The assessment of this product is performed by using a cable pairing a power supply line and a signal line, treating this cable as a signal line.
 - This product is not equipped with surge immunity. Implement surge protection measures on the system side.

SCPD3
SCM
MDC2
SMG
SSD2
STM
STG
LCR
LCG
LCX
LCM
STR2
MRL2
GRC
Cylinder switch
MN3E MN4E
4GA/B
M4GA/B
MN4GA/B
F.R.(module unit)
Clean F.R.
Precision R
Press.gauge Diff.press.gauge
Electro-pneumatic R
Speed controller
Auxiliary valve
Fitting/tube
Clean air unit
Pressure sensor
Flow rate sensor
Valve for air blow
Ending

SCPD3
SCM
MDC2
SMG
SSD2
STM
STG
LCR
LCG
LCX
LCM
STR2
MRL2
GRC
Cylinder switch
MN3E MN4E
4GA/B
M4GA/B
MN4GA/B
F.R. (module unit)
Clean F.R.
Precision R
Press gauge Diff. press gauge
Electro-pneumatic R
Speed controller
Auxiliary valve
Fitting/ tube
Clean air unit
Pressure sensor
Flow rate sensor
Valve for air blow
Ending

Needle valve integrated FSM2-*N Series

Design & selection

CAUTION

■ This valve cannot be used as a stop valve that has no leakage. Slight leakage is allowed in product specifications.

■ The flow path in the needle valve is not completely free of dust generation. A final clean filter should be used in circuits where dust generation could be a problem.

Installation & adjustment

CAUTION

■ Do not turn the dial forcibly when fully closing or opening it (0.05 N·m or less). Do not use the lock nut to adjust the needle. Otherwise this could cause needle galling or damage.

■ The set flow rate may vary if turning the dial of the needle valve forcibly when fully closing. Take care not to turn the dial forcibly when setting a very small flow rate.

During use & maintenance

CAUTION

■ Vibration could cause the needle to turn and the flow rate to change.

Separate indicator FSM2-D Series

Design & selection

CAUTION

- The voltage output (1-5 V) sensor is supported. If the current output type or other voltage output type is connected, it won't operate properly. Use FSM2-AV* when using FSM2.

Installation & adjustment

CAUTION

- Cut the half strip section at the end of the e-con connector wiring before using. Insert the wire to the back of the connector, and securely crimp with pliers, etc. The wire sheath does not need to be removed. Check that the pin No. and wire color are correct before crimping. Incorrect wiring can lead to sensor or separated indicator damage, faults or malfunction.

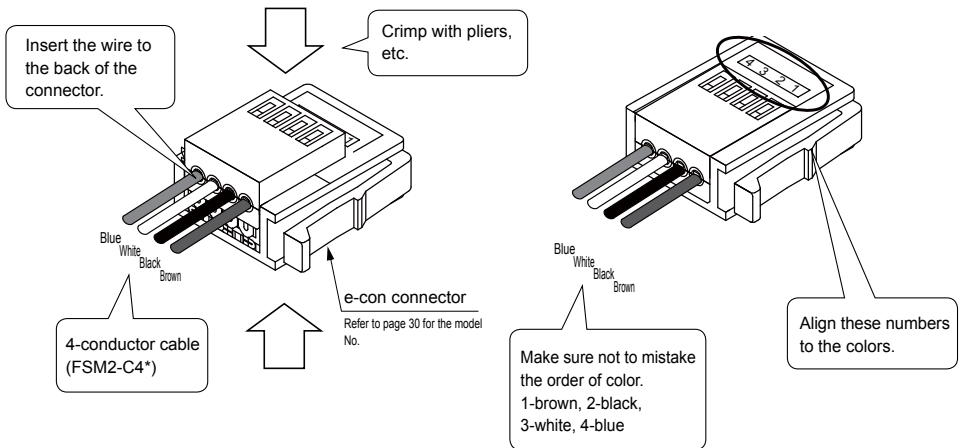

- When attaching or removing the cable, hold the connector instead of the cable. Holding the cable could result in a contact fault, broken wire or short-circuit, etc., could damage the sensor or separated indicator, or cause malfunctions.
- Do not apply a load of 15 N and over onto the cable.

SCPD3
SCM
MDC2
SMG
SSD2
STM
STG
LCR
LCG
LCX
LCM
STR2
MRL2
GRC
Cylinder switch
MN3E MN4E
4GA/B
M4GA/B
MN4GA/B
F.R.(module unit)
Clean F.R.
Precision R
Press.gauge Diff.press.gauge
Electro-pneumatic R
Speed controller
Auxiliary valve
Fitting/tube
Clean air unit
Pressure sensor
Flow rate sensor
Valve for air blow
Ending