



Air filter

F2000/F3000/F4000/F6000 Series

JIS symbol



Structure/treatment and material restriction

	Structure/treatment	Material restriction			Model No.
P7 Series	Dust generation preventing				— P70
	Dust generation preventing	Copper-based materials prohibited	Silicon-based materials prohibited	Halogen-based materials prohibited (fluorine, chlorine, bromine)	— P74 Custom order product

Specifications

Descriptions	F2000	F3000	F4000	F6000
Working fluid	Compressed air			
Max. working pressure MPa	1.0			
Proof pressure MPa	1.5			
Ambient temperature/fluid temperature °C	5 to 50			
Filtration rating μm	5	5 or 0.3		
Weight kg	0.24	0.25	0.45	0.90

How to order



A Model No.	Model No.			
	F2000	F3000	F4000	F6000

Code	Content	F2000	F3000	F4000	F6000
B Port size					
8	Rc1/4	●	●	●	●
10	Rc3/8	●	●	●	●
15	Rc1/2			●	
20	Rc3/4				●
25	Rc1				●

		*1 *2		F2000	F3000	F4000	F6000
Bowl	Blank	PC bowl: without drain discharge		●	●	●	●
	C6	PC bowl: drain discharge Rc1/8		●	●	●	●
	M6	Metal bowl: drain discharge Rc1/8		●	●	●	●
Element	Blank	5 μm		●	●	●	●
	Y	0.3 μm (submicron)			●	●	●
Differential pressure detection	Blank	Without differential pressure detection port		●	●	●	●
	Q	With differential pressure detection port (Rc1/4)					●
Flow direction	Blank	Standard flow (left → right)		●	●	●	●
	X1	Reverse flow (right → left)		●	●	●	●

⚠ Precautions for model No. selection

- *1: Select options per drainage, bowl material, element, and differential pressure detection sections. When selecting options for several sections. When selecting options for several items, list options in order from the top.
- *2: One pipe plug is attached for options "C6" and "M6".
- *3: Piping adaptor set A *00*-P70 (page 804) is attached.
- *4: Refer to pages 804 to 806 for adaptor. The piping adaptor set and C bracket cannot be used at the same time.
- *5: Refer to page 781 for max. processing flow when option "Y" is selected.
- *6: "P74" is custom order.

D Clean room specifications

	Structure/treatment	Material restriction	F2000	F3000	F4000	F6000
P70	Dust generation preventing	-	●	●	●	●
P74	Dust generation preventing	Copper-based/silicon-based/halogen-based materials (fluorine, chlorine, bromine) are prohibited	●	●	●	●

E Other attachments

	Blank	Without attachment	F2000	F3000	F4000	F6000
A8	Rc1/4 piping adaptor set		●	●	●	●
A10	Rc3/8 piping adaptor set		●	●	●	●
A15	Rc1/2 piping adaptor set		●	●	●	●
A20	Rc3/4 piping adaptor set				●	●
A25	Rc1 piping adaptor set					●
A32	Rc1 1/4 piping adaptor set					●
B	C bracket		●	●	●	●

Flow characteristics

● F2000-8

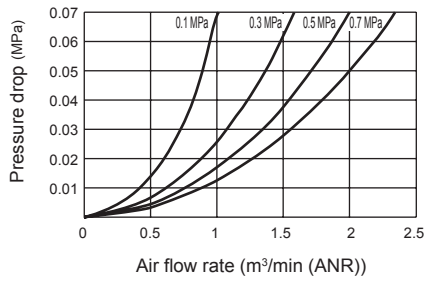

● F2000-10

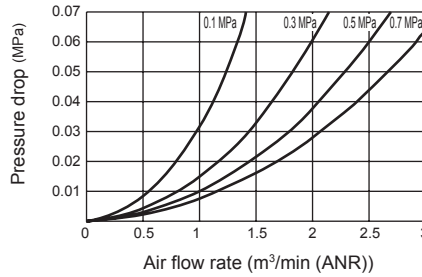

● F3000-8

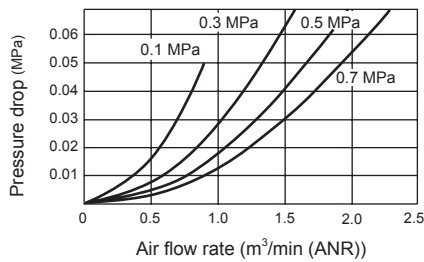

● F3000-10

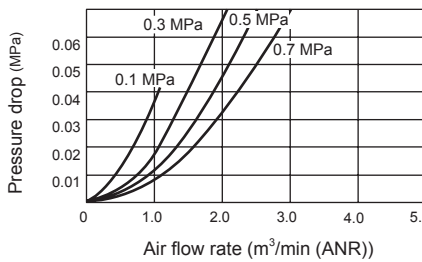

● F4000-8

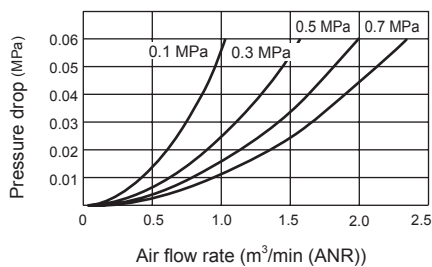

● F4000-10

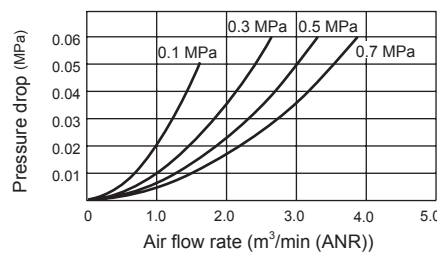

● F4000-15

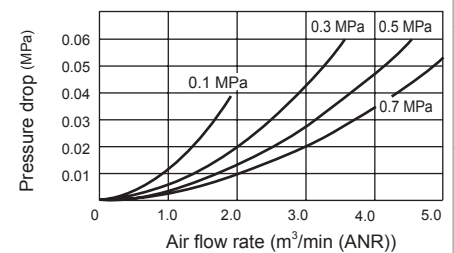

● F6000-20

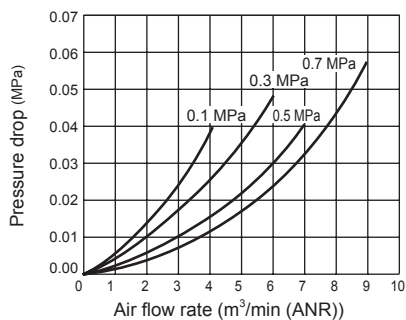

● F6000-25

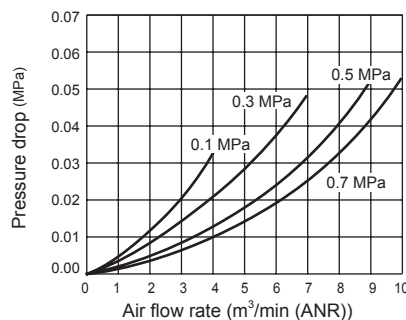

● F3000
F4000-*-Y (0.3 μm element)
F6000

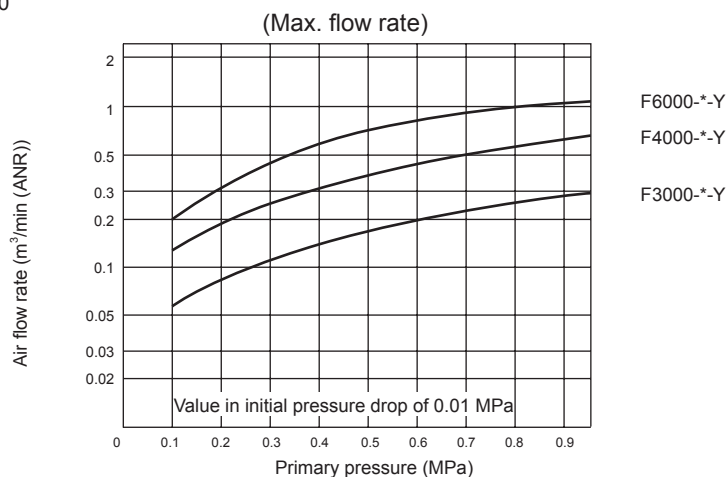

SCPD3

SCM

SSD2

MDC2

SMG

LCM

LCR

LCG

LCX

STM

STG

STR2

MRL2

GRC

Cylinder Switch

MN3E

MN4E

4GA/B

M4GA/B

MN4GA/B

F.R. (module unit)

Clean F.R

Precision R

Press gauge
Diff. press gauge

Electro-pneumatic R

Speed controller

Auxiliary valve

Fitting/tube

Clean air unit

Pressure sensor

Flow rate sensor

Valve for air blow

Ending

Air Filter Series

Dimensions

● F2000-P70/P74

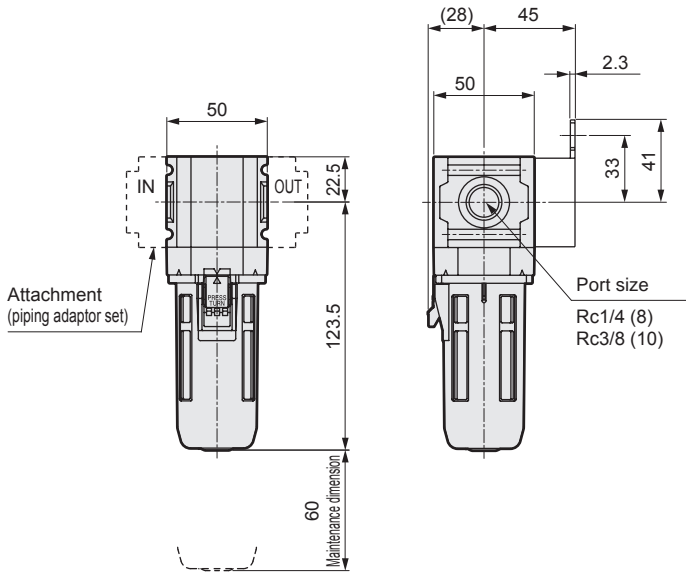

Note : C bracket and piping adaptor set attachments cannot be used at the same time.

● F3000-P70/P74

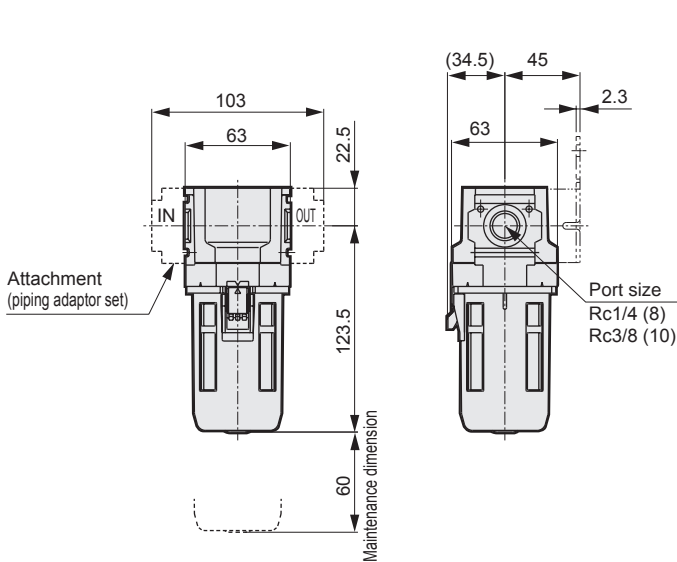

Note : C bracket and piping adaptor set attachments cannot be used at the same time.

[Optional dimensions]

● PC bowl drain discharge Rc1/8 (C6)

● Metal bowl (M6)

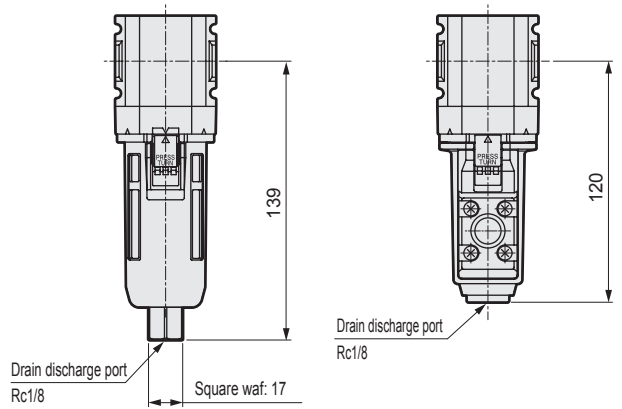

Note: Mount with fixing on square waf, when pipe for drain discharge.

[C bracket dimensions]

● Part model No.: B220-P70

· Material: steel, nickel plate processing

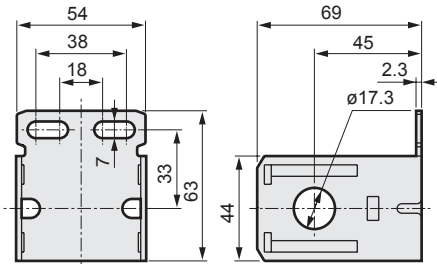

[Optional dimensions]

● PC bowl drain discharge Rc1/8 (C6)

● Metal bowl (M6)

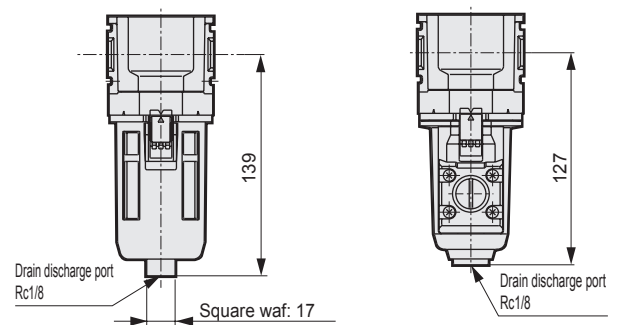

Note: Mount with fixing on square waf, when pipe for drain discharge.

[C bracket dimensions]

● Part model No.: B320-P70

· Material: steel, nickel plate processing

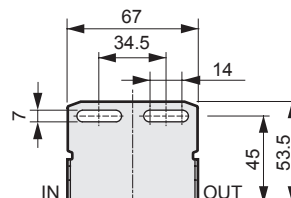

Dimensions

● F4000-P70/P74

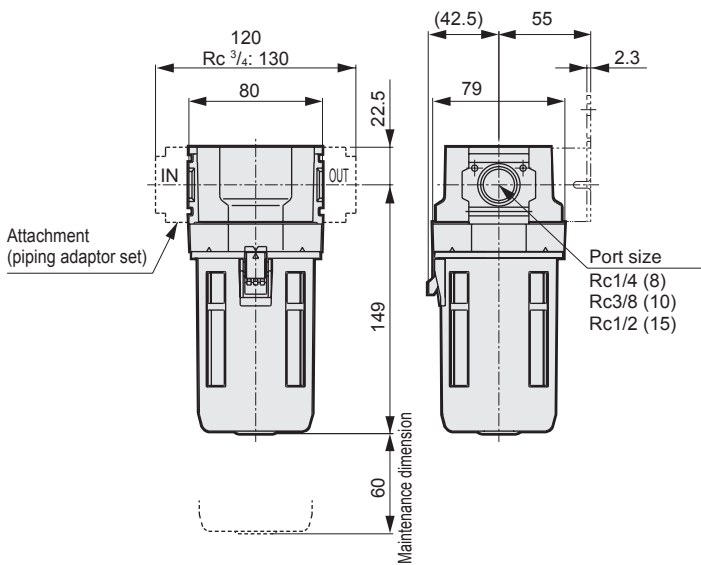

Note : C bracket and piping adaptor set attachments cannot be used at the same time.

● F6000-P70/P74

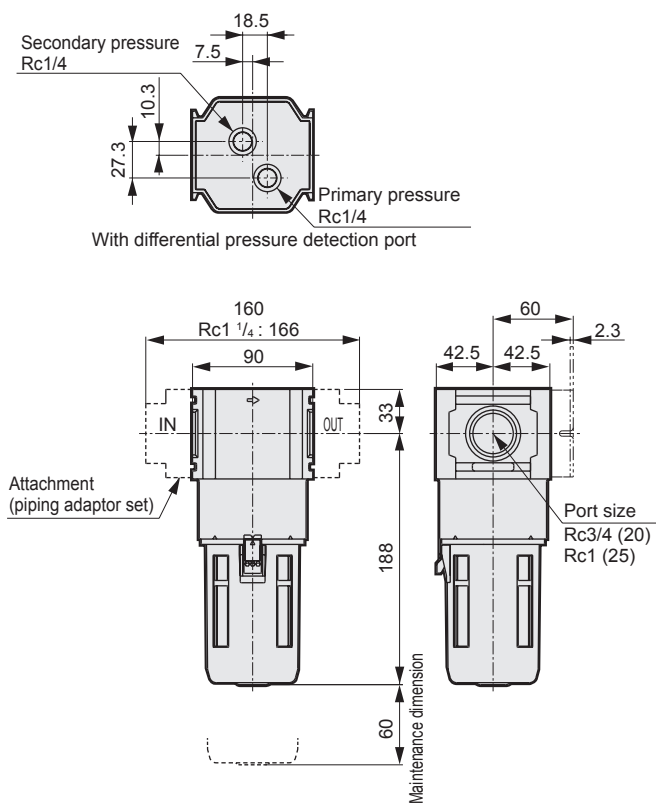

Note : C bracket and piping adaptor set attachments cannot be used at the same time.

[Optional dimensions]

● PC bowl drain discharge Rc1/8 (C6)

● Metal bowl (M6)

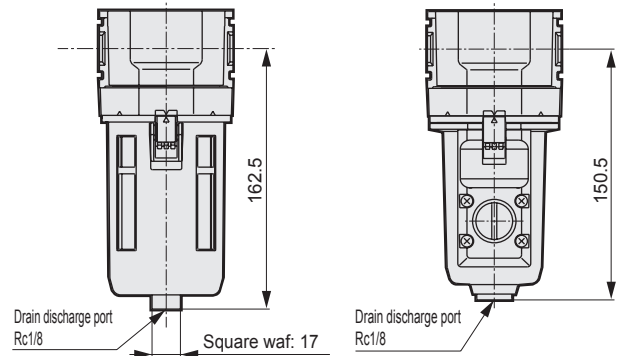

Note: Mount with fixing on square waf, when pipe for drain discharge.

[C bracket dimensions]

● Part model No.: B420-P70

· Material: steel, nickel plate processing

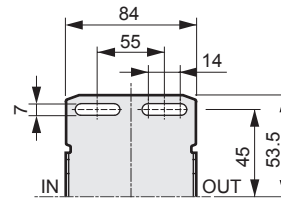

[Optional dimensions]

● PC bowl drain discharge Rc1/8 (C6)

● Metal bowl (M6)

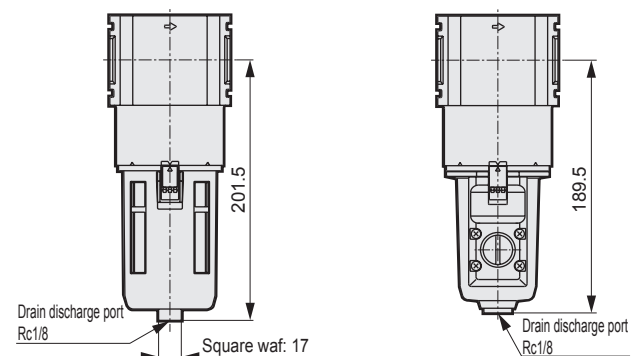

Note: Mount with fixing on square waf, when pipe for drain discharge.

[C bracket dimensions]

● Part model No.: B620-P70

· Material: steel, nickel plate processing

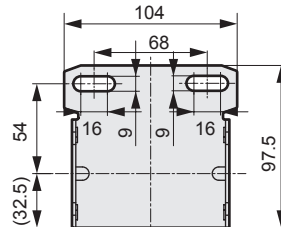

SCPD3
SCM
SSD2
MDC2
SMG
LCM
LCR
LCG
LCX
STM
STG
STR2
MRL2
GRC
Cylinder Switch
MN3E MN4E
4GA/B
M4GA/B
MN4GA/B
F.R.(module unit)
Clean F.R
Precision R
Press gauge Diff. press gauge
Electro-pneumatic R
Speed controller
Auxiliary valve
Fitting/tube
Clean air unit
Pressure sensor
Flow rate sensor
Valve for air blow
Ending