

SHC

High power cylinder

ø40/ø50/ø63/ø80/ø100

Special

Overview

High power cylinder is an ultra energy saving cylinder developed for applications where high power is required at the stroke end. Compared to conventional types, this cylinder is far superior in terms of operation costs, space and environmental friendliness, making it well suited to the next generation factory lines and equipment.

Features

Ultra energy saving realized

Air consumption volume is approximately 1/2 to 1/8 (compared to conventional).

The conventional ø100 is reduced to ø50.

Power equivalent to conventional cylinders is realized with a cylinder bore size of less than half. (Quad force)

Drastically reduced footprint

Conventionally, the same amount of power is obtained with a cylinder bore size one to two sizes larger.

This offers a superior advantage when installing in a narrow space.



CONTENTS

Product introduction and application examples	1138
Series variation	1142
● Double acting/double force (SHC)	1144
● Double acting/quad force (SHC-K)	1154
SHC Series common option/accessory dimensions	1162
Technical data	1165
⚠ Safety precautions	1172

LCM
LCR
LCG
LCW
LCX
STM
STG
STS/STL
STR2
UCA2
ULK*
JSK/M2
JSG
JSC3/JSC4
USSD
UFCD
USC
UB
JSB3
LMB
LML
HCM
HCA
LBC
CAC4
UCAC2
CAC-N
UCAC-N
RCS2
RCC2
PCC
SHC
MCP
GLC
MFC
BBS
RRC
GRC
RV3*
NHS
HRL
LN
Hand
Chuk
MechHnd/Chuk
ShkAbs
FJ
FK
SpdContr
Ending

Cylinders are changing.

High power cylinders that promise higher profits at production sites.

This high power cylinder is an ultra energy saving cylinder developed for applications where high power is required at the stroke end. Compared to conventional types, this cylinder is far superior in terms of operation costs, space and environmental friendliness, making it well suited for the next generation factory lines and equipment.

■ Ultra energy saving realized

Air consumption volume is approximately 1/2 to 1/8 (compared to conventional).

■ The conventional $\varnothing 100$ is reduced to $\varnothing 50$.

Power equivalent to conventional cylinders is realized with a cylinder bore size of less than half. (Quad force)

■ Drastically reduced footprint

The same amount of power is conventionally obtained with a cylinder bore size one to two sizes larger. This offers a superior advantage when installing in a narrow space.

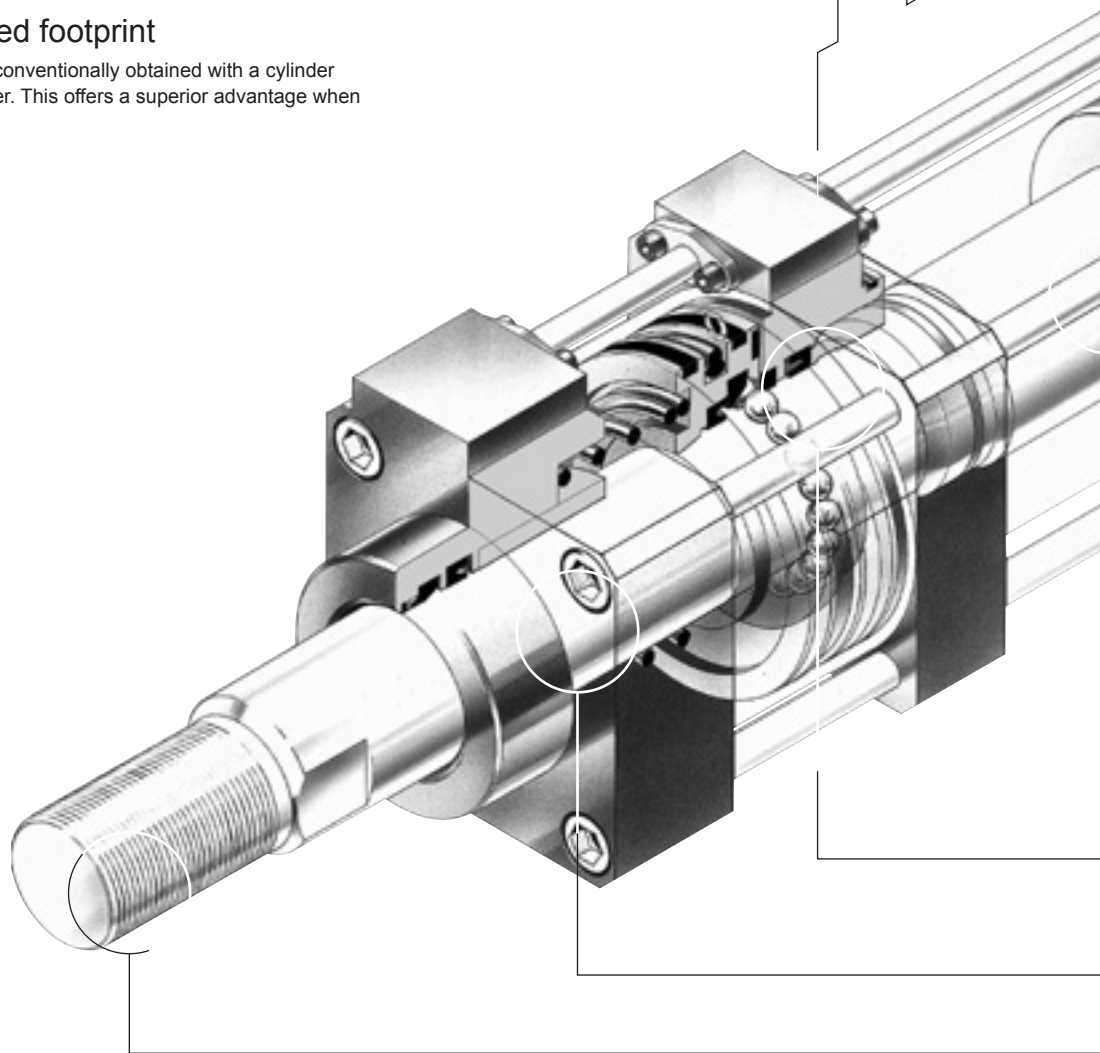
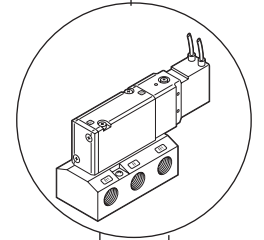

LCM
LCR
LCC
LCW
LCX
STM
STG
STS/STL
STR2
UCA2
ULK*
JSK/M2
JSG
JSC3/JSC4
USSD
UFCD
USC
UB
JSB3
LMB
LML
HCM
HCA
LBC
CAC4
UCAC2
CAC-N
UCAC-N
RCS2
RCC2
PCC
SHC
MCP
GLC
MFC
BBS
RRC
GRC
RV3*
NHS
HRL
LN
Hand
Chuk
MecHnd/Chuk
ShkAbs
FJ
FK
SpdContr
Ending

● Piping is the same as conventional

The piping is the same as the conventional cylinder driven by a 4-way valve. Direct replacement of the current cylinder is possible. For general use, the piping is the same as the conventional cylinder as the air is supplied to the booster cylinder by pass-pipe.

● Air consumption is significantly reduced

As most of the cylinder stroke has a small-bore cylinder mechanism with low thrust, air consumption can be greatly reduced.

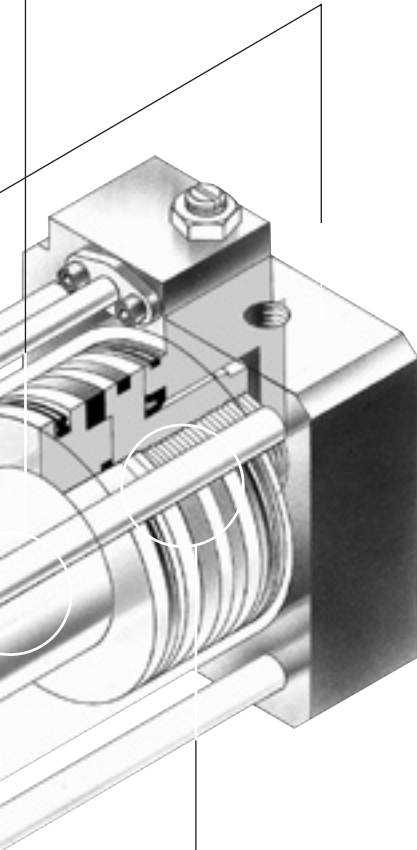

● Easy switch mounting

Position detecting switch can be easily attached. (Option)

● Saves space significantly

Compared to conventional products, the double force cylinder diameter is reduced to 60% of the original and the quad force volume is reduced to 25%, realizing dramatic space savings.

● Wide range of mounting

Extensive mounting types are available, such as foot and flange.

● Available in $\varnothing 40$ to $\varnothing 100$ to cover the maximum end power of $\varnothing 200$ or equivalent

Double and quad force are available

The stroke end has twice as much thrust as the conventional cylinder due to the booster mechanism. For example, the $\varnothing 63$ double is comparable to the conventional $\varnothing 100$ unit and the $\varnothing 63$ quad is comparable to the conventional $\varnothing 125$. (After the booster retreats, the thrust will be about 70% of the theoretical thrust.)

● Operational explanation

● At PUSH

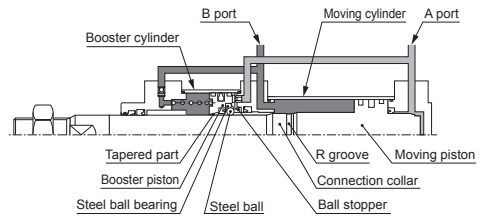

1) The piston rod moves the same way as the normal cylinder, with air supplied from port A and exhausted from port B.

● When linked

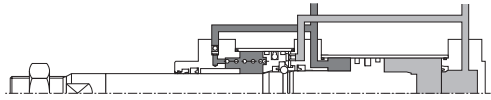

2) When the piston rod moves, the linking collar enters the booster piston. When it reaches the booster piston taper, the booster piston moves, causing the steel ball to fit into the R groove due to the elasticity of the steel ball bearing. This causes the booster piston and connecting collar to connect and form a booster cylinder.

● When boosting

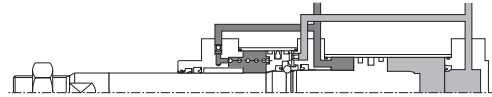

3) By connecting, the united pressure receiving area of the moving piston and booster piston transmits the thrust to the piston rod.

● During PULL Booster backward

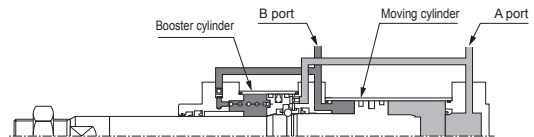

4) When the piston rod is retracted by the air supplied from port A and exhausted from B port, the booster cylinder transmits thrust in the united pressure receiving area of the moving piston and booster piston.

● When uncoupled

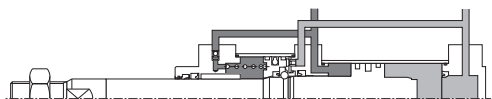

5) Using the ball stopper, push out the steel ball from R groove in the direction of the steel ball bearing before the booster piston is fully retracted to release the connection and retract the piston rod to the stroke end.

LCM
LCR
LCG
LCW
LCX
STM
STG
STS/STL
STR2
UCA2
ULK*
JSK/M2
JSG
JSC3/JSC4
USSD
UFCD
USC
UB
JSB3
LMB
LML
HCM
HCA
LBC
CAC4
UCAC2
CAC-N
UCAC-N
RCS2
RCC2
PCC
SHC
MCP
GLC
MFC
BBS
RRC
GRC
RV3*
NHS
HRL
LN
Hand
Chuk
MechHnd/Chuk
ShkAbs
FJ
FK
SpdContr
Ending

The difference in cost becomes clearer the more you use it.

DATA
Various comparison data with the conventional cylinder

- LCM
- LCR
- LCC
- LCW
- LCX
- STM
- STG
- STS/STL
- STR2
- UCA2
- ULK*
- JSK/M2
- JSG
- JSC3/JSC4
- USSD
- UFCD
- USC
- UB
- JSB3
- LMB
- LML
- HCM
- HCA
- LBC
- CAC4
- UCAC2
- CAC-N
- UCAC-N
- RCS2
- RCC2
- PCC
- SHC
- MCP
- GLC
- MFC
- BBS
- RRC
- GRC
- RV3*
- NHS
- HRL
- LN
- Hand
- Chuk
- MecHnd/Chuk
- ShkAbs
- FJ
- FK
- SpdContr
- Ending

Weight

● Unit kg

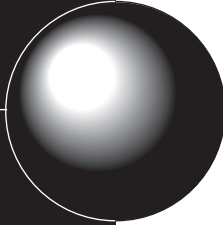
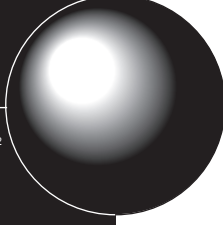
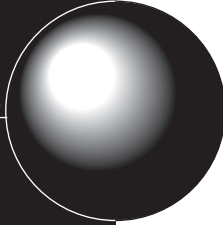
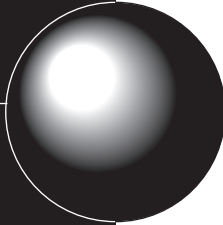

Air consumption

(reciprocating 100 million times)

● Converted to atmospheric pressure at 0.5 MPa

Operation costs

● Calculate the cost by the compressed air cost of 8 JPY/m²

Total cost

● Total cost at 1 million reciprocations

● Conventional

SHC

● Double force

SHC-K

● Quad force

ø100 x 300 stroke
Theoretical thrust: 3927 N
[0.5 MPa]

ø63 x 300 stroke
Theoretical thrust: 3139 N
[0.5 MPa]

ø50 x 300 stroke
Theoretical thrust: 4507 N
[0.5 MPa]

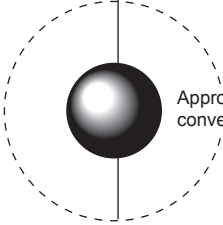
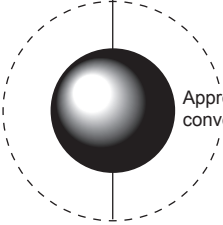
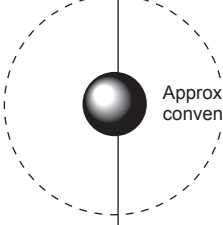
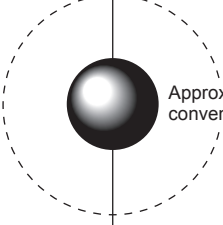
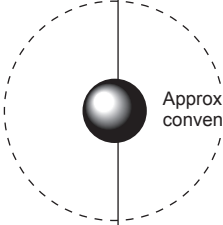
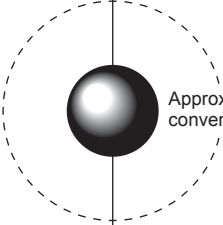
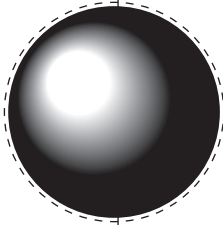
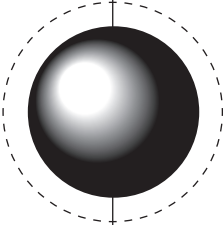

Space

● Unit: mm

● Conventional (ø100 I.D. type)

SHC

● Double force (ø63 I.D. type)

SHC-K

● Quad force (ø50 I.D. type)

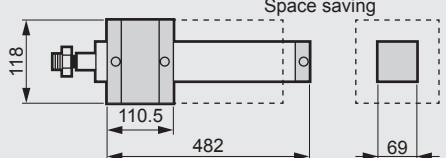
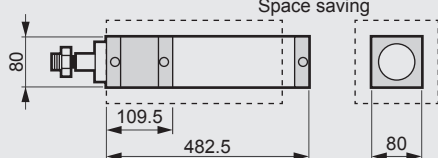
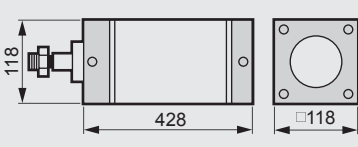

Superior functionality and various applications.

■ Booster single control of high power cylinder

Using booster single control (option code A) realizes a high cycle that conventional cylinders could not achieve.

In most cases, for high frequency cylinder reciprocating operations such as welding gun lines, etc., the tact time is determined by the cylinder's reciprocating time. Even in this case, high-cycle use of the high power cylinder is possible as in the figure below: first reaching out with travel stroke, then stopping for 0.1 sec. and reciprocating several times with booster stroke alone. It can also significantly reduce the stroke reciprocation time, improving the productivity and energy efficiency.

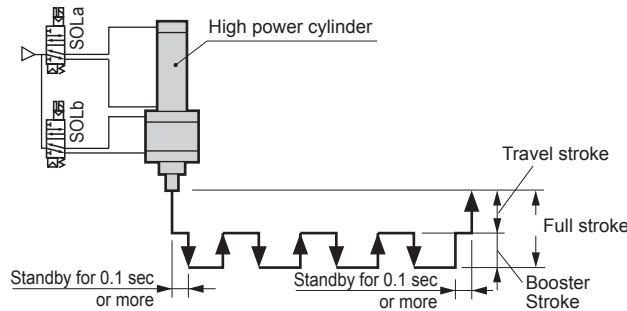

● Welding gun

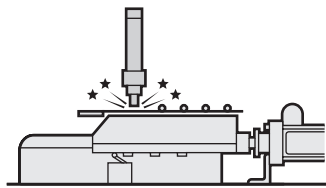

● Engraved mark

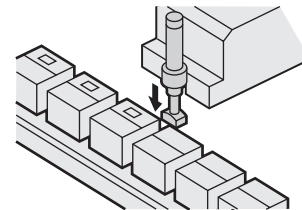

● Clamp 1

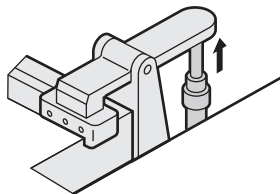

● Press-fit/insert

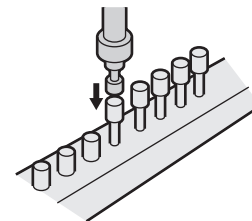

● Clamp 2

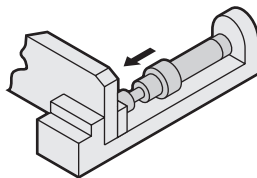

● Crimping

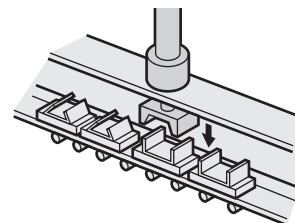



LCM
LCR
LCG
LCW
LCX
STM
STG
STS/STL
STR2
UCA2
ULK*
JSK/M2
JSG
JSC3/JSC4
USSD
UFCD
USC
UB
JSB3
LMB
LML
HCM
HCA
LBC
CAC4
UCAC2
CAC-N
UCAC-N
RCS2
RCC2
PCC
SHC
MCP
GLC
MFC
BBS
RRC
GRC
RV3*
NHS
HRL
LN
Hand
Chuk
MechHnd/Chuk
ShkAbs
FJ
FK
SpdContr
Ending

Series variation

High power cylinder SHC Series

- LCM
- LCR
- LCG
- LCW
- LCX
- STM
- STG
- STS/STL
- STR2
- UCA2
- ULK*
- JSK/M2
- JSG
- JSC3/JSC4
- USSD
- UFCD
- USC
- UB
- JSB3
- LMB
- LML
- HCM
- HCA
- LBC
- CAC4
- UCAC2
- CAC-N
- UCAC-N
- RCS2
- RCC2
- PCC
- SHC**
- MCP
- GLC
- MFC
- BBS
- RRC
- GRC
- RV3*
- NHS
- HRL
- LN
- Hand
- Chuk
- MecHnd/Chuk
- ShkAbs
- FJ
- FK
- SpdContr
- Ending

Variation	Model No. JIS symbol	Bore size (mm)	Standard stroke (mm)												Min. stroke (mm)	Max. stroke (mm)	Custom stroke (per mm)	Booster stroke (mm)				Mounting	
																		Booster stroke (mm)		Basic	Axial foot		
			100	150	200	250	300	350	400	500	600	700	800	900				1000	10			20	00
Double acting/double force 	SHC	ø40/ø50	●	●	●	●	●	●	●	●	●	●	●	●	700	●	●	●	●				
		ø63	●	●	●	●	●	●	●	●	●	●	●	●	800	●	●	●	●				
		ø80	●	●	●	●	●	●	●	●	●	●	●	●	900	●	●	●	●				
		ø100	●	●	●	●	●	●	●	●	●	●	●	●	1000	●	●	●	●				
Double acting/quad force 	SHC-K	ø40/ø50	●	●	●	●	●	●	●	●	●	●	●	700	●	●	●	●					
		ø63	●	●	●	●	●	●	●	●	●	●	●	800	●	●	●	●					
		ø80	●	●	●	●	●	●	●	●	●	●	●	900	●	●	●	●					
		ø100	●	●	●	●	●	●	●	●	●	●	●	1000	●	●	●	●					

●: Standard ○: Option ◯: Made to order, ■: Not available

Mounting							Cushion		Option											Accessory						Switch	Page	
Rod side flange	Head side flange	Eye bracket	Clevis bracket	Intermediate trunnion	Rod side trunnion	Head side trunnion	Without cushion	Head side cushioned	Rod end form male thread	Rod end form flange	Piping port position				Bellows (100°C)	Bellows (250°C)	Metal scraper	Copper and PTFE free	Booster single control port	Rod eye	Rod clevis	Eye bracket (for clevis)	Clevis bracket (for clevis)	Eye bracket (for rod eye)	Clevis bracket (for rod eye/clevis)			
FA	FB	CA	CB	TC	TA	TB	N	H	Blank	F	Blank	R	S	T	J	L	G1	P6	A	I	Y	B11	B21	B12	B22			
●	●	●	●	●	●	●	●	●	○	○	○	○	○	○	○	○	○	○	○	○	○	○	○	○	○	○	○	1144
●	●	●	●	●	●	●	●	●	○	○	○	○	○	○	○	○	○	○	○	○	○	○	○	○	○	○	○	
●	●	●	●	●	●	●	●	●	○	○	○	○	○	○	○	○	○	○	○	○	○	○	○	○	○	○	○	
●	●	●	●	●	●	●	●	●	○	○	○	○	○	○	○	○	○	○	○	○	○	○	○	○	○	○	○	
●	■	■	■	■	●	■	●	●	○	○	○	○	○	○	○	○	○	○	○	○	○	○	○	○	○	○	○	1154
●	■	■	■	■	●	■	●	●	○	○	○	○	○	○	○	○	○	○	○	○	○	○	○	○	○	○	○	
●	■	■	■	■	●	■	●	●	○	○	○	○	○	○	○	○	○	○	○	○	○	○	○	○	○	○	○	
●	■	■	■	■	●	■	●	●	○	○	○	○	○	○	○	○	○	○	○	○	○	○	○	○	○	○	○	

- LCM
- LCR
- LCG
- LCW
- LCX
- STM
- STG
- STS/STL
- STR2
- UCA2
- ULK*
- JSK/M2
- JSG
- JSC3/JSC4
- USSD
- UFCD
- USC
- UB
- JSB3
- LMB
- LML
- HCM
- HCA
- LBC
- CAC4
- UCAC2
- CAC-N
- UCAC-N
- RCS2
- RCC2
- PCC
- SHC**
- MCP
- GLC
- MFC
- BBS
- RRC
- GRC
- RV3*
- NHS
- HRL
- LN
- Hand
- Chuk
- MechHnd/Chuk
- ShkAbs
- FJ
- FK
- SpdContr
- Ending

High power cylinder/double acting/double force

SHC Series

● Equivalent bore size: $\varnothing 40/\varnothing 50/\varnothing 63/\varnothing 80/\varnothing 100$



JIS symbol



Specifications

Item	SHC					
Bore size	mm	$\varnothing 40$	$\varnothing 50$	$\varnothing 63$	$\varnothing 80$	$\varnothing 100$
Actuation	Double acting/projection double force					
Working fluid	Compressed air					
Max. working pressure	MPa	0.9 (≈ 130 psi, 9 bar)				
Min. working pressure	MPa	0.2 (≈ 29 psi, 2 bar)	0.15 (≈ 22 psi, 1.5 bar)			
Proof pressure	MPa	1.35 (≈ 200 psi, 13.5 bar)				
Ambient temperature	$^{\circ}\text{C}$	-10 (14°F) to 60 (140°F) (no freezing)				
Port size	Rc	1/8	1/4	1/4	3/8	3/8
Stroke tolerance	mm	$^{+1.3}_0$ (to 300), $^{+1.7}_0$ (to 1000), $^{+2.1}_0$ (1000 to)				
Working piston speed	Cylinder	50 to 500				
*1	mm/s	40 to 70 (booster section single control)				
Cushion	Air cushion					
Lubrication	Not required (use turbine oil class 1 ISO VG32 if necessary for lubrication)					
Rod side allowable absorbed energy	(J)	12.2	22.9	31.3	47.2	76.2
Head side allowable absorbed energy	(J)	5.84	9.99	15.1	25.5	41.0

*1: As the piston speed differs depending on the supply pressure, refer to the technical data on page 1166.

Stroke

Bore size (mm)	Standard stroke (mm)	Max. stroke (mm)	Booster stroke (mm)	Dead zone
				(mm)
$\varnothing 40$	100, 150, 200, 250, 300, 400, 500	700	10, 20	1.9
$\varnothing 50$				1.9
$\varnothing 63$				2
$\varnothing 80$				2.3
$\varnothing 100$				2.8

*1: The custom stroke is available in 5 mm increments.

*2: Dead zone (area not generating boosted thrust) stroke, until connection with booster piston completes, is included in the booster stroke.

*3: Min. stroke is 40 mm with or without switch. For types with switch, minimum stroke varies depending on mounting method. Refer to the following table.

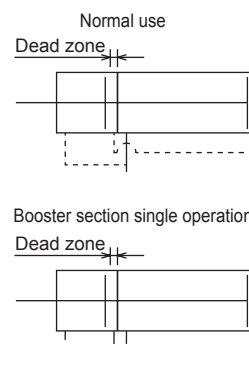

Min. stroke with switch

Bore size (mm)	When mounted on the same surface	When mounted on different surfaces
	$\varnothing 40$	
$\varnothing 50$		
$\varnothing 63$		
$\varnothing 80$		
$\varnothing 100$		

Switch specifications

● 1-color/2-color LED

Item	Proximity 2-wire			Proximity 3-wire	
	R1	R2	R2Y (2-color LED)	R3	R3Y (2-color LED)
Applications	Programmable controller, relay, compact solenoid valve		Dedicated for programmable controller		For programmable controller, relay, IC circuit, solenoid valve
Output method	-			NPN output	
Power supply voltage	-			4.5 VDC to 28 VDC	
Load voltage	85 VAC to 265 VAC		10 to 30 VDC		30 VDC or less
Load current	5 to 100 mA		5 to 30 mA		200 mA or less 100 mA or less
Indicator	LED (Lit when ON)			Red/green LED (Lit when ON)	LED (Lit when ON) Red/green LED (Lit when ON)
Leakage current	1 mA or less with 100 VAC, 2 mA or less with 200 VAC		1 mA or less		1.2 mA or less
Weight g	Grommet	1 m:42 3 m:100 5 m:158		1 m:56 3 m:114 5 m:172	1 m:42 3 m:100 5 m:158
	Terminal box	68		82	68 82

Item	Reed 2-wire								
	R0			R4		R5			R6
Applications	Relay, programmable controller			For high capacity relay, solenoid valve		For programmable controller, relay, IC circuit (without indicator lamp), serial connection			Dedicated for programmable controller (with DC self-hold)
Load voltage	12/24 VDC	110 VAC	220 VAC	110 VAC	220 VAC	12/24 VDC	110 VAC	220 VAC	24 VDC
Load current	5 to 50 mA	7 to 20 mA	7 to 10 mA	20 to 200 mA	10 to 200 mA	50 mA or less	20 mA or less	10 mA or less	5 to 50 mA
Indicator	LED (Lit when ON)			Neon lamp (Lit when OFF)		No indicator lamp			LED (Lit when ON)
Leakage current	0 mA			1 mA or less		0 mA			0.1 mA or less
Weight g	Grommet	1 m:42 3 m:100 5 m:158							
	Terminal box	68							

● Strong magnetic field proof

Item	Reed 2-wire			
	H0			
Applications	For relay, programmable controller			
Load voltage	12/24 VDC		110 VAC	
Load current	5 to 50 mA		7 to 20 mA	
Indicator	Green LED (Lit when ON)			
Leakage current	10 µA or less			
Weight g	1 m:76 3 m:181 5 m:289			

*1: Refer to Ending Page 1 for detailed switch specifications and dimensions.

Cylinder weight

(Unit: kg)

Bore size (mm)	Product weight when at 0 mm stroke						Switch weight	Mounting bracket weight		Additional weight per 100 mm cylinder stroke	Additional weight per 10 mm booster stroke	Additional weight of F type
	Basic	Axial foot	Flange	Eye bracket	Clevis bracket	Trunnion		R type	H type			
	(00)	(LB)	(FA/FB)	(CA)	(CB)	(TA/TB/TC)						
ø40	1.84	1.99	2.21	2.19	2.19	2.27	Refer to the weight in the switch specifications.	0.023	0.028	0.43	0.08	0.16
ø50	2.80	3.02	3.23	3.24	3.24	3.37		0.021	0.026	0.45	0.10	0.28
ø63	4.02	4.35	5.02	4.57	4.62	4.92		0.019	0.024	0.60	0.13	0.30
ø80	6.78	7.40	8.48	8.32	8.33	8.18		0.025	0.029	0.79	0.19	0.50
ø100	9.85	9.93	12.35	12.00	11.96	12.45		0.023	0.028	1.23	0.40	0.49

Formula for product weight
 (Example) SHC-LB-40H-200-20-R0-D-F

- Product weight at 0 mm stroke.....1.99 kg
- Additional weight per 200 mm stroke0.43x $\frac{200}{100}$ =0.86 kg
- Additional weight per 20 mm booster stroke0.08x $\frac{20}{10}$ =0.16 kg
- Additional weight of F type0.16 kg
- Weight of two RO switches0.042x2=0.084 kg
- Weight of 2 mounting brackets.....0.023x2=0.046 kg
- Product weight.....1.99+0.86+0.16+0.16+0.084+0.046=3.300 kg

LCM
LCR
LCG
LCW
LCX
STM
STG
STS/STL
STR2
UCA2
ULK*
JSK/M2
JSG
JSC3/JSC4
USSD
UFCD
USC
UB
JSB3
LMB
LML
HCM
HCA
LBC
CAC4
UCAC2
CAC-N
UCAC-N
RCS2
RCC2
PCC
SHC
MCP
GLC
MFC
BBS
RRC
GRC
RV3*
NHS
HRL
LN
Hand
Chuk
MechHnd/Chuk
ShkAbs
FJ
FK
SpdContr
Ending

SHC Series

How to order

- Without switch (built-in magnet for switch)
SHC - **LB** - **40** **H** - **100** - **20** ————— **S** **I**
- R type with switch (built-in magnet for switch)
SHC - **LB** - **40** **H** - **100** - **20** - **R0** - **R** - **S** **I**
- With strong magnetic field proof switch (H0, HOY) (built-in magnet for switch)
SHC-L2 - **LB** - **40** **H** - **100** - **20** - **H0** - **R** - **S** **I**

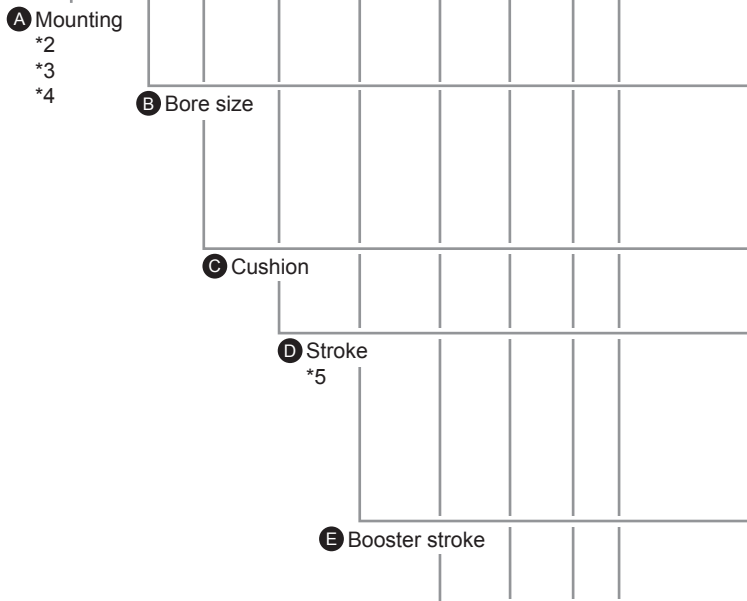

⚠ Precautions for model No. selection

- *1 : Mounting bracket will be shipped assembled with the product.
- *2 : For TA (rod side trunnion), the booster single control ports C/D are located on the bottom when viewed from the rod side. Refer to the booster single control port position full view on page 1162.
- *3 : In the case of the TA (rod side trunnion), since the trunnion mounting position is placed at the moving part of the stroke projection or booster section return, the position of the stroke projection of the cylinder switch or the booster section return cannot be detected.
- *4 : For TA (rod side trunnion) and TB (head side trunnion), piping port position cannot be specified on the trunnion shaft projecting surface.
- *5 : For the stroke indicated in Item **D** Stroke, indicate the full stroke (movement stroke + booster stroke).
- *6 : Refer to page 1144 for min. stroke with switch.
- *7 : When selecting TA or TB as mounting, the switch quantity is limited to "H" (1 on head side) for TA, and "R" (1 on rod side) for TB.
- *8 : L (bellows (for max. ambient temperature 250°C)) is available as a made-to-order product.
- *9 : Booster cylinder can be individually controlled. In this case, select option A (booster single control port).
- *10: "I" and "Y" cannot be selected together.
- *11: The piping port position R and T cannot be selected for FA (rod side flange).

[Example of model No.]

SHC-LB-40H-100-20-R0-R-S-I

Model No.: High power cylinder Double acting/double force

- A** Mounting : Axial foot
- B** Bore size : ø40 mm
- C** Cushion : Head side cushioned
- D** Stroke : 100 mm
(movement stroke 80 mm + booster stroke 20 mm)
- E** Booster stroke : 20 mm
- F** Switch model No.: Reed R0 switch, lead wire 1 m
- G** Switch quantity : 1 on rod side
- H** Option : Piping port position, bottom from rod side
- I** Accessory : Rod eye

Code	Description
A Mounting	
00	Basic
LB	Axial foot
FA	Rod side flange
FB	Head side flange
CA	Eye bracket
CB	Clevis bracket (pin and snap ring attached)
TA	Rod side trunnion
TB	Head side trunnion
TC	Intermediate trunnion

B Bore size (mm)	
40	ø40
50	ø50
63	ø63
80	ø80
100	ø100

C Cushion	
H	Head side cushioned
N	Without cushion

D Stroke (mm)		
Bore size	Stroke *6	Custom stroke
ø40	40 to 700	In 5 mm increments
ø50	40 to 700	
ø63	40 to 800	
ø80	40 to 900	
ø100	40 to 1000	

E Booster stroke (mm)	
10	10
20	20

F Switch model No.					
Grommet	Terminal box	Contact	Voltage AC/DC	Indicator	Lead wire
R1*	R1B	Proximity	●	1-color LED	2-wire
R2*	R2B		●	2-color LED	
R3*	R3B		●	1-color LED	3-wire
R3Y*	R3YB		●	2-color LED	
R0*	R0B	Reed	●	1-color LED	2-wire
R4*	R4B		●	no indicator lamp	
R5*	R5B		●	1-color LED	
R6*	R6B		●	Strong magn field proof SW	
HO*	-				

* Lead wire length	
Code	1 m (standard)
3	3 m (option)
5	5 m (option)

G Switch quantity	
R	1 on rod side
H	1 on head side
D	2
T	3
4	4
5	5

H Option		
	Max. ambient temperature	instantaneous max. temp
J	Bellows 100°C	200°C
L	Bellows 250°C	400°C
Blank	Rod end form/male thread (standard)	
F	Rod end form/flange	
Blank	Piping port position, top from rod side (standard)	
R	Piping port position, right from rod side	
S	Piping port position, bottom from rod side	
T	Piping port position, left from rod side	
G1	Metal scraper	
P6	Copper and PTFE free	
A	Booster single control port	

I Accessory	
I	Rod eye
Y	Rod clevis (pin and snap ring attached)
B11	Eye bracket (for clevis)
B21	Clevis bracket (for clevis)
B12	Eye bracket (for rod eye)
B22	Clevis bracket (for rod eye) (pin and snap ring attached)

How to order R-switch

A) Switch body + mounting bracket

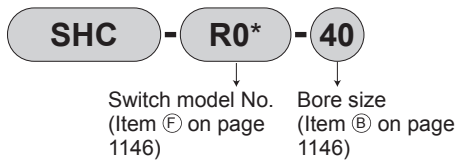

B) Switch body only

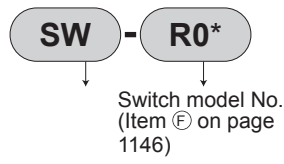

C) Mounting bracket set

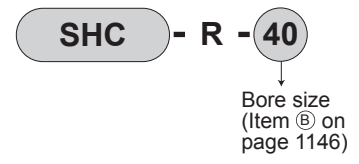

● Terminal box only

·For R□B

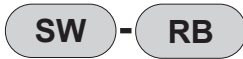

How to order H-switch

A) Switch body + mounting bracket set

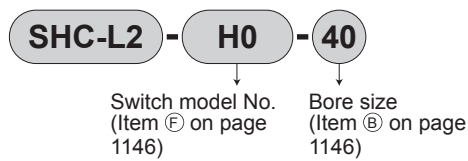

B) Switch body only

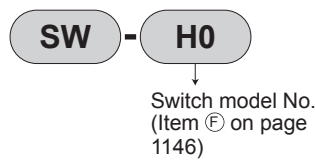

C) Mounting bracket set

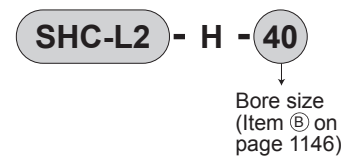

How to order mounting bracket

Table inside diameter (mm)	ø40	ø50	ø63	ø80	ø100
Mounting bracket					
Foot (LB) *1	SHC-LB-40	SHC-LB-50	SHC-LB-63	SHC-LB-80	SHC-LB-100
Rod side flange (FA)	SHC-FA-40	SHC-FA-50	SHC-FA-63	SHC-FA-80	SHC-FA-100
Head side flange (FB)	SHC-FB-40	SHC-FB-50	SHC-FB-63	SHC-FB-80	SHC-FB-100
Eye bracket (CA)	SHC-CA-40	SHC-CA-50	SHC-CA-63	SHC-CA-80	SHC-CA-100
Clevis bracket (CB)	SHC-CB-40	SHC-CB-50	SHC-CB-63	SHC-CB-80	SHC-CB-100

*1: The foot mounting bracket is provided as 2 pcs./set.

Theoretical thrust table

(Unit: N)

Bore size (mm)	Operating direction	Piston position	Working pressure MPa							
			0.2	0.3	0.4	0.5	0.6	0.7	0.8	0.9
ø40	Push	Thrust	2.51x10 ²	3.76x10 ²	5.02x10 ²	6.28x10 ²	7.53x10 ²	8.79x10 ²	1.0x10 ³	1.13x10 ³
		Booster section	5.2x10 ²	7.8x10 ²	1.04x10 ³	1.30x10 ³	1.56x10 ³	1.82x10 ³	2.08x10 ³	2.34x10 ³
	Pull	Thrust	1.28x10 ²	1.92x10 ²	2.56x10 ²	3.20x10 ²	3.84x10 ²	4.48x10 ²	5.12x10 ²	5.76x10 ²
		Booster section	3.97x10 ²	5.96x10 ²	7.95x10 ²	9.94x10 ²	1.19x10 ³	1.39x10 ³	1.59x10 ³	1.79x10 ³
ø50	Push	Thrust	3.92x10 ²	5.88x10 ²	7.85x10 ²	9.81x10 ²	1.18x10 ³	1.37x10 ³	1.57x10 ³	1.77x10 ³
		Booster section	8.55x10 ²	1.28x10 ³	1.71x10 ³	2.14x10 ³	2.57x10 ³	2.99x10 ³	3.42x10 ³	3.85x10 ³
	Pull	Thrust	2.31x10 ²	3.47x10 ²	4.63x10 ²	5.79x10 ²	6.95x10 ²	8.11x10 ²	9.27x10 ²	1.04x10 ³
		Booster section	6.94x10 ²	1.04x10 ³	1.39x10 ³	1.74x10 ³	2.08x10 ³	2.43x10 ³	2.78x10 ³	3.12x10 ³
ø63	Push	Thrust	6.23x10 ²	9.35x10 ²	1.25x10 ³	1.56x10 ³	1.87x10 ³	2.18x10 ³	2.49x10 ³	2.81x10 ³
		Booster section	1.26x10 ³	1.88x10 ³	2.51x10 ³	3.14x10 ³	3.77x10 ³	4.39x10 ³	5.02x10 ³	5.65x10 ³
	Pull	Thrust	3.72x10 ²	5.58x10 ²	7.44x10 ²	9.30x10 ²	1.12x10 ³	1.30x10 ³	1.49x10 ³	1.67x10 ³
		Booster section	1.00x10 ³	1.51x10 ³	2.01x10 ³	2.51x10 ³	3.01x10 ³	3.52x10 ³	4.02x10 ³	4.52x10 ³
ø80	Push	Thrust	1.01x10 ³	1.51x10 ³	2.01x10 ³	2.51x10 ³	3.02x10 ³	3.52x10 ³	4.02x10 ³	4.52x10 ³
		Booster section	1.88x10 ³	2.82x10 ³	3.77x10 ³	4.71x10 ³	5.65x10 ³	6.59x10 ³	7.53x10 ³	8.47x10 ³
	Pull	Thrust	6.12x10 ²	9.18x10 ²	1.23x10 ³	1.53x10 ³	1.84x10 ³	2.14x10 ³	2.45x10 ³	2.76x10 ³
		Booster section	1.49x10 ³	2.24x10 ³	2.98x10 ³	3.73x10 ³	4.47x10 ³	5.22x10 ³	5.96x10 ³	6.71x10 ³
ø100	Push	Thrust	1.57x10 ³	2.36x10 ³	3.14x10 ³	3.93x10 ³	4.71x10 ³	5.5x10 ³	6.28x10 ³	7.07x10 ³
		Booster section	2.91x10 ³	4.36x10 ³	5.81x10 ³	7.26x10 ³	8.72x10 ³	1.02x10 ⁴	1.16x10 ⁴	1.31x10 ⁴
	Pull	Thrust	1.01x10 ³	1.51x10 ³	2.01x10 ³	2.51x10 ³	3.02x10 ³	3.52x10 ³	4.02x10 ³	4.52x10 ³
		Booster section	2.34x10 ³	3.51x10 ³	4.68x10 ³	5.85x10 ³	7.02x10 ³	8.19x10 ³	9.36x10 ³	1.05x10 ⁴

Note: When the booster section is pulled (backward), due to product structure, theoretical thrust is reduced to approximately 70% when the connection is released.

- LCM
- LCR
- LCG
- LCW
- LCX
- STM
- STG
- STS/STL
- STR2
- UCA2
- ULK*
- JSK/M2
- JSG
- JSC3/JSC4
- USSD
- UFCD
- USC
- UB
- JSB3
- LMB
- LML
- HCM
- HCA
- LBC
- CAC4
- UCAC2
- CAC-N
- UCAC-N
- RCS2
- RCC2
- PCC
- SHC**
- MCP
- GLC
- MFC
- BBS
- RRC
- GRC
- RV3*
- NHS
- HRL
- LN
- Hand
- Chuk
- MechHnd/Chuk
- ShkAbs
- FJ
- FK
- SpdContr
- Ending

Internal structure and parts list

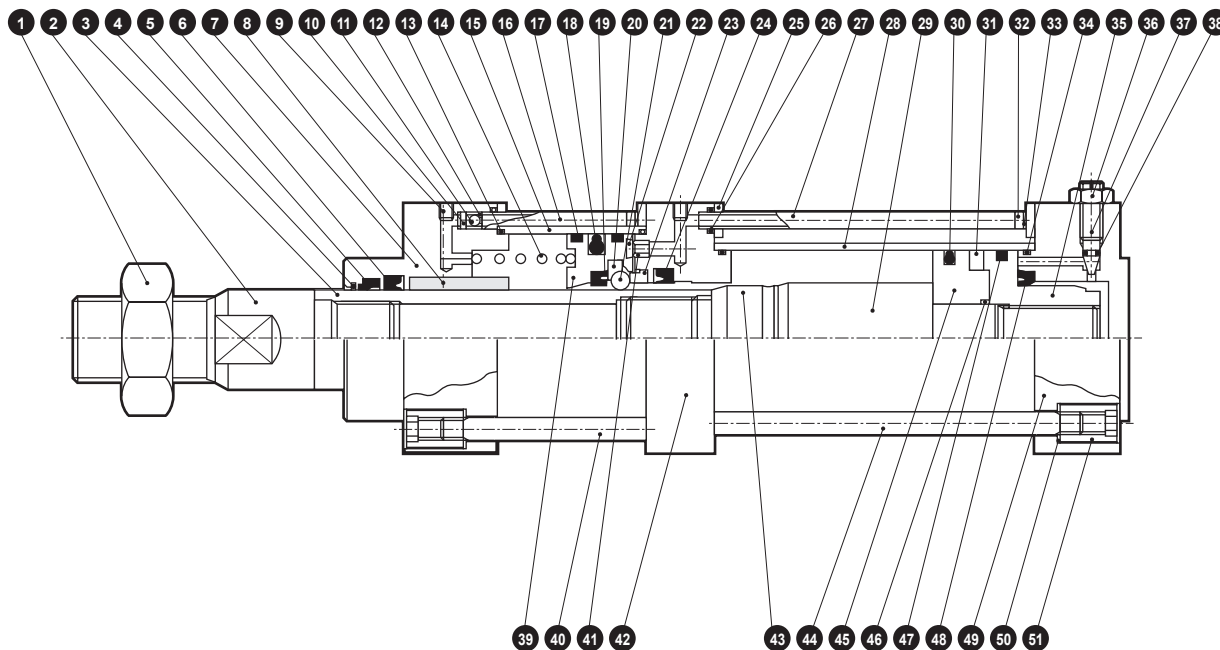

Cannot be disassembled

No.	Part name	Material	Remarks	No.	Part name	Material	Remarks
1	Rod nut	Steel	Zinc chromate	27	Pass-pipe (2)	Stainless steel	
2	Cap	Steel	Manganese phosphate	28	Cylinder tube	Aluminum alloy	Hard alumite
3	Piston rod	Steel	Industrial chrome plating	29	Connection piston	Steel	Industrial chrome plating
4	Metal scraper	Copper alloy	G1 type only	30	Piston packing (2)	Nitrile rubber	
5	Dust wiper	Nitrile rubber		31	Magnet	Plastic	
6	Rod packing (1)	Nitrile rubber		32	Hexagon socket head cap screw	Alloy steel	Black finish
7	Rod cover	Aluminum alloy	Black alumite	33	Spring washer	Steel	Black finish
8	Bush	Copper alloy casting	Oil impregnation	34	Cylinder gasket (2)	Nitrile rubber	
9	Hexagon socket set screw	Alloy steel	Black finish	35	Piston (H)	Aluminum alloy	
10	Spring pin	Steel		36	Needle nut	Copper alloy	Zinc chromate
11	Check ball	Alloy steel		37	Cushion needle	Copper alloy	
12	Fixed orifice	Copper alloy		38	Needle gasket	Nitrile rubber	
13	Cylinder gasket (1)	Nitrile rubber		39	Booster piston	Alloy steel	
14	Compression spring	Steel	Electrodeposition	40	Tie rod (1)	Steel	Zinc chromate
15	Booster pipe	Aluminum alloy	Hard alumite	41	Valve seat	Copper alloy	
16	Pass-pipe (1)	Stainless steel		42	Intermediate cover	Aluminum alloy	Black alumite
17	Wear ring (1)	Polyacetal		43	Connection collar	Alloy steel	
18	Piston packing (1)	Nitrile rubber		44	Tie rod (2)	Steel	Zinc chromate
19	Cushion packing (1)	Nitrile rubber		45	Piston (R)	Aluminum alloy	
20	Steel ball bearing	Nitrile rubber		46	Piston gasket	Nitrile rubber	
21	Steel ball	Alloy steel		47	Wear ring (2)	Acetal resin	
22	Seal cushion	Nitrile rubber		48	Cushion packing (2)	Nitrile rubber	
23	Ball stopper	Steel		49	Head cover	Aluminum alloy	Black alumite
24	Rod packing (2)	Nitrile rubber		50	Conical spring washer	Steel	Black finish
25	Packing holder	Steel	Manganese phosphate	51	Round nut	Steel	Zinc chromate
26	Pass-pipe gasket	Nitrile rubber					

Note: This product cannot be disassembled.

Dimensions



● Basic (00)

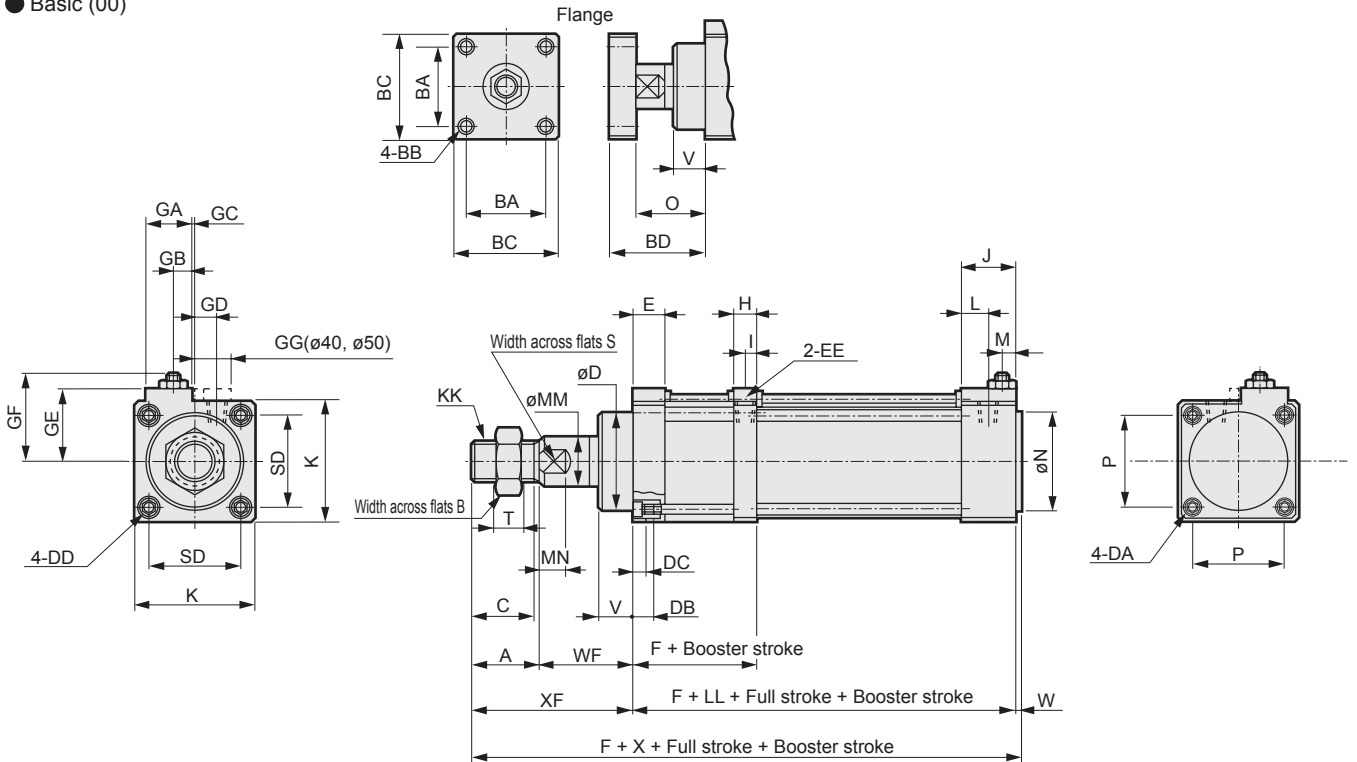

*1 : GG dimension applies to ø40 and ø50.

*2 : For dimensions with bellows, refer to page 1162.

*3 : For the dimensions of the accessories, refer to page 1163.

Bore size (mm)	Basic (00) basic dimensions																					
	A	B	BA	BB	BC	BD	C	D	DA	DB	DC	DD	E	EE	F	GA	GB	GC	GD	GE	GF	H
ø40	36	32	32	M8	50	68	34	ø43	M8	9	3.5	M6	25	Rc1/8	74.5	26	4	-	8.5	36.5	47.5	18
ø50	45	41	40	M10	60	75	43	ø51	M8	9	3.5	M6	26.5	Rc1/4	81	30	2	-	10	43	53.5	22
ø63	50	46	48	M12	70	74.5	47	ø57	M8	12	4	M8	33	Rc1/4	90	32	9	1	13	48	58	24
ø80	56	55	54	M14	80	89	53	ø62.5	M12	12	4	M10	34	Rc3/8	105	38	8	1	16	59	69	28
ø100	72	70	70	M16	100	100	69	ø75	M12	15	5	M12	37	Rc3/8	110.5	41	12.5	5	20	71	81	26

Bore size (mm)	Basic (00) basic dimensions																				
	I	J	K	KK	L	LL	M	MM	MN	N	O	P	S	SD	T	V	W	WF	X	XF	GG
ø40	8	26	57	M22x1.5	7	65.5	8	ø25	14	ø31	52	40.5	23	44	13	24	2	48	151.5	84	20
ø50	10.5	32	69	M26x1.5	9	73.5	9	ø30	17	ø38	54	48	26	56	16	24	2	53	173.5	98	20
ø63	11	30	80	M30x1.5	15	73	10	ø35	20	ø38	53	59	31	63	18	21	3	63	189	113	-
ø80	13	34	98	M36x1.5	17	87.5	11	ø40	26	ø43	64	74	36	78	21	24	2	70	215.5	126	-
ø100	14	37	118	M45x1.5	22	96	15	ø50	26	ø51	71	90	46	96	27	30	2	87	257	159	-

● R-switch mounting position

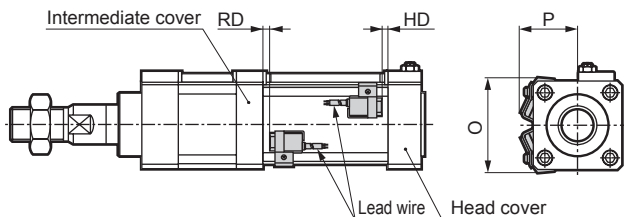

Bore size (mm)	RD	HD	O	P
ø40	6	4	66	42
ø50	4.5	7	73	44
ø63	7	6	84	47
ø80	12	11.5	104	58
ø100	12	16	120	64

● H-switch mounting position

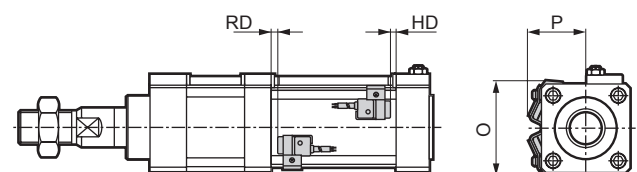

Bore size (mm)	RD	HD	O	P
ø40	4.5	2.5	66	42
ø50	3	5.5	73	44
ø63	5.5	4.5	84	47
ø80	10.5	10	104	58
ø100	10.5	14.5	120	64

LCM
LCR
LCG
LCW
LCX
STM
STG
STS/STL
STR2
UCA2
ULK*
JSK/M2
JSG
JSC3/JSC4
USSD
UFCD
USC
UB
JSB3
LMB
LML
HCM
HCA
LBC
CAC4
UCAC2
CAC-N
UCAC-N
RCS2
RCC2
PCC
SHC
MCP
GLC
MFC
BBS
RRC
GRC
RJ3*
NHS
HRL
LN
Hand
Chuk
MechHnd/Chuk
ShkAbs
FJ
FK
SpdContr
Ending



Dimensions

● Axial foot (LB)

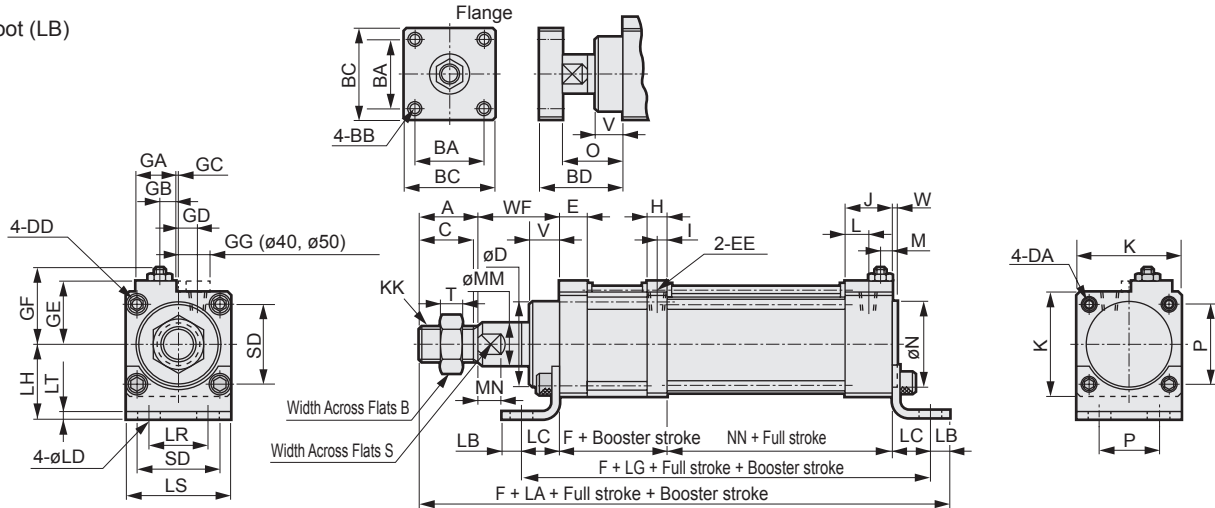

*1 : GG dimension applies to ø40 and ø50.

*2 : For dimensions with bellows, refer to page 1162.

*3 : For the dimensions of the accessories, refer to page 1163.

Bore size (mm)	Axial foot (LB) basic dimensions																						
	A	B	BA	BB	BC	BD	C	D	DA	DD	E	EE	F	GA	GB	GC	GD	GE	GF	H	I	J	K
ø40	36	32	32	M8	50	68	34	ø43	M8	M6	25	Rc1/8	74.5	26	4	-	8.5	36.5	47.5	18	8	26	57
ø50	45	41	40	M10	60	75	43	ø51	M8	M6	26.5	Rc1/4	81	30	2	-	10	43	53.5	22	10.5	32	69
ø63	50	46	48	M12	70	74.5	47	ø57	M8	M8	33	Rc1/4	90	32	9	1	13	48	58	24	11	30	80
ø80	56	55	54	M14	80	89	53	ø62.5	M12	M10	34	Rc3/8	105	38	8	1	16	59	69	28	13	34	98
ø100	72	70	70	M16	100	100	69	ø75	M12	M12	37	Rc3/8	110.5	41	12.5	5	20	71	81	26	14	37	118

Bore size (mm)	Axial foot (LB) basic dimensions																								
	KK	L	LA	LB	LC	LD	LG	LH	LR	LS	LT	M	MM	MN	N	NN	O	P	S	SD	T	V	W	WF	GG
ø40	M 22 x 1.5	7	179	10	19.5	9	104.5	40	40	57	3.2	8	ø25	14	ø31	65.5	52	40.5	23	44	13	24	2	48	20
ø50	M 26 x 1.5	9	205.5	12	22	9	117.5	40	46	69	4.5	9	ø30	17	ø38	73.5	54	48	26	56	16	24	2	53	20
ø63	M 30 x 1.5	15	228	12	30	11	133	50	60	80	4.5	10	ø35	20	ø38	73	53	59	31	63	18	21	3	63	-
ø80	M 36 x 1.5	17	264.5	14	37	14	161.5	60	74	98	6.0	11	ø40	26	ø43	87.5	64	74	36	78	21	24	2	70	-
ø100	M 45 x 1.5	22	307	21	31	14	158	67	80	118	6.0	15	ø50	26	ø51	96	71	90	46	96	27	30	2	87	-

● Rod side flange (FA)

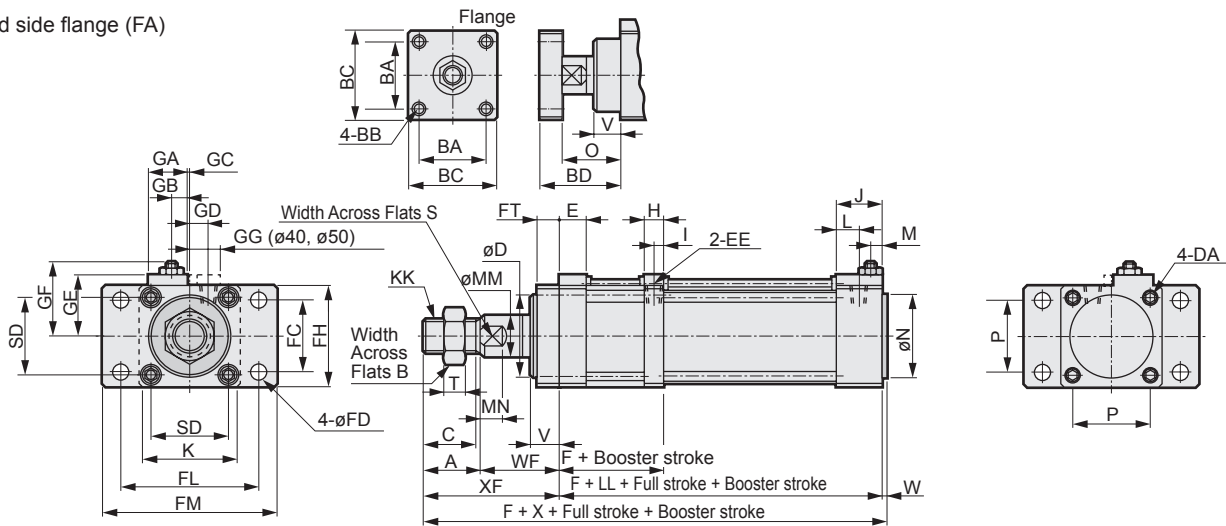

*1 : GG dimension applies to ø40 and ø50.

*2 : For dimensions with bellows, refer to page 1162.

*3 : For the dimensions of the accessories, refer to page 1163.

Bore size (mm)	Rod side flange (FA) basic dimensions																					
	A	B	BA	BB	BC	BD	C	D	DA	E	EE	F	FC	FD	FH	FL	FM	FT	GA	GB	GC	GD
ø40	36	32	32	M8	50	68	34	ø43	M8	25	Rc1/8	74.5	40	ø9	57	80	100	12	26	4	-	8.5
ø50	45	41	40	M10	60	75	43	ø51	M8	26.5	Rc1/4	81	47	ø9	69	85	108	12	30	2	-	10
ø63	50	46	48	M12	70	74.5	47	ø57	M8	33	Rc1/4	90	60	ø11	80	106	130	16	32	9	1	13
ø80	56	55	54	M14	80	89	53	ø62.5	M12	34	Rc3/8	105	74	ø14	98	125	153	19	38	8	1	16
ø100	72	70	70	M16	100	100	69	ø75	M12	37	Rc3/8	110.5	88	ø14	118	144	180	19	41	12.5	5	20

Bore size (mm)	Rod side flange (FA) basic dimensions																							
	GE	GF	H	I	J	K	KK	L	LL	M	MM	MN	N	O	P	S	SD	T	V	W	WF	X	XF	GG
ø40	36.5	47.5	18	8	26	57	M 22 x 1.5	7	65.5	8	ø25	14	ø31	52	40.5	23	44	13	24	2	48	151.5	84	20
ø50	43	53.5	22	10.5	32	69	M 26 x 1.5	9	73.5	9	ø30	17	ø38	54	48	26	56	16	24	2	53	173.5	98	20
ø63	48	58	24	11	30	80	M 30 x 1.5	15	73	10	ø35	20	ø38	53	59	31	63	18	21	3	63	189	113	-
ø80	59	69	28	13	34	98	M 36 x 1.5	17	87.5	11	ø40	26	ø43	64	74	36	78	21	24	2	70	215.5	126	-
ø100	71	81	26	14	37	118	M 45 x 1.5	22	96	15	ø50	26	ø51	71	90	46	96	27	30	2	87	257	159	-

Dimensions

● Head side flange (FB)

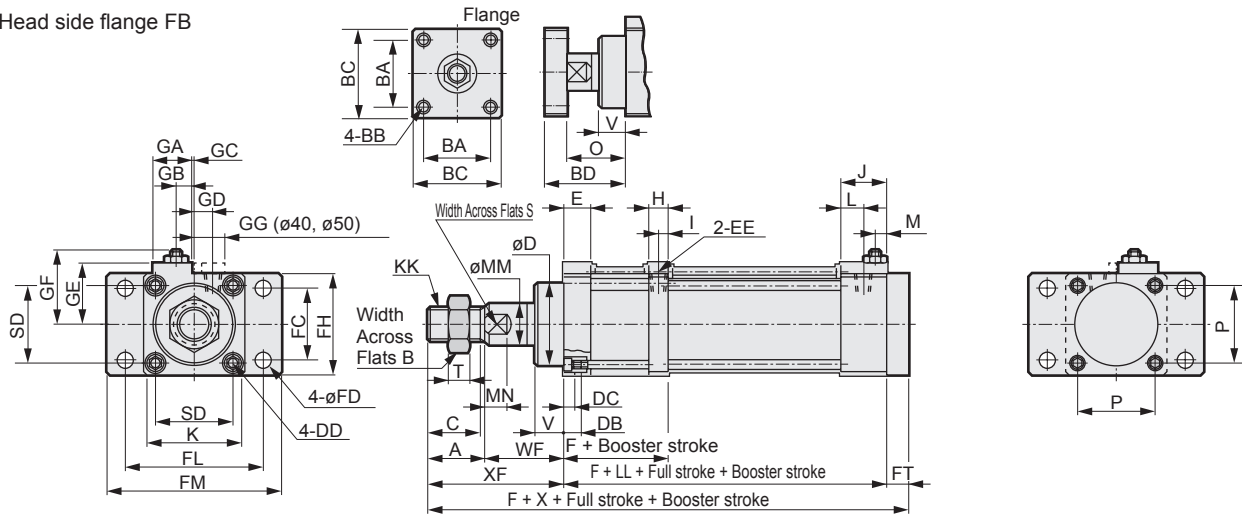

*1 : GG dimension applies to ø40 and ø50.

*2 : For dimensions with bellows, refer to page 1162.

*3 : For the dimensions of the accessories, refer to page 1163.

Bore size (mm)	Head side flange (FB) basic dimensions																							
	A	B	BA	BB	BC	BD	C	D	DB	DC	DD	E	EE	F	FC	FD	FH	FL	FM	FT	GA	GB	GC	GD
ø40	36	32	32	M8	50	68	34	ø43	9	3.5	M6	25	Rc1/8	74.5	40	ø9	57	80	100	12	26	4	-	8.5
ø50	45	41	40	M10	60	75	43	ø51	9	3.5	M6	26.5	Rc1/4	81	47	ø9	69	85	108	12	30	2	-	10
ø63	50	46	48	M12	70	74.5	47	ø57	12	4	M8	33	Rc1/4	90	60	ø11	80	106	130	16	32	9	1	13
ø80	56	55	54	M14	80	89	53	ø62.5	12	4	M10	34	Rc3/8	105	74	ø14	98	125	153	19	38	8	1	16
ø100	72	70	70	M16	100	100	69	ø75	15	5	M12	37	Rc3/8	110.5	88	ø14	118	144	180	19	41	12.5	5	20

Bore size (mm)	Head side flange (FB) basic dimensions																					
	GE	GF	H	I	J	K	KK	L	LL	M	MM	MN	O	P	S	SD	T	V	WF	X	XF	GG
ø40	36.5	47.5	18	8	26	57	M 22 x 1.5	7	65.5	8	ø25	14	52	40.5	23	44	13	24	48	161.5	84	20
ø50	43	53.5	22	10.5	32	69	M 26 x 1.5	9	73.5	9	ø30	17	54	48	26	56	16	24	53	183.5	98	20
ø63	48	58	24	11	30	80	M 30 x 1.5	15	73	10	ø35	20	53	59	31	63	18	21	63	202	113	-
ø80	59	69	28	13	34	98	M 36 x 1.5	17	87.5	11	ø40	26	64	74	36	78	21	24	70	232.5	126	-
ø100	71	81	26	14	37	118	M 45 x 1.5	22	96	15	ø50	26	71	90	46	96	27	30	87	274	159	-

● Eye bracket (CA)

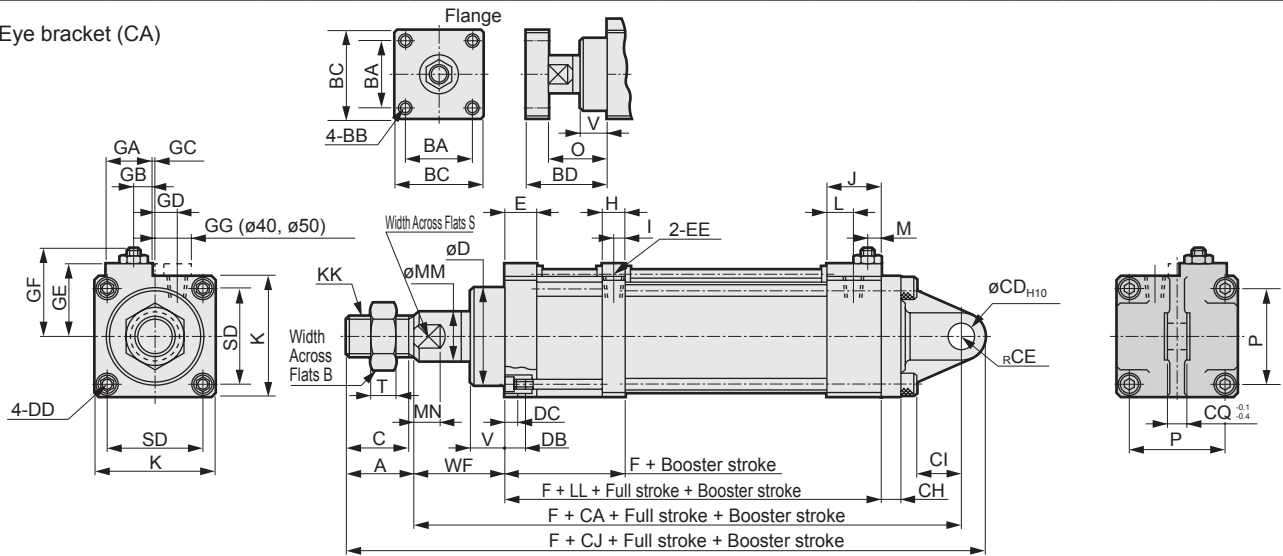

*1 : GG dimension applies to ø40 and ø50.

*2 : For dimensions with bellows, refer to page 1162.

*3 : For the dimensions of the accessories, refer to page 1163.

Bore size (mm)	Eye bracket (CA) basic dimensions																					
	A	B	BA	BB	BC	BD	C	CA	CD	CE	CH	CI	CJ	CQ	D	DB	DC	DD	E	EE	F	GA
ø40	36	32	32	M8	50	68	34	145.5	12	12	10	18	193.5	18	ø43	9	3.5	M6	25	Rc1/8	74.5	26
ø50	45	41	40	M10	60	75	43	158.5	12	12	10	18	215.5	18	ø51	9	3.5	M6	26.5	Rc1/4	81	30
ø63	50	46	48	M12	70	74.5	47	173	14	16	10	24	239	20	ø57	12	4	M8	33	Rc1/4	90	32
ø80	56	55	54	M14	80	89	53	209.5	20	20	14	30	285.5	28	ø62.5	12	4	M10	34	Rc3/8	105	38
ø100	72	70	70	M16	100	100	69	235	20	20	16	30	327	28	ø75	15	5	M12	37	Rc3/8	110.5	41

Bore size (mm)	Eye bracket (CA) basic dimensions																						
	GB	GC	GD	GE	GF	H	I	J	K	KK	L	LL	M	MM	MN	O	P	S	SD	T	V	WF	GG
ø40	4	-	8.5	36.5	47.5	18	8	26	57	M 22 x 1.5	7	65.5	8	ø25	14	52	40.5	23	44	13	24	48	20
ø50	2	-	10	43	53.5	22	10.5	32	69	M 26 x 1.5	9	73.5	9	ø30	17	54	48	26	56	16	24	53	20
ø63	9	1	13	48	58	24	11	30	80	M 30 x 1.5	15	73	10	ø35	20	53	59	31	63	18	21	63	-
ø80	8	1	16	59	69	28	13	34	98	M 36 x 1.5	17	87.5	11	ø40	26	64	74	36	78	21	24	70	-
ø100	12.5	5	20	71	81	26	14	37	118	M 45 x 1.5	22	96	15	ø50	26	71	90	46	96	27	30	87	-

- LCM
- LCR
- LCG
- LCW
- LCX
- STM
- STG
- STS/STL
- STR2
- UCA2
- ULK*
- JSK/M2
- JSG
- JSC3/JSC4
- USSD
- UFCD
- USC
- UB
- JSB3
- LMB
- LML
- HCM
- HCA
- LBC
- CAC4
- UCAC2
- CAC-N
- UCAC-N
- RCS2
- RCC2
- PCC
- SHC
- MCP
- GLC
- MFC
- BBS
- RRC
- GRC
- RV3*
- NHS
- HRL
- LN
- Hand
- Chuk
- MechHnd/Chuk
- ShkAbs
- FJ
- FK
- SpdContr
- Ending

SHC Series

Dimensions



● Clevis bracket (CB)

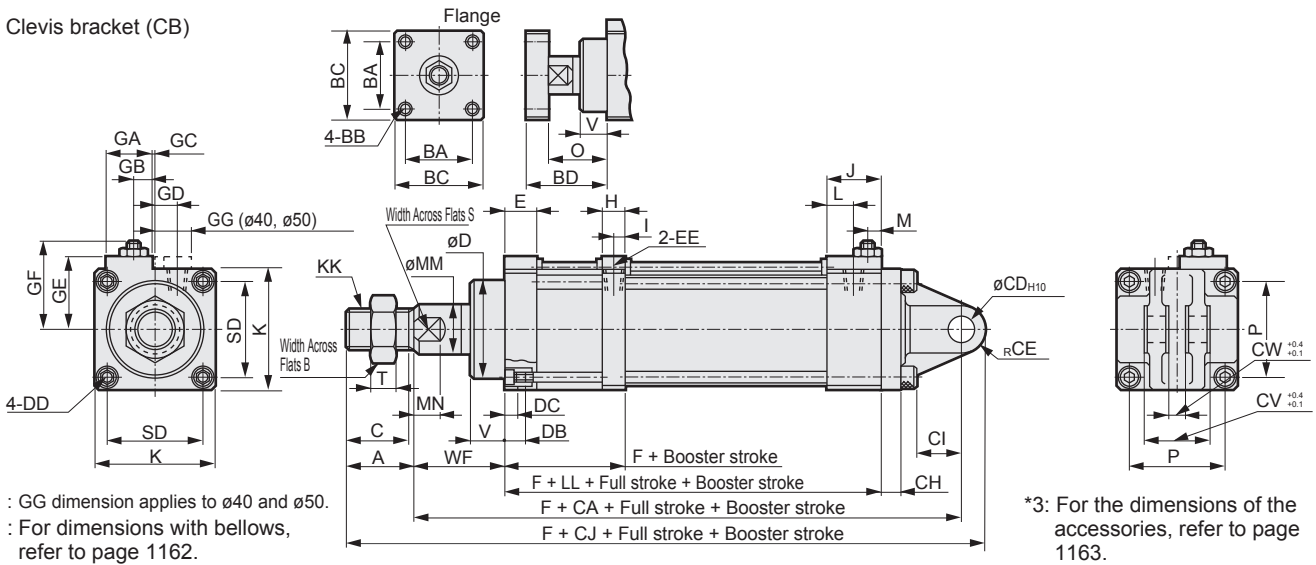

Bore size (mm)	Clevis bracket (CB) basic dimensions																					
	A	B	BA	BB	BC	BD	C	CA	CD	CE	CH	CI	CJ	CV	CW	D	DB	DC	DD	E	EE	F
$\phi 40$	36	32	32	M8	50	68	34	145.5	12	12	10	18	193.5	36	18	$\phi 43$	9	3.5	M6	25	Rc1/8	74.5
$\phi 50$	45	41	40	M10	60	75	43	158.5	12	12	10	18	215.5	36	18	$\phi 51$	9	3.5	M6	26.5	Rc1/4	81
$\phi 63$	50	46	48	M12	70	74.5	47	173	14	16	10	24	239	40	20	$\phi 57$	12	4	M8	33	Rc1/4	90
$\phi 80$	56	55	54	M14	80	89	53	209.5	20	20	14	30	285.5	56	28	$\phi 62.5$	12	4	M10	34	Rc3/8	105
$\phi 100$	72	70	70	M16	100	100	69	235	20	20	16	30	327	56	28	$\phi 75$	15	5	M12	37	Rc3/8	110.5

Bore size (mm)	Rod side trunnion (TA) basic dimensions																							
	GA	GB	GC	GD	GE	GF	H	I	J	K	KK	L	LL	M	MM	MN	O	P	S	SD	T	V	WF	GG
$\phi 40$	26	4	-	8.5	36.5	47.5	18	8	26	57	M 22 x 1.5	7	65.5	8	$\phi 25$	14	52	40.5	23	44	13	24	48	20
$\phi 50$	30	2	-	10	43	53.5	22	10.5	32	69	M 26 x 1.5	9	73.5	9	$\phi 30$	17	54	48	26	56	16	24	53	20
$\phi 63$	32	9	1	13	48	58	24	11	30	80	M 30 x 1.5	15	73	10	$\phi 35$	20	53	59	31	63	18	21	63	-
$\phi 80$	38	8	1	16	59	69	28	13	34	98	M 36 x 1.5	17	87.5	11	$\phi 40$	26	64	74	36	78	21	24	70	-
$\phi 100$	41	12.5	5	20	71	81	26	14	37	118	M 45 x 1.5	22	96	15	$\phi 50$	26	71	90	46	96	27	30	87	-

● Rod side trunnion (TA)

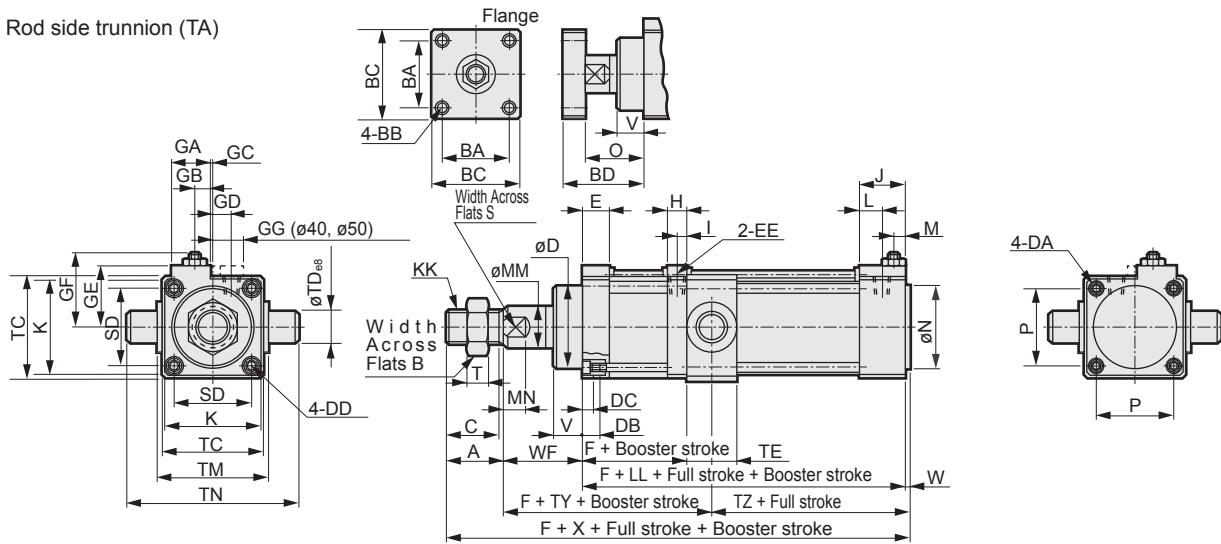

Bore size (mm)	Rod side trunnion (TA) basic dimensions																								
	A	B	BA	BB	BC	BD	C	D	DA	DB	DC	DD	E	EE	F	GA	GB	GC	GD	GE	GF	H	I	J	K
$\phi 40$	36	32	32	M8	50	68	34	$\phi 43$	M8	9	3.5	M6	25	Rc1/8	74.5	26	4	-	8.5	36.5	47.5	18	8	26	57
$\phi 50$	45	41	40	M10	60	75	43	$\phi 51$	M8	9	3.5	M6	26.5	Rc1/4	81	30	2	-	10	43	53.5	22	10.5	32	69
$\phi 63$	50	46	48	M12	70	74.5	47	$\phi 57$	M8	12	4	M8	33	Rc1/4	90	32	9	1	13	48	58	24	11	30	80
$\phi 80$	56	55	54	M14	80	89	53	$\phi 62.5$	M12	12	4	M10	34	Rc3/8	105	38	8	1	16	59	69	28	13	34	98
$\phi 100$	72	70	70	M16	100	100	69	$\phi 75$	M12	15	5	M12	37	Rc3/8	110.5	41	12.5	5	20	71	81	26	14	37	118

Bore size (mm)	Rod side trunnion (TA) basic dimensions																							
	KK	L	LL	M	MM	MN	N	O	P	S	SD	T	TC	TD	TE	TM	TN	TY	TZ	V	W	WF	X	GG
$\phi 40$	M 22 x 1.5	7	65.5	8	$\phi 25$	14	$\phi 31$	52	40.5	23	44	13	57	16	30	63	95	63	52.5	24	2	48	151.5	20
$\phi 50$	M 26 x 1.5	9	73.5	9	$\phi 30$	17	$\phi 38$	54	48	26	56	16	67	18	30	80	116	68	60.5	24	2	53	173.5	20
$\phi 63$	M 30 x 1.5	15	73	10	$\phi 35$	20	$\phi 38$	53	59	31	63	18	82	20	35	90	130	80.5	58.5	21	3	63	189	-
$\phi 80$	M 36 x 1.5	17	87.5	11	$\phi 40$	26	$\phi 43$	64	74	36	78	21	100	25	40	115	165	90	69.5	24	2	70	215.5	-
$\phi 100$	M 45 x 1.5	22	96	15	$\phi 50$	26	$\phi 51$	71	90	46	96	27	121	35	50	135	205	112	73	30	2	87	257	-

Dimensions

● Head side trunnion (TB)

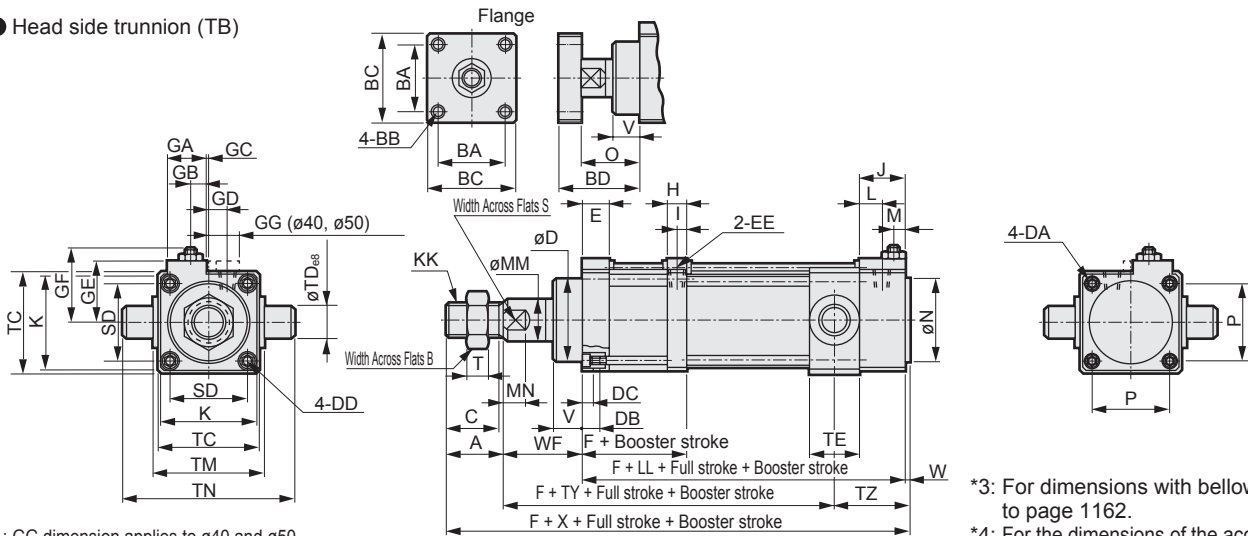

*1: GG dimension applies to $\phi 40$ and $\phi 50$.

*2: For all strokes 100mm or less, a cylinder switch cannot be installed.

*3: For dimensions with bellows, refer to page 1162.

*4: For the dimensions of the accessories, refer to page 1163.

Bore size (mm)	Head side trunnion (TB) basic dimensions																								
	A	B	BA	BB	BC	BD	C	D	DA	DB	DC	DD	E	EE	F	GA	GB	GC	GD	GE	GF	H	I	J	K
$\phi 40$	36	32	32	M8	50	68	34	$\phi 43$	M8	9	3.5	M6	25	Rc1/8	74.5	26	4	-	8.5	36.5	47.5	18	8	26	57
$\phi 50$	45	41	40	M10	60	75	43	$\phi 51$	M8	9	3.5	M6	26.5	Rc1/4	81	30	2	-	10	43	53.5	22	10.5	32	69
$\phi 63$	50	46	48	M12	70	74.5	47	$\phi 57$	M8	12	4	M8	33	Rc1/4	90	32	9	1	13	48	58	24	11	30	80
$\phi 80$	56	55	54	M14	80	89	53	$\phi 62.5$	M12	12	4	M10	34	Rc3/8	105	38	8	1	16	59	69	28	13	34	98
$\phi 100$	72	70	70	M16	100	100	69	$\phi 75$	M12	15	5	M12	37	Rc3/8	110.5	46	12.5	5	20	71	81	26	14	37	118

Bore size (mm)	Intermediate trunnion (TC) basic dimensions																							
	KK	L	LL	M	MM	MN	N	O	P	S	SD	T	TC	TD	TE	TM	TN	TY	TZ	V	W	WF	X	GG
$\phi 40$	M 22 x 1.5	7	65.5	8	$\phi 25$	14	$\phi 31$	52	40.5	23	44	13	57	16	30	63	95	72.5	43	24	2	48	151.5	20
$\phi 50$	M 26 x 1.5	9	73.5	9	$\phi 30$	17	$\phi 38$	54	48	26	56	16	67	18	30	80	116	79.5	49	24	2	53	173.5	20
$\phi 63$	M 30 x 1.5	15	73	10	$\phi 35$	20	$\phi 38$	53	59	31	63	18	82	20	35	90	130	88.5	50.5	21	3	63	189	-
$\phi 80$	M 36 x 1.5	17	87.5	11	$\phi 40$	26	$\phi 43$	64	74	36	78	21	100	25	40	115	165	103.5	56	24	2	70	215.5	-
$\phi 100$	M 45 x 1.5	22	96	15	$\phi 50$	26	$\phi 51$	71	90	46	96	27	121	35	50	135	205	121	64	30	2	87	257	-

● Intermediate trunnion (TC)

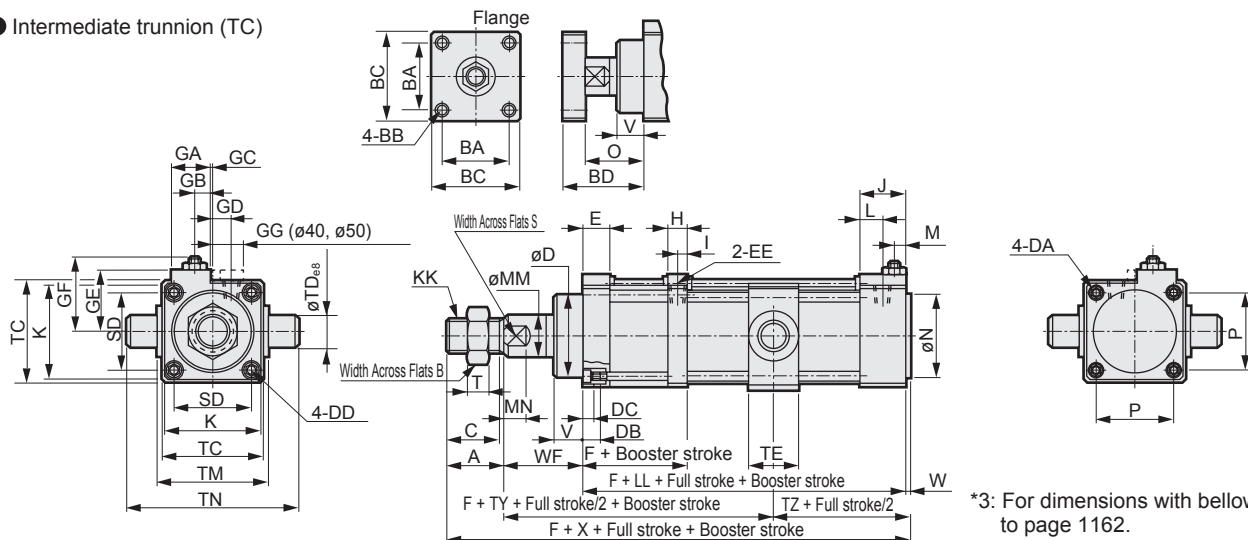

*1: GG dimension applies to $\phi 40$ and $\phi 50$.

*2: For all strokes 100mm or less, a cylinder switch cannot be installed.

*3: For dimensions with bellows, refer to page 1162.

*4: For the dimensions of the accessories, refer to page 1163.

Bore size (mm)	Intermediate trunnion (TC) basic dimensions																								
	A	B	BA	BB	BC	BD	C	D	DA	DB	DC	DD	E	EE	F	GA	GB	GC	GD	GE	GF	H	I	J	K
$\phi 40$	36	32	32	M8	50	68	34	$\phi 43$	M8	9	3.5	M6	25	Rc1/8	74.5	26	4	-	8.5	36.5	47.5	18	8	26	57
$\phi 50$	45	41	40	M10	60	75	43	$\phi 51$	M8	9	3.5	M6	26.5	Rc1/4	81	30	2	-	10	43	53.5	22	11	32	69
$\phi 63$	50	46	48	M12	70	74.5	47	$\phi 57$	M8	12	4	M8	33	Rc1/4	90	32	9	1	13	48	58	24	11	30	80
$\phi 80$	56	55	54	M14	80	89	53	$\phi 62.5$	M12	12	4	M10	34	Rc3/8	105	38	8	1	16	59	69	28	13	34	98
$\phi 100$	72	70	70	M16	100	100	69	$\phi 75$	M12	15	5	M12	37	Rc3/8	110.5	41	12.5	5	20	71	81	26	14	37	118

Bore size (mm)	Intermediate trunnion (TC) basic dimensions																							
	KK	L	LL	M	MM	MN	N	O	P	S	SD	T	TC	TD	TE	TM	TN	TY	TZ	V	W	WF	X	GG
$\phi 40$	M 22 x 1.5	7	65.5	8	$\phi 25$	14	$\phi 31$	52	40.5	23	44	13	57	16	30	63	95	68	47.5	24	2	48	151.5	20
$\phi 50$	M 26 x 1.5	9	73.5	9	$\phi 30$	17	$\phi 38$	54	48	26	56	16	67	18	30	80	116	74	54.5	24	2	53	173.5	20
$\phi 63$	M 30 x 1.5	15	73	10	$\phi 35$	20	$\phi 38$	53	59	31	63	18	82	20	35	90	130	84.5	54.5	21	3	63	189	-
$\phi 80$	M 36 x 1.5	17	87.5	11	$\phi 40$	26	$\phi 43$	64	74	36	78	21	100	25	40	115	165	97	62.5	24	2	70	215.5	-
$\phi 100$	M 45 x 1.5	22	96	15	$\phi 50$	26	$\phi 51$	71	90	46	96	27	121	35	50	135	205	116.5	68.5	30	2	87	257	-

- LCM
- LCR
- LCG
- LCW
- LCX
- STM
- STG
- STS/STL
- STR2
- UCA2
- ULK*
- JSK/M2
- JSG
- JSC3/JSC4
- USSD
- UFCD
- USC
- UB
- JSB3
- LMB
- LML
- HCM
- HCA
- LBC
- CAC4
- UCAC2
- CAC-N
- UCAC-N
- RCS2
- RCC2
- PCC
- SHC
- MCP
- GLC
- MFC
- BBS
- RRC
- GRC
- RV3*
- NHS
- HRL
- LN
- Hand
- Chuk
- MechHnd/Chuk
- ShkAbs
- FJ
- FK
- SpdContr
- Ending

High power cylinder/double acting/quad force

SHC-K Series

● Equivalent bore size: $\varnothing 40/\varnothing 50/\varnothing 63/\varnothing 80/\varnothing 100$



JIS symbol



LCM
LCR
LCG
LCW
LCX
STM
STG
STS/STL
STR2
UCA2
ULK*
JSK/M2
JSG
JSC3/JSC4
USSD
UFCD
USC
UB
JSB3
LMB
LML
HCM
HCA
LBC
CAC4
UCAC2
CAC-N
UCAC-N
RCS2
RCC2
PCC
SHC
MCP
GLC
MFC
BBS
RRC
GRC
RV3*
NHS
HRL
LN
Hand
Chuk
MechHnd/Chuk
ShkAbs
FJ
FK
SpdContr
Ending

Specifications

Item	SHC-K				
Bore size mm	$\varnothing 40$	$\varnothing 50$	$\varnothing 63$	$\varnothing 80$	$\varnothing 100$
Actuation	Double acting/projection quad force				
Working fluid	Compressed air				
Max. working pressure MPa	0.9 (≈ 130 psi, 9 bar)				
Min. working pressure MPa	0.2 (≈ 29 psi, 2 bar)	0.15 (≈ 22 psi, 1.5 bar)			
Proof pressure MPa	1.35 (≈ 200 psi, 13.5 bar)				
Ambient temperature $^{\circ}\text{C}$	-10 (14°F) to 60 (140°F) (no freezing)				
Port size Rc	1/8	1/4	1/4	3/8	3/8
Stroke tolerance mm	$^{+1.3}_0$ (to 300), $^{+1.7}_0$ (to 1000), $^{+2.1}_0$ (1000 to)				
Working piston	50 to 500				
speed *1 mm/s	10 to 30 (booster section single control)				
Cushion	Air cushion				
Lubrication	Not required (use turbine oil class 1 ISO VG32 if necessary for lubrication)				
Rod side allowable absorbed energy (J)	23.3	39.9	60.2	102	164
Head side allowable absorbed energy (J)	5.84	9.99	15.1	25.5	41.0

*1: As the piston speed differs depending on the supply pressure, refer to the technical data on page 1166.

Stroke

Bore size (mm)	Standard stroke (mm)	Max. stroke (mm)	Booster stroke	Dead zone
$\varnothing 40$	100, 150, 200, 250, 300, 400, 500	700	10, 20	1.9
$\varnothing 50$				1.9
$\varnothing 63$		800		2
$\varnothing 80$		900		2.3
$\varnothing 100$		1000		2.8

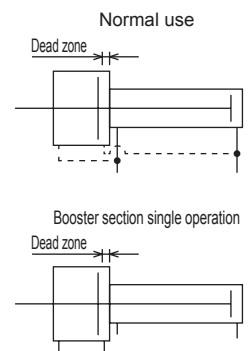

*1: The custom stroke is available in 5 mm increments.

*2: Dead zone (area not generating boosted thrust) stroke, until connection with booster piston completes, is included in the booster stroke.

*3: Min. stroke is 40 mm with or without switch. For types with switch, minimum stroke varies depending on mounting method. Refer to the following table.

Min. stroke with switch

Bore size (mm)	When mounted on the same surface	When mounted on different surfaces	
	$\varnothing 40$		
$\varnothing 50$	65		
$\varnothing 63$	40		
$\varnothing 80$			
$\varnothing 100$			

Switch specifications

● 1-color/2-color LED

Item	Proximity 2-wire			Proximity 3-wire	
	R1	R2	R2Y (2-color LED)	R3	R3Y (2-color LED)
Applications	Programmable controller, relay, compact solenoid valve		Dedicated for programmable controller	For programmable controller, relay, IC circuit, solenoid valve	
Output method	-			NPN output	
Power supply voltage	-			4.5 VDC to 28 VDC	
Load voltage	85 VAC to 265 VAC		10 to 30 VDC	30 VDC or less	
Load current	5 to 100 mA		5 to 30 mA	200 mA DC or less	100 mA DC or less
Indicator	LED (Lit when ON)		Red/green LED (Lit when ON)	LED (Lit when ON)	Red/green LED (Lit when ON)
Leakage current	1 mA or less with 100 VAC, 2 mA or less with 200 VAC		1 mA or less	1.2 mA or less	10 µA or less
Weightg	Grommet	1 m:42 3 m:100 5 m:158		1 m:56 3 m:114 5 m:172	1 m:42 3 m:100 5 m:158
	Terminal box	68		82	68 82

Item	Reed 2-wire						
	R0		R4		R5		R6
Applications	Relay, programmable controller		For high capacity relay, solenoid valve		For programmable controller, relay, IC circuit (without indicator lamp), serial connection		Dedicated for programmable controller (with DC self-hold)
Load voltage	12/24 VDC	110 VAC	220 VAC	110 VAC	220 VAC	12/24 VDC	110 VAC
Load current	5 to 50 mA	7 to 20 mA	7 to 10 mA	20 to 200 mA	10 to 200 mA	50 mA or less	20 mA or less
Indicator	LED (Lit when ON)		Neon lamp (Lit when OFF)		No indicator lamp		LED (Lit when ON)
Leakage current	0 mA		1 mA or less		0 mA		0.1 mA or less
Weightg	Grommet	1 m:42 3 m:100 5 m:158					
	Terminal box	68					

● Strong magnetic field

Item	Reed 2-wire	
	H0	
Applications	For relay, programmable controller	
Load voltage	12/24 VDC	110 VAC
Load current	5 to 50 mA	7 to 20 mA
Indicator	Green LED (Lit when ON)	
Leakage current	10 µA or less	
Weight g	1 m:76 3 m:181 5 m:289	

*1: Refer to Ending Page 1 for detailed switch specifications and dimensions.

LCM
LCR
LCG
LCW
LCX
STM
STG
STS/STL
STR2
UCA2
ULK*
JSK/M2
JSG
JSC3/JSC4
USSD
UFCD
USC
UB
JSB3
LMB
LML
HCM
HCA
LBC
CAC4
UCAC2
CAC-N
UCAC-N
RCS2
RCC2
PCC
SHC
MCP
GLC
MFC
BBS
RRC
GRC
RV3*
NHS
HRL
LN
Hand
Chuk
MechHnd/Chuk
ShkAbs
FJ
FK
SpdContr
Ending

Cylinder weight

(Unit: kg)

Bore size (mm)	Product weight when at 0 mm stroke				Switch weight	Mounting bracket weight		Additional weight per 100 mm cylinder stroke	Additional weight per 10 mm booster stroke	Additional weight of F type
	Basic (00)	Axial foot (LB)	Flange (FA)	Trunnion (TA)		R type	H type			
ø50	5.17	6.09	7.82	7.69	Refer to the weight in the switch specifications.	0.021	0.026	0.48	0.15	0.28
ø63	7.35	8.95	10.40	10.85		0.019	0.024	0.59	0.27	0.30
ø80	13.93	17.23	20.65	20.43		0.025	0.029	0.96	0.36	0.50
ø100	21.76	28.13	34.36	33.56		0.023	0.028	0.93	0.65	0.49

Formula for product weight
(Example) SHC-K-LB-40H-200-20-R0-D-F

- Product weight at 0 mm stroke..... 4.14 kg
- Additional weight per 200 mm stroke $0.43 \times \frac{200}{100} = 0.86$ kg
- Additional weight per 20 mm booster stroke $0.15 \times \frac{20}{10} = 0.30$ kg
- Additional weight of F type 0.16 kg
- Weight of two RO switches $0.042 \times 2 = 0.084$ kg
- Weight of 2 mounting brackets..... $0.023 \times 2 = 0.046$ kg
- Product weight..... $4.14 + 0.86 + 0.30 + 0.16 + 0.084 + 0.046 = 5.590$ kg

SHC-K Series

- LCM
- LCR
- LCG
- LCW
- LX
- STM
- STG
- STS/STL
- STR2
- UCA2
- ULK*
- JSK/M2
- JSG
- JSC3/JSC4
- USSD
- UFCD
- USC
- UB
- JSB3
- LMB
- LML
- HCM
- HCA
- LBC
- CAC4
- UCAC2
- CAC-N
- UCAC-N
- RCS2
- RCC2
- PCC
- SHC**
- MCP
- GLC
- MFC
- BBS
- RRC
- GRC
- RV3*
- NHS
- HRL
- LN
- Hand
- Chuk
- MechHnd/Chuk
- ShkAbs
- FJ
- FK
- SpdContr
- Ending

- Without switch (built-in magnet for switch)
SHC-K — **LB** - **40** **H** - **100** - **20** — **S** **I**
- R type with switch (built-in magnet for switch)
SHC-K — **LB** - **40** **H** - **100** - **20** - **R0** - **R** - **S** **I**
- With strong magnetic field proof switch (H0, H0Y) (built-in magnet for switch)
SHC-K-L2 - **LB** - **40** **H** - **100** - **20** - **H0** - **R** - **S** **I**

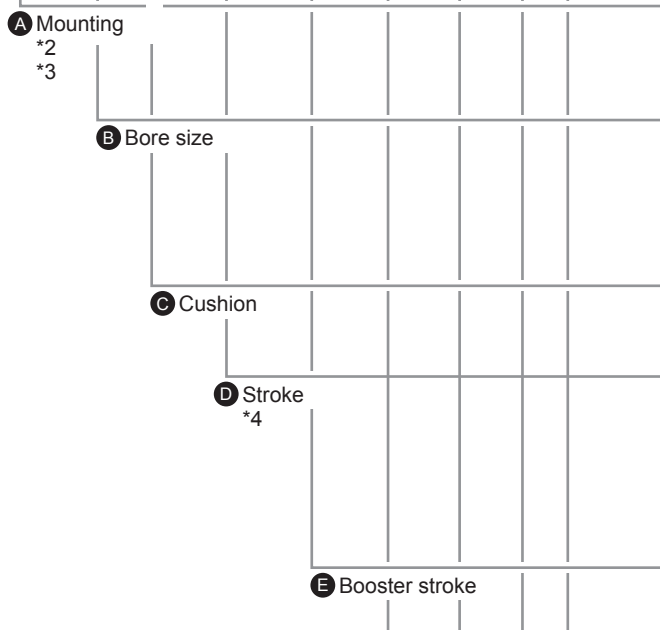

Code	Description
A Mounting	
LB	Axial foot
FA	Rod side flange
TA	Rod side trunnion

B Bore size (mm)	
40	ø40
50	ø50
63	ø63
80	ø80
100	ø100

C Cushion	
H	Head side cushioned
N	Without cushion

D Stroke (mm)		
Bore size	Stroke *5	Custom stroke
ø40	40 to 700	In 5 mm increments
ø50	40 to 700	
ø63	40 to 800	
ø80	40 to 900	
ø100	40 to 1000	

E Booster stroke (mm)	
10	10
20	20

F Switch model No.					
Grommet	Terminal box	Contact	Voltage AC/DC	Indicator	Lead wire
R1*	R1B	Proximity	●	1-color LED	2-wire
R2*	R2B		●	2-color LED	
R2Y*	R2YB		●	1-color LED	3-wire
R3*	R3B	●	2-color LED		
R3Y*	R3YB	Reed	●	1-color LED	2-wire
R0*	R0B		●	No indicator lamp	
R4*	R4B		●	1-color LED	2-wire
R5*	R5B		●	1-color LED	
R6*	R6B		●	Strong magn field proof SW	2-wire
H0*	-				

* Lead wire length	
Blank	1 m (standard)
3	3 m (option)
5	5 m (option)

G Switch quantity	
R	1 on rod side
H	1 on head side
D	2
T	3
4	4
5	5

H Option		
	Max. ambient temperature	Instantaneous max. temp
J	Bellows: 100°C	200°C
L	Bellows: 250°C	400°C
Blank	Rod end form/male thread (standard)	
F	Rod end form/flange	
Blank	Piping port position, top from rod side (standard)	
R	Piping port position, right from rod side	
S	Piping port position, bottom from rod side	
T	Piping port position, left from rod side	
G1	Metal scraper	
P6	Copper and PTFE free	
A	Booster single control port	

I Accessory	
I	Rod eye
Y	Rod clevis (pin and snap ring attached)
B12	Eye bracket (for rod eye)
B22	Clevis bracket (for rod eye) (pin and snap ring attached)

F Switch model No.
* indicates the lead wire length.

G Switch quantity
*6

H Option
*7
*8

I Accessory

⚠ Precautions for model No. selection

- *1 : Mounting bracket will be shipped assembled with the product.
- *2 : In the case of TA (rod side trunnion), since the trunnion mounting position is placed at the moving part of the stroke projection or booster section return, the position of the stroke projection of the cylinder switch and the booster section return cannot be detected.
- *3 : For TA (rod side trunnion) and TB (head side trunnion), piping port position cannot be specified on the trunnion shaft projecting surface.
- *4 : For the stroke indicated in Item **D** Stroke, indicate the full stroke (movement stroke + booster stroke).
- *5 : Refer to page 1154 for the min. stroke with switch.
- *6 : When selecting TA or TB as mounting, the number of switches is limited to "H" (1 on head side) for TA, and "R" (1 on rod side) for TB.
- *7 : L (bellows (for max. ambient temperature 100°C)) is available as a made-to-order product.
- *8 : Booster cylinder can be individually controlled. In this case, select option A (booster single control port).

[Example of model No.]

SHC-K-LB-40H-100-20-R0-R-S-I

Model No.: High power cylinder Double acting/quad force

- A** Mounting : Axial foot
- B** Bore size : ø40 mm
- C** Cushion : Head side cushioned
- D** Stroke : 100 mm
(movement stroke 80 mm + booster stroke 20 mm)
- E** Booster stroke : 20 mm
- F** Switch model No. : Reed R0 switch, lead wire 1 m
- G** Switch quantity : 1 on rod side
- H** Option : Piping port position, bottom from rod side
- I** Accessory : Rod eye

How to order R-switch

A) Switch body + mounting bracket

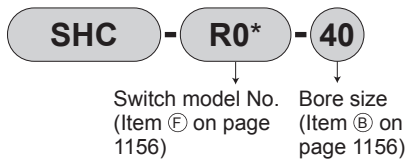

B) Switch body only

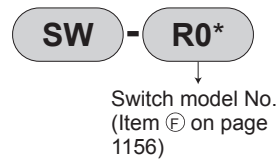

C) Mounting bracket set

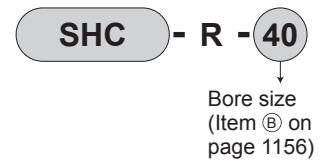

● Terminal box only

For R□B

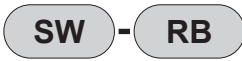

How to order H-switch

A) Switch body + mounting bracket set

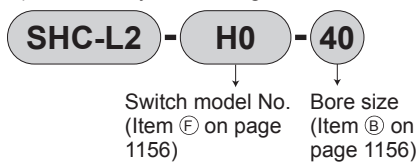

B) Switch body only

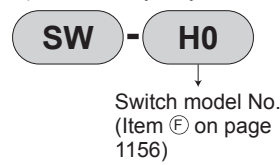

C) Mounting bracket set

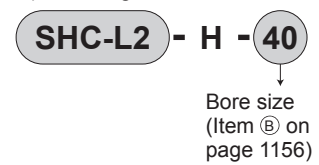

How to order mounting bracket

Bore size (mm)	ø40	ø50
Mounting bracket	SHC-K-FA-40	SHC-K-FA-50
Rod side flange (FA)	SHC-K-FA-40	SHC-K-FA-50

*1: Order for mounting bracket only is not possible for ø63 to ø100.

Theoretical thrust table

(Unit: N)

Bore size (mm)	Operating direction	Piston position	Working pressure MPa							
			0.2	0.3	0.4	0.5	0.6	0.7	0.8	0.9
ø40	Push	Thrust	2.51x10 ²	3.76x10 ²	5.02x10 ²	6.28x10 ²	7.53x10 ²	8.79x10 ²	1.0x10 ³	1.13x10 ³
		Booster section	1.13x10 ³	1.70x10 ³	2.27x10 ³	2.83x10 ³	3.40x10 ³	3.97x10 ³	4.53x10 ³	5.10x10 ³
	Pull	Thrust	1.28x10 ²	1.92x10 ²	2.56x10 ²	3.20x10 ²	3.84x10 ²	4.48x10 ²	5.12x10 ²	5.76x10 ²
		Booster section	1.01x10 ³	1.52x10 ³	2.02x10 ³	2.53x10 ³	3.03x10 ³	3.54x10 ³	4.04x10 ³	4.55x10 ³
ø50	Push	Thrust	3.92x10 ²	5.88x10 ²	7.85x10 ²	9.81x10 ²	1.18x10 ³	1.37x10 ³	1.57x10 ³	1.77x10 ³
		Booster section	1.80x10 ³	2.70x10 ³	3.60x10 ³	4.51x10 ³	5.41x10 ³	6.31x10 ³	7.21x10 ³	8.11x10 ³
	Pull	Thrust	2.31x10 ²	3.47x10 ²	4.63x10 ²	5.79x10 ²	6.95x10 ²	8.11x10 ²	9.27x10 ²	1.04x10 ³
		Booster section	1.64x10 ³	2.46x10 ³	3.28x10 ³	4.10x10 ³	4.92x10 ³	5.75x10 ³	6.57x10 ³	7.39x10 ³
ø63	Push	Thrust	6.23x10 ²	9.35x10 ²	1.25x10 ³	1.56x10 ³	1.87x10 ³	2.18x10 ³	2.49x10 ³	2.81x10 ³
		Booster section	2.83x10 ³	4.24x10 ³	5.65x10 ³	7.07x10 ³	8.48x10 ³	9.89x10 ³	1.13x10 ⁴	1.27x10 ⁴
	Pull	Thrust	3.72x10 ²	5.58x10 ²	7.44x10 ²	9.30x10 ²	1.12x10 ³	1.30x10 ³	1.49x10 ³	1.67x10 ³
		Booster section	2.58x10 ³	3.86x10 ³	5.15x10 ³	6.44x10 ³	7.73x10 ³	9.01x10 ³	1.03x10 ⁴	1.16x10 ⁴
ø80	Push	Thrust	1.01x10 ³	1.51x10 ³	2.01x10 ³	2.51x10 ³	3.02x10 ³	3.52x10 ³	4.02x10 ³	4.52x10 ³
		Booster section	4.63x10 ³	6.95x10 ³	9.27x10 ³	1.16x10 ⁴	1.39x10 ⁴	1.62x10 ⁴	1.85x10 ⁴	2.09x10 ⁴
	Pull	Thrust	6.12x10 ²	9.18x10 ²	1.23x10 ³	1.53x10 ³	1.84x10 ³	2.14x10 ³	2.45x10 ³	2.76x10 ³
		Booster section	4.24x10 ³	6.36x10 ³	8.48x10 ³	1.06x10 ⁴	1.27x10 ⁴	1.48x10 ⁴	1.70x10 ⁴	1.91x10 ⁴
ø100	Push	Thrust	1.57x10 ³	2.36x10 ³	3.14x10 ³	3.93x10 ³	4.71x10 ³	5.50x10 ³	6.28x10 ³	7.07x10 ³
		Booster section	7.29x10 ³	1.09x10 ⁴	1.46x10 ⁴	1.82x10 ⁴	2.19x10 ⁴	2.55x10 ⁴	2.91x10 ⁴	3.28x10 ⁴
	Pull	Thrust	1.01x10 ³	1.51x10 ³	2.01x10 ³	2.51x10 ³	3.02x10 ³	3.52x10 ³	4.02x10 ³	4.52x10 ³
		Booster section	6.72x10 ³	1.01x10 ⁴	1.34x10 ⁴	1.68x10 ⁴	2.02x10 ⁴	2.35x10 ⁴	2.69x10 ⁴	3.02x10 ⁴

Note: When the booster section is pulled (backward), due to product structure, theoretical thrust is reduced to approximately 70% when the connection is released.

- LCM
- LCR
- LCG
- LCW
- LCX
- STM
- STG
- STS/STL
- STR2
- UCA2
- ULK*
- JSK/M2
- JSG
- JSC3/JSC4
- USSD
- UFCD
- USC
- UB
- JSB3
- LMB
- LML
- HCM
- HCA
- LBC
- CAC4
- UCAC2
- CAC-N
- UCAC-N
- RCS2
- RCC2
- PCC
- SHC**
- MCP
- GLC
- MFC
- BBS
- RRC
- GRC
- RV3*
- NHS
- HRL
- LN
- Hand
- Chuk
- MechHnd/Chuk
- ShkAbs
- FJ
- FK
- SpdContr
- Ending

Internal structure and parts list (ø40, ø50)

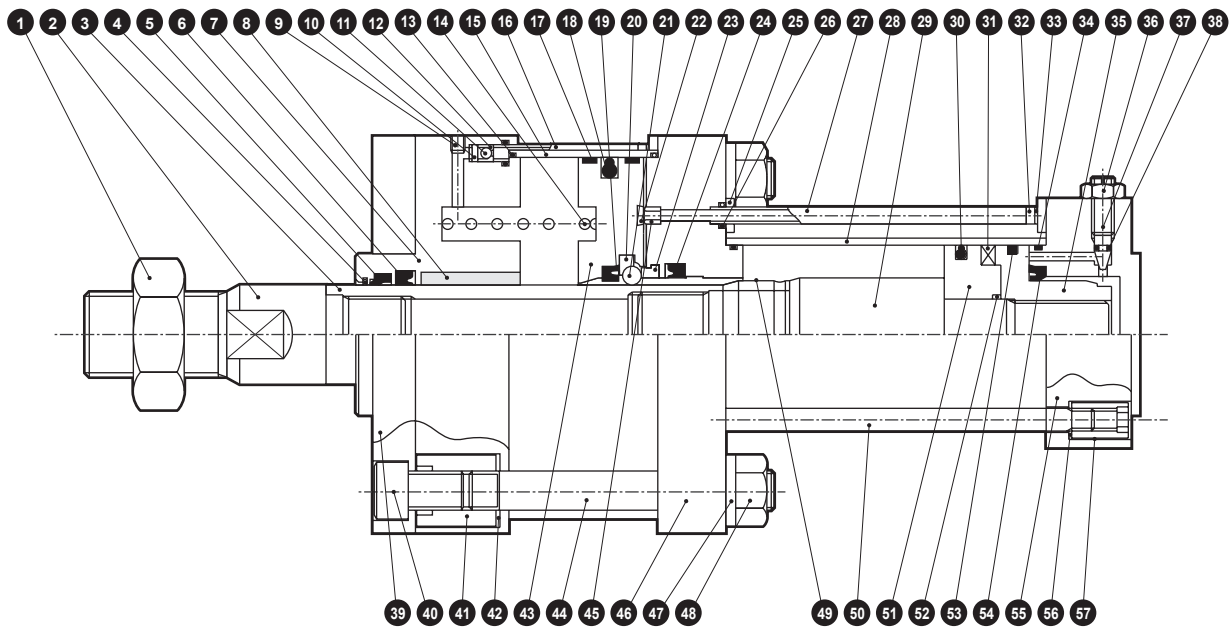

Cannot be disassembled

No.	Part name	Material	Remarks	No.	Part name	Material	Remarks
1	Rod nut	Steel	Zinc chromate	30	Piston packing (2)	Nitrile rubber	
2	Cap	Steel	Manganese phosphate	31	Magnet	Plastic	
3	Piston rod	Steel	Industrial chrome plating	32	Hexagon socket head cap screw	Alloy steel	Black finish
4	Metal scraper	Copper alloy	G1 type only	33	Spring washer	Steel	Black finish
5	Dust wiper	Nitrile rubber		34	Cylinder gasket (2)	Nitrile rubber	
6	Rod packing (1)	Nitrile rubber		35	Piston (H)	Aluminum alloy	
7	Rod cover	Aluminum alloy	Black alumite	36	Needle nut	Copper alloy	Zinc chromate
8	Bush	Copper alloy casting	Oil impregnation	37	Cushion needle	Copper alloy	
9	Hexagon socket set screw	Alloy steel	Black finish	38	Needle gasket	Nitrile rubber	
10	Spring pin	Steel		39	FA flange	Steel	Paint
11	Check ball	Alloy steel		40	Hexagon socket head cap screw	Alloy steel	Black finish
12	Fixed orifice	Copper alloy		41	Round nut (1)	Steel	Zinc chromate
13	Cylinder gasket (1)	Nitrile rubber		42	Conical spring washer (1)	Steel	Black finish
14	Compression spring	Steel	Electrodeposition	43	Booster piston	Alloy steel	
15	Booster pipe	Aluminum alloy	Hard alumite	44	Tie rod (1)	Steel	Zinc chromate
16	Pass-pipe (1)	Stainless steel		45	Valve seat	Copper alloy	
17	Wear ring (1)	Polyacetal		46	Intermediate cover	Aluminum alloy	Black alumite
18	Piston packing (1)	Nitrile rubber		47	Toothed washer	Steel	Zinc chromate
19	Cushion packing (1)	Nitrile rubber		48	Hexagon nut	Steel	Zinc chromate
20	Steel ball bearing	Nitrile rubber		49	Connection collar	Alloy steel	
21	Steel ball	Alloy steel		50	Tie rod (2)	Steel	Zinc chromate
22	Seal cushion	Nitrile rubber		51	Piston (R)	Aluminum alloy	
23	Ball stopper	Steel		52	Piston gasket	Nitrile rubber	
24	Rod packing (2)	Nitrile rubber		53	Wear ring (2)	Polyacetal	
25	Packing holder	Steel	Manganese phosphate	54	Cushion packing (2)	Nitrile rubber	
26	Pass-pipe gasket	Nitrile rubber		55	Head cover	Aluminum alloy	Black alumite
27	Pass-pipe (2)	Stainless steel		56	Conical spring washer	Steel	Black finish
28	Cylinder tube	Aluminum alloy	Hard alumite	57	Round nut (2)	Steel	Zinc chromate
29	Connection piston	Steel	Industrial chrome plating				

Note: This product cannot be disassembled.

Internal structure and parts list (ø63 to ø100)

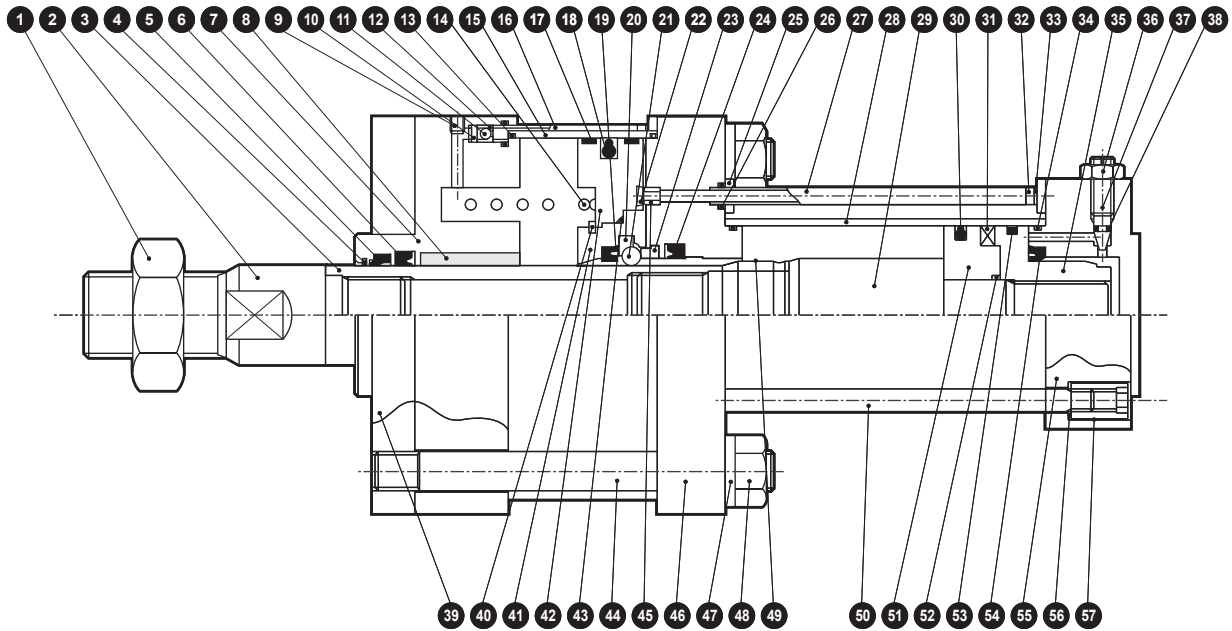

Cannot be disassembled

No.	Part name	Material	Remarks	No.	Part name	Material	Remarks
1	Rod nut	Steel	Zinc chromate	30	Piston packing (2)	Nitrile rubber	
2	Cap	Steel	Manganese phosphate	31	Magnet	Plastic	
3	Piston rod	Steel	Industrial chrome plating	32	Hexagon socket head cap screw	Steel	Black finish
4	Metal scraper	Copper alloy	G1 type only	33	Spring washer	Steel	Black finish
5	Dust wiper	Nitrile rubber		34	Cylinder gasket (2)	Nitrile rubber	
6	Rod packing (1)	Nitrile rubber		35	Piston (H)	Aluminum alloy	
7	Rod cover	Aluminum alloy	Black alumite	36	Needle nut	Copper alloy	Zinc chromate
8	Bush	Copper alloy casting	Oil impregnation	37	Cushion needle	Copper alloy	
9	Hexagon socket set screw	Alloy steel	Black finish	38	Needle gasket	Nitrile rubber	
10	Spring pin	Steel		39	FA flange	Steel	Electrodeposition
11	Check ball	Alloy steel		40	C-snap ring	Steel	
12	Fixed orifice	Copper alloy		41	Booster piston (A)	Alloy steel	
13	Cylinder gasket (1)	Nitrile rubber		42	Booster piston (B)	Steel	Zinc chromate
14	Compression spring	Steel	Electrodeposition	43	Gasket	Nitrile rubber	
15	Booster pipe	Aluminum alloy	Hard alumite	44	Tie rod (1)	Steel	Zinc chromate
16	Pass-pipe (1)	Stainless steel		45	Valve seat	Copper alloy	
17	Wear ring (1)	Polyacetal		46	Intermediate cover	Aluminum alloy	Black alumite
18	Piston packing (1)	Nitrile rubber		47	Toothed washer	Steel	Zinc chromate
19	Cushion packing (1)	Nitrile rubber		48	Hexagon nut	Steel	Zinc chromate
20	Steel ball bearing	Nitrile rubber		49	Connection collar	Alloy steel	
21	Steel ball	Alloy steel		50	Tie rod (2)	Steel	Zinc chromate
22	Seal cushion	Urethane rubber		51	Piston (R)	Aluminum alloy	
23	Ball stopper	Steel		52	Piston gasket	Nitrile rubber	
24	Rod packing (2)	Nitrile rubber		53	Wear ring (2)	Polyacetal	
25	Packing holder	Steel	Manganese phosphate	54	Cushion packing (2)	Nitrile rubber	
26	Pass-pipe gasket	Nitrile rubber		55	Head cover	Aluminum alloy	Black alumite
27	Pass-pipe (2)	Stainless steel		56	Conical spring washer	Steel	Black finish
28	Cylinder tube	Aluminum alloy	Hard alumite	57	Round nut	Steel	Zinc chromate
29	Connection piston	Steel	Industrial chrome plating				

Note: This product cannot be disassembled.

- LCM
- LCR
- LCG
- LCW
- LCX
- STM
- STG
- STS/STL
- STR2
- UCA2
- ULK*
- JSK/M2
- JSG
- JSC3/JSC4
- USSD
- UFCD
- USC
- UB
- JSB3
- LMB
- LML
- HCM
- HCA
- LBC
- CAC4
- UCAC2
- CAC-N
- UCAC-N
- RCS2
- RCC2
- PCC
- SHC
- MCP
- GLC
- MFC
- BBS
- RRC
- GRC
- RV3*
- NHS
- HRL
- LN
- Hand
- Chuk
- MechHnd/Chuk
- ShkAbs
- FJ
- FK
- SpdContr
- Ending



Dimensions [axial foot (LB), rod side flange (FA)]

● Axial foot (LB)

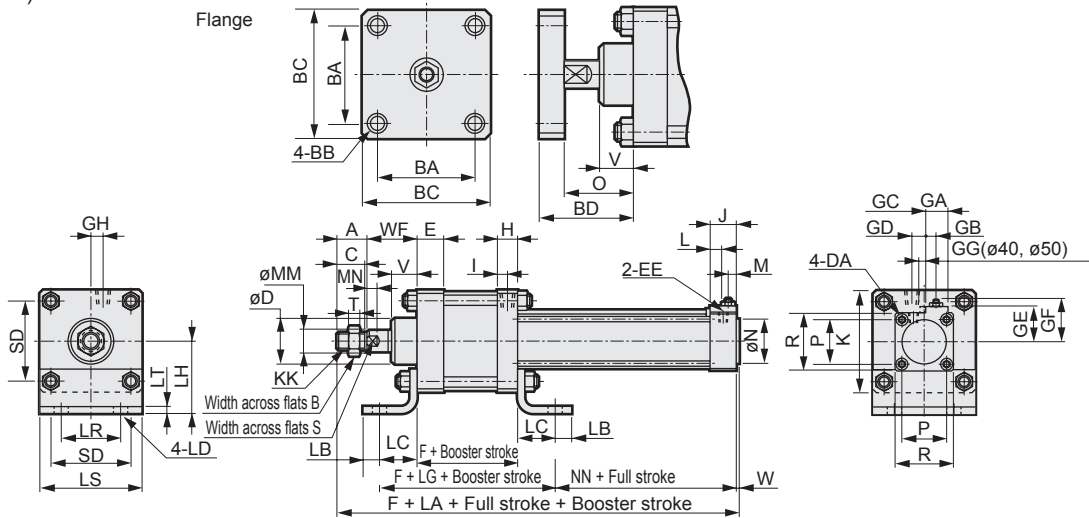

*1 : GG dimension applies to ø40 and ø50.

*2 : For dimensions with bellows, refer to page 1162.

*3 : For the dimensions of the accessories, refer to page 1163.

Bore size (mm)	A	B	BA	BB	BC	BD	C	D	DA	E	EE	F	GA	GB	GC	GD	GE	GF	GH	H	I	J	K	KK
ø40	36	32	50	M12	74	68	34	ø43	M8	35	Rc1/8	84.5	26	4	-	8.5	36.5	47.5	12	18	10	26	98	M22x1.5
ø50	45	41	60	M12	90	75	43	ø51	M8	36	Rc1/4	90.5	30	2	-	10	43	53.5	16	22	11.5	32	118	M26x1.5
ø63	50	46	80	M14	110	74	47	ø57	M8	33	Rc1/4	90	32	9	1	13	48	58	13	24	13	30	140	M30x1.5
ø80	56	55	110	M16	142	89	53	ø62.5	M12	34	Rc3/8	105	38	8	1	16	59	69	15	28	15	34	177	M36x1.5
ø100	72	70	130	M20	175	100	69	ø75	M12	37	Rc3/8	110.5	41	12.5	5	20	71	81	20	26	13	37	220	M45x1.5

Bore size (mm)	L	LA	LB	LC	LD	LG	LH	LR	LS	LT	M	MM	MN	N	NN	O	P	S	SD	T	V	W	WF	GG	R
ø40	7	151.5	14	37	14	74	60	74	98	6	8	ø25	14	ø31	28.5	52	40.5	23	74	13	24	2	48	20	57
ø50	9	173.5	21	31	14	62	67	80	118	6	9	ø30	17	ø38	42.5	54	48	26	90	16	24	2	53	20	69
ø63	15	189	20	45	19	90	85	100	140	7	10	ø35	20	ø38	28	53	59	31	110	18	21	3	63	-	80
ø80	17	215.5	20	53	19	106	106	118	177	10	11	ø40	26	ø43	34.5	64	74	36	142	21	24	2	70	-	98
ø100	22	257	27	62	24	124	132	150	220	12	15	ø50	26	ø51	34	71	90	46	175	27	30	2	87	-	118

● Rod side flange (FA)

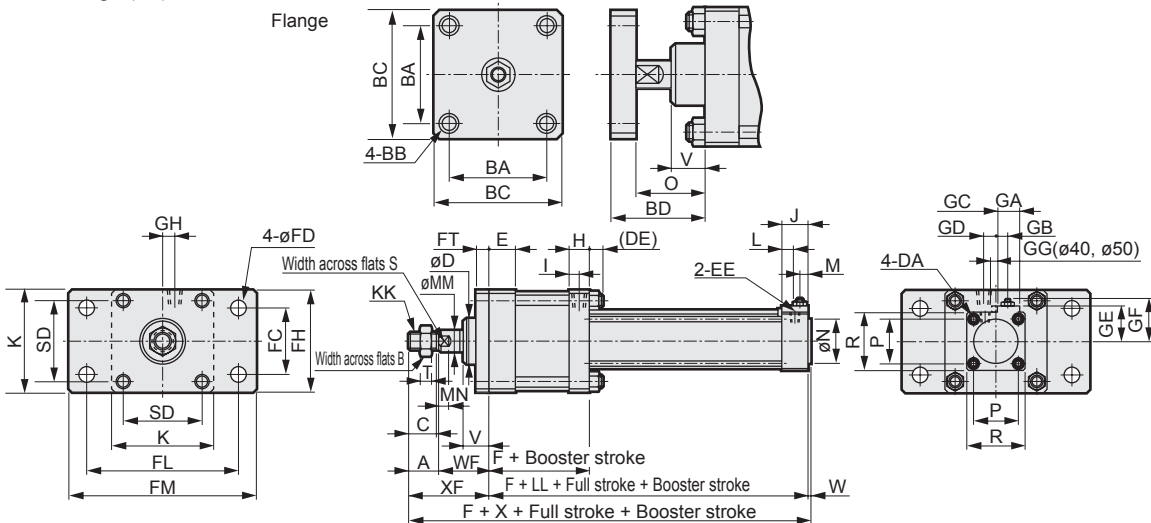

*1 : GG dimension applies to ø40 and ø50.

*2 : For dimensions with bellows, refer to page 1162.

*3 : For the dimensions of the accessories, refer to page 1163.

Bore size (mm)	A	B	BA	BB	BC	BD	C	D	DA	DE	E	EE	F	FC	FD	FH	FL	FM	FT	GA	GB	GC	GD	GE	GF
ø40	36	32	50	M12	74	68	34	ø43	M8	-	35	Rc1/8	84.5	74	14	98	125	153	19	26	4	-	8.5	36.5	47.5
ø50	45	41	60	M12	90	75	43	ø51	M8	-	36	Rc1/4	90.5	88	14	118	144	180	19	30	2	-	10	43	53.5
ø63	50	46	80	M14	110	74	47	ø57	M8	18	33	Rc1/4	90	100	19	140	190	230	14	32	9	1	13	48	58
ø80	56	55	110	M16	142	89	53	ø62.5	M12	20	34	Rc3/8	105	118	19	177	236	280	19	38	8	1	16	59	69
ø100	72	70	130	M20	175	100	69	ø75	M12	24	37	Rc3/8	110.5	150	24	220	280	330	25	41	12.5	5	20	71	81

Bore size (mm)	GH	H	I	J	K	KK	L	LL	M	MM	MN	N	O	P	R	S	SD	T	V	W	WF	X	XF	GG
ø40	12	18	10	26	98	M22x1.5	7	65.5	8	ø25	14	ø31	52	40.5	57	23	74	13	24	2	48	151.5	84	20
ø50	16	22	11.5	32	118	M26x1.5	9	73.5	9	ø30	17	ø38	54	48	69	26	90	16	24	2	53	173.5	98	20
ø63	13	24	13	30	140	M30x1.5	15	73	10	ø35	20	ø38	53	59	80	31	110	18	21	3	63	189	113	-
ø80	15	28	15	34	177	M36x1.5	17	87.5	11	ø40	26	ø43	64	74	98	36	142	21	24	2	70	215.5	126	-
ø100	20	26	13	37	220	M45x1.5	22	96	15	ø50	26	ø51	71	90	118	46	175	27	30	2	87	257	159	-

Dimensions [rod side trunnion (TA)]



● Rod side trunnion (TA)

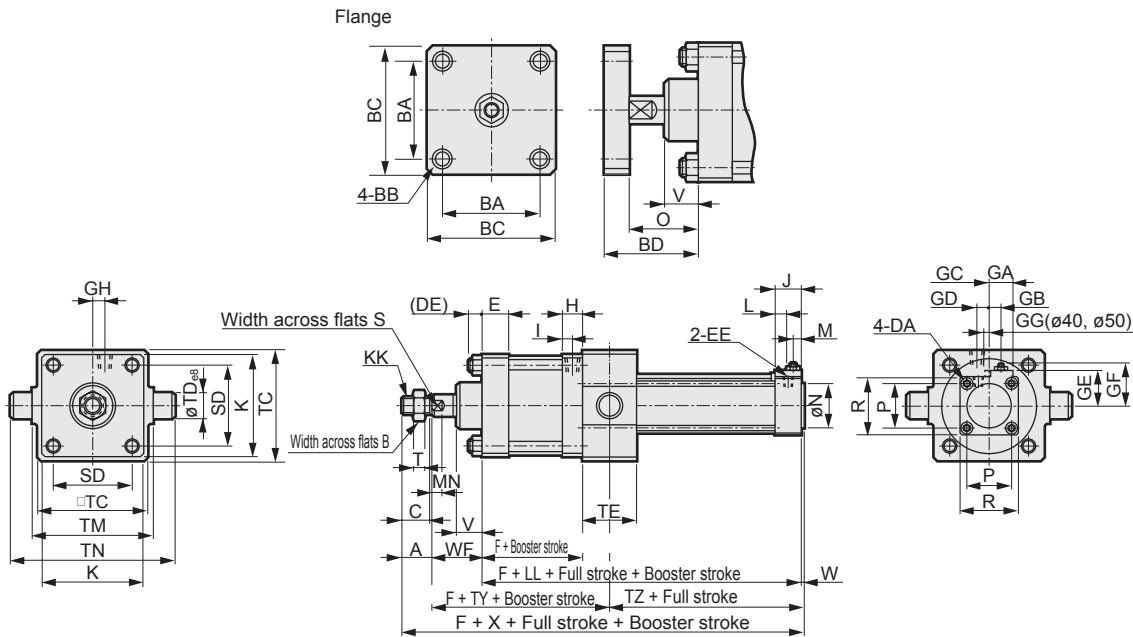

- *1 : GG dimension applies to $\phi 40$ and $\phi 50$.
- *2 : Since it would hit the trunnion, a switch cannot be installed at the forward end.
- *3 : A piping port cannot be attached on the side where the trunnion shaft is protruding out.
- *4 : For dimensions with bellows, refer to page 1162.
- *5 : For the dimensions of the accessories, refer to page 1163.

Bore size (mm)	A	B	BA	BB	BC	BD	C	D	DA	DE	E	EE	F	GA	GB	GC	GD	GE	GF	GH	H	I	J	K	
$\phi 40$	36	32	50	M12	74	68	34	$\phi 43$	M8	-	35	Rc1/8	84.5	26	4	-	8.5	36.5	47.5	12	18	10	26	98	
$\phi 50$	45	41	60	M12	90	75	43	$\phi 51$	M8	-	36	Rc1/4	90.5	30	2	-	10	43	53.5	16	22	11.5	32	118	
$\phi 63$	50	46	80	M14	110	74	47	$\phi 57$	M8	18	33	Rc1/4	90	32	9	1	13	48	58	13	24	13	30	140	
$\phi 80$	56	55	110	M16	142	89	53	$\phi 62.5$	M12	20	34	Rc3/8	105	38	8	1	16	59	69	15	28	15	34	177	
$\phi 100$	72	70	130	M20	175	100	69	$\phi 75$	M12	24	37	Rc3/8	110.5	41	12.5	5	20	71	81	20	26	13	37	220	
Bore size (mm)	KK	L	LL	M	MM	MN	N	O	P	R	S	SD	T	TC	TD	TE	TM	TN	TY	TZ	V	W	WF	X	GG
$\phi 40$	M22x1.5	7	65.5	8	$\phi 25$	14	$\phi 31$	52	40.5	57	23	74	13	100	25	40	115	165	68	47.5	24	2	48	151.5	20
$\phi 50$	M26x1.5	9	73.5	9	$\phi 30$	17	$\phi 38$	54	48	69	26	90	16	121	35	50	135	205	78	50.5	24	2	53	173.5	20
$\phi 63$	M30x1.5	15	73	10	$\phi 35$	20	$\phi 38$	53	59	80	31	110	18	150	32	50	170	234	88	51	21	3	63	189	-
$\phi 80$	M36x1.5	17	87.5	11	$\phi 40$	26	$\phi 43$	64	74	98	36	142	21	190	40	60	212	292	100	59.5	24	2	70	215.5	-
$\phi 100$	M45x1.5	22	96	15	$\phi 50$	26	$\phi 51$	71	90	118	46	175	27	242	45	70	265	355	122	63	30	2	87	257	-

LCM
LCR
LCG
LCW
LCX
STM
STG
STS/STL
STR2
UCA2
ULK*
JSK/M2
JSG
JSC3/JSC4
USSD
UFCD
USC
UB
JSB3
LMB
LML
HCM
HCA
LBC
CAC4
UCAC2
CAC-N
UCAC-N
RCS2
RCC2
PCC
SHC
MCP
GLC
MFC
BBS
RRC
GRC
RV3*
NHS
HRL
LN
Hand
Chuk
MechHnd/Chuk
ShkAbs
FJ
FK
SpdContr
Ending

SHC/SHC-K Series

Booster single control port position dimensions (option)

● SHC (double force)

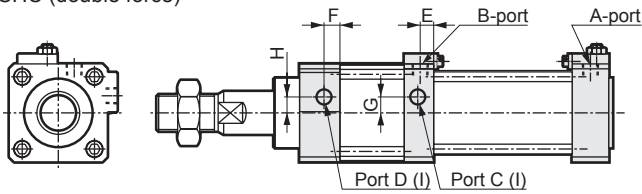

Bore size (mm)	E	F	G	H	2-l
ø40	10	11	10	2	Rc1/8
ø50	11	13	13	5	Rc1/4
ø63	13	17.5	14	9.5	Rc1/4
ø80	14	17	18	12	Rc3/8
ø100	13	19	26	15	Rc3/8

● SHC-TA (rod side trunnion)

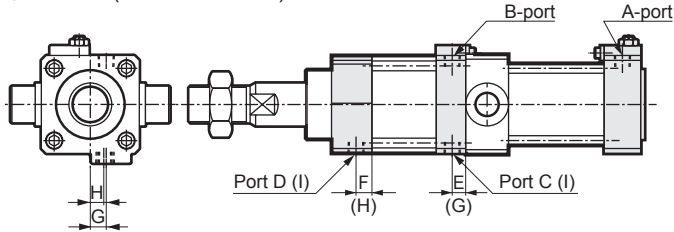

● SHC-FA (rod side flange)

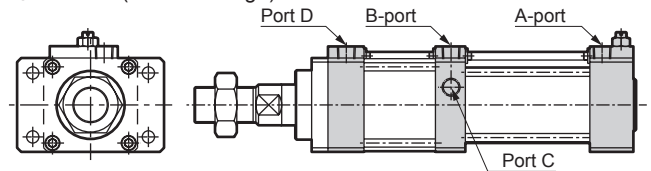

● SHC-K (quad force)

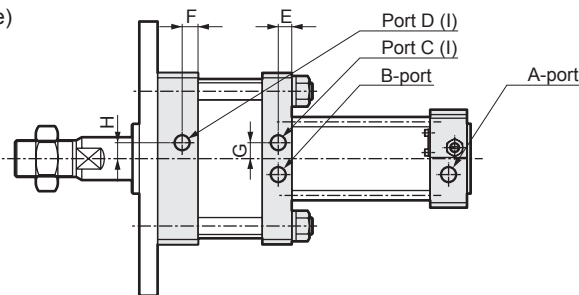

Bore size (mm)	E	F	G	H	2-l
ø40	8	10	6	6	Rc1/8
ø50	10.5	11	6	6	Rc1/4
ø63	13	13	13	13	Rc1/4
ø80	14	14	14	14	Rc3/8
ø100	13	13	21	42	Rc3/8

Dimensions with bellows (common to SHC and SHC-K)

● Standard

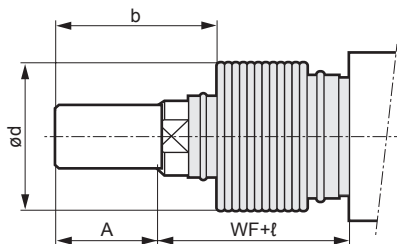

● SHC

Bore size (mm)	A	b	d	WF
ø40	36	51.5	53	42
ø50	45	65	61	47
ø63	50	80	75	55.5
ø80	56	88	80	61
ø100	72	108	95	71

Bore size (mm)	ℓ							
ø40	50 or less	51 to 100	101 to 150	151 to 200	201 to 300	301 to 400	401 to 500	501 or more
	14	26	38	49	72	96	119	(Full stroke/4.3) + 2.5
ø50	50 or less	51 to 100	101 to 150	151 to 200	201 to 300	301 to 400	401 to 500	501 or more
	20	32	42	53	76	98	120	(Full stroke/4.5) + 9
ø63	(Full stroke/4.55) + 11							
ø80	(Full stroke/5.15) + 9							
ø100	(Full stroke/5.3) + 9							

● SHC-K

Bore size (mm)	A	b	d	WF
ø40	36	51.5	53	42
ø50	45	65	61	47
ø63	50	80	75	55.5
ø80	56	88	80	61
ø100	72	108	95	71

Bore size (mm)	ℓ							
ø40	50 or less	51 to 100	101 to 150	151 to 200	201 to 300	301 to 400	401 to 500	501 or more
	14	26	38	49	72	96	119	(Full stroke/4.3) + 2.5
ø50	50 or less	51 to 100	101 to 150	151 to 200	201 to 300	301 to 400	401 to 500	501 or more
	20	32	42	53	76	98	120	(Full stroke/4.5) + 9
ø63	(Full stroke/4.55) + 11							
ø80	(Full stroke/5.15) + 9							
ø100	(Full stroke/5.3) + 9							

● Rod end flange

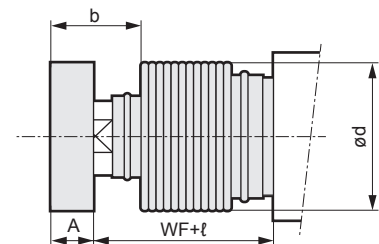

● SHC

Bore size (mm)	A	b	d	WF
ø40	16	35.5	53	46
ø50	21	42	61	48
ø63	21	41	75	45.5
ø80	25	51	80	56
ø100	29	49	95	55

Bore size (mm)	ℓ							
ø40	50 or less	51 to 100	101 to 150	151 to 200	201 to 300	301 to 400	401 to 500	501 or more
	14	26	38	49	72	96	119	(Full stroke/4.3) + 2.5
ø50	50 or less	51 to 100	101 to 150	151 to 200	201 to 300	301 to 400	401 to 500	501 or more
	20	32	42	53	76	98	120	(Full stroke/4.5) + 9
ø63	(Full stroke/4.55) + 11							
ø80	(Full stroke/5.15) + 9							
ø100	(Full stroke/5.3) + 9							

● SHC-K

Bore size (mm)	A	b	d	WF
ø40	16	35.5	53	46
ø50	21	42	61	48
ø63	21	41	75	45.5
ø80	25	51	80	56
ø100	29	49	95	55

Bore size (mm)	ℓ							
ø40	50 or less	51 to 100	101 to 150	151 to 200	201 to 300	301 to 400	401 to 500	501 or more
	14	26	38	49	72	96	119	(Full stroke/4.3) + 2.5
ø50	50 or less	51 to 100	101 to 150	151 to 200	201 to 300	301 to 400	401 to 500	501 or more
	20	32	42	53	76	98	120	(Full stroke/4.5) + 9
ø63	(Full stroke/4.55) + 11							
ø80	(Full stroke/5.15) + 9							
ø100	(Full stroke/5.3) + 9							

Accessory dimensions (rod eye/clevis bracket/pin)

● Rod eye (I)

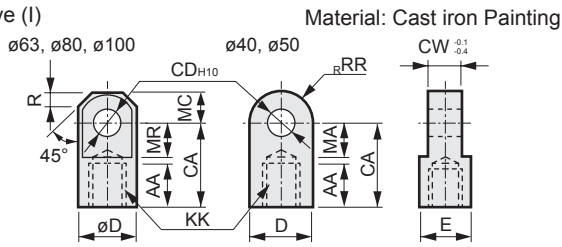

Material: Cast iron Painting

Model No.	Bore size (mm)	AA	CA	CD	CW	D	E	KK	MA	MC	R	RR	Weight (kg)
SHC-I-40	ø40	30	70	20	28	46	41	M22x1.5	30	-	-	25	0.83
SHC-I-50	ø50	30	70	20	28	46	41	M26x1.5	30	-	-	25	0.83
SHC-I-63	ø63	50	85	25	32	55	-	M30x1.5	32	27.5	15.5	-	1.2
SHC-I-80	ø80	60	105	32	40	70	-	M36x1.5	40	35	21	-	2.5
SHC-I-100	ø100	75	125	40	50	85	-	M45x1.5	47.5	42.5	29	-	4.2

● Rod clevis (Y)

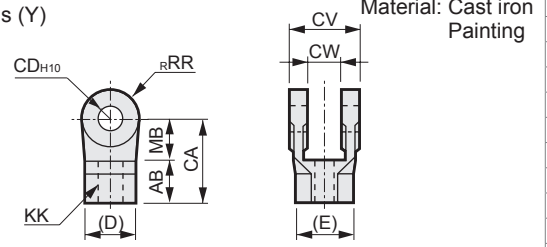

Material: Cast iron Painting

Model No.	Bore size (mm)	AB	CA	CD	CW	CV	D	E	KK	MB	RR	Weight (kg)
SHC-Y-40	ø40	35	70	20	28	56	41	47.3	M22x1.5	30	25	0.7
SHC-Y-50	ø50	35	70	20	28	56	41	47.3	M26x1.5	30	25	0.7
SHC-Y-63	ø63	50	85	25	32	64	46	53.1	M30x1.5	35	27.5	1
SHC-Y-80	ø80	60	105	32	40	80	55	63.5	M36x1.5	45	35	2
SHC-Y-100	ø100	75	125	40	50	100	70	80.8	M45x1.5	50	42.5	3.7

Note: A pin and a snap ring are attached.

A) Second bracket for clevis

● Eye bracket (B11)

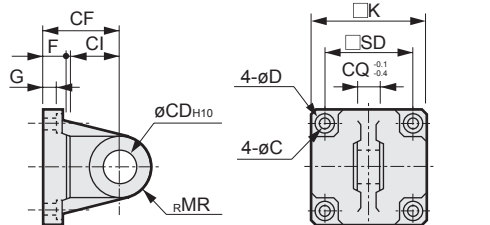

Material: Cast iron Painting

Model No.	Bore size (mm)	C	CD	CF	CI	CQ	D	F	G	K	MR	SD	Weight (kg)
SHC-B11-40	ø40	9	12	32	18	18	14	10	6.5	57	12	40.5	0.27
SHC-B11-50	ø50	9	12	32	18	18	14	10	6.5	66	12	48	0.33
SHC-B11-63	ø63	9	14	37	24	20	14	10	7.5	80	16	59	0.54
SHC-B11-80	ø80	14	20	52	30	28	20	14	10.5	98	20	74	1.3
SHC-B11-100	ø100	14	20	52	30	28	20	16	10.5	118	20	90	1.7

● Clevis bracket (B21)

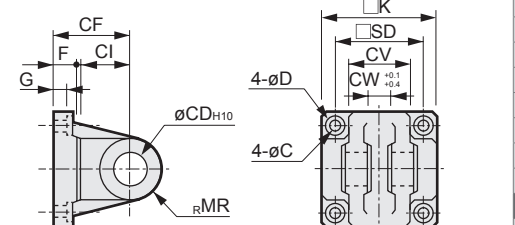

Material: Cast iron Painting

Model No.	Bore size (mm)	C	CD	CF	CI	CV	CW	D	F	G	K	MR	SD	Weight (kg)
SHC-B21-40	ø40	9	12	32	18	36	18	14	10	6.5	57	12	40.5	0.28
SHC-B21-50	ø50	9	12	32	18	36	18	14	10	6.5	66	12	48	0.33
SHC-B21-63	ø63	9	14	37	24	40	20	14	10	7.5	80	16	59	0.53
SHC-B21-80	ø80	14	20	52	30	56	28	20	14	10.5	98	20	74	1.3
SHC-B21-100	ø100	14	20	52	30	56	28	20	16	10.5	118	20	90	1.7

Note: A pin and a snap ring are attached.

B) Second bracket for rod eye

● Eye bracket (B12)

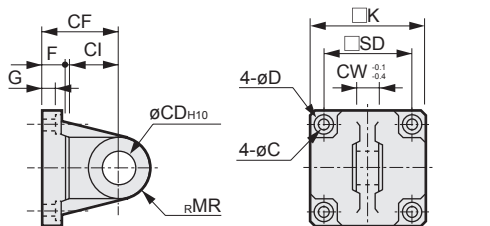

Material: Cast iron Painting

Model No.	Bore size (mm)	C	CD	CF	CI	CW	D	F	G	K	MR	SD	Weight (kg)
SHC-B12-40	ø40	14	20	52	30	28	20	14	10.5	98	20	74	1.3
SHC-B12-50	ø50	14	20	52	30	28	20	16	10.5	118	20	90	1.7
SHC-B12-63	ø63	16	25	63	35	32	23	20	18	140	25	110	2.3
SHC-B12-80	ø80	18	32	75	40	40	26	24	22	174	32	142	4.6
SHC-B12-100	ø100	22	40	90	55	50	32	30	28	220	40	175	8.9

● Clevis bracket (B22)

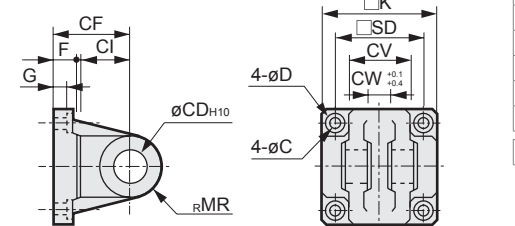

Material: Cast iron Painting

Model No.	Bore size (mm)	C	CD	CF	CI	CV	CW	D	F	G	K	MR	SD	Weight (kg)
SHC-B22-40	ø40	14	20	52	30	56	28	20	14	10.5	98	20	74	1.3
SHC-B22-50	ø50	14	20	52	30	56	28	20	16	10.5	118	20	90	1.7
SHC-B22-63	ø63	16	25	63	35	64	32	23	20	18	140	25	110	2.6
SHC-B22-80	ø80	18	32	75	40	80	40	26	24	22	174	32	142	5
SHC-B22-100	ø100	22	40	90	55	100	50	32	30	28	220	40	175	9.2

Note: A pin and a snap ring are attached.

Clevis pin

● Pin (P)

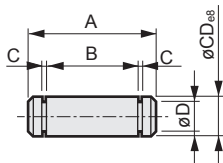

Material: Carbon steel
Zinc chromate treatment

Model No.	Applicable bore size (mm)	A	B	C	D	CD	Applicable snap ring	Weight (kg)
S1-P-40	ø40,50	43.5	36.3	1.15	11.5	12	C type for shaft 12	0.04
S1-P-63	ø63	47.5	40.2	1.15	13.4	14	C type for shaft 14	0.04
S1-P-80	ø80,100	64	56.2	1.35	19	20	C type for shaft 20	0.16

Pin for rod eye

● Pin (P)

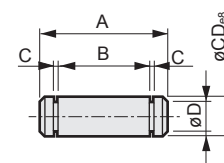

Material: Carbon steel
Zinc chromate treatment

Model No.	Applicable bore size (mm)	A	B	C	D	CD	Applicable snap ring	Weight (kg)
S1-P-80	ø40,50	64	56.2	1.35	19	20	C type for shaft 20	0.16
SCS-125-P	ø63	75	66.3	1.35	23.9	25	C type for shaft 25	0.27
SCS-160-P	ø80	92	82.7	1.65	30.3	32	C type for shaft 32	0.56
SCS-180-P	ø100	115	103.2	1.9	38	40	C type for shaft 40	1.1

- LCM
- LCR
- LCG
- LCW
- LCX
- STM
- STG
- STS/STL
- STR2
- UCA2
- ULK*
- JSK/M2
- JSG
- JSC3/JSC4
- USSD
- UFCD
- USC
- UB
- JSB3
- LMB
- LML
- HCM
- HCA
- LBC
- CAC4
- UCAC2
- CAC-N
- UCAC-N
- RCS2
- RCC2
- PCC
- SHC**
- MCP
- GLC
- MFC
- BBS
- RRC
- GRC
- RV3*
- NHS
- HRL
- LN
- Hand
- Chuk
- MechHnd/Chuk
- ShkAbs
- FJ
- FK
- SpdContr
- Ending

SHC/SHC-K Series

Control circuit

● Standard SHC / SHC-K (circuit 1)

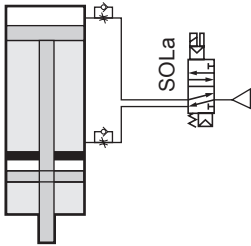

Driven the same as general cylinder.

● Booster single control circuit SHC-A (circuit 2)

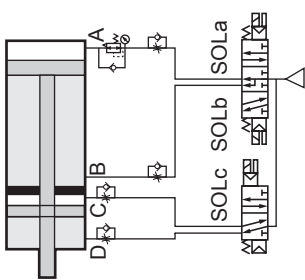

Solenoid valve	Travel stroke		Booster stroke
Operation status	SOLa	SOLb	SOLc
Travel stroke forward	ON	OFF	OFF
Travel stroke end	OFF	OFF	OFF
Standby for 0.1 sec or more	OFF	OFF	OFF
Booster stroke forward	ON	OFF	ON
Booster stroke backward	OFF	OFF	OFF
Standby for 0.1 sec or more	OFF	OFF	OFF
Travel stroke backward	OFF	ON	OFF

(Note) Attach the reverse regulator to the forward side (port A) of the moving cylinder, and vacuum it so that the port A and B sides can be balanced. Otherwise, faulty operation at booster cylinder retraction may result.

● Booster single control circuit SHC-K-A (circuit 3)

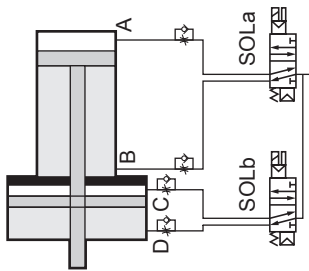

Solenoid valve	Travel stroke		Booster stroke
Operation status	SOLa	SOLb	SOLb
Travel stroke forward	ON	OFF	OFF
Travel stroke end	ON	OFF	OFF
Standby for 0.1 sec or more	ON	OFF	OFF
Booster stroke forward	ON	ON	ON
Booster stroke backward	ON	OFF	OFF
Standby for 0.1 sec or more	ON	OFF	OFF
Travel stroke backward	OFF	OFF	OFF

Booster single control operational diagram

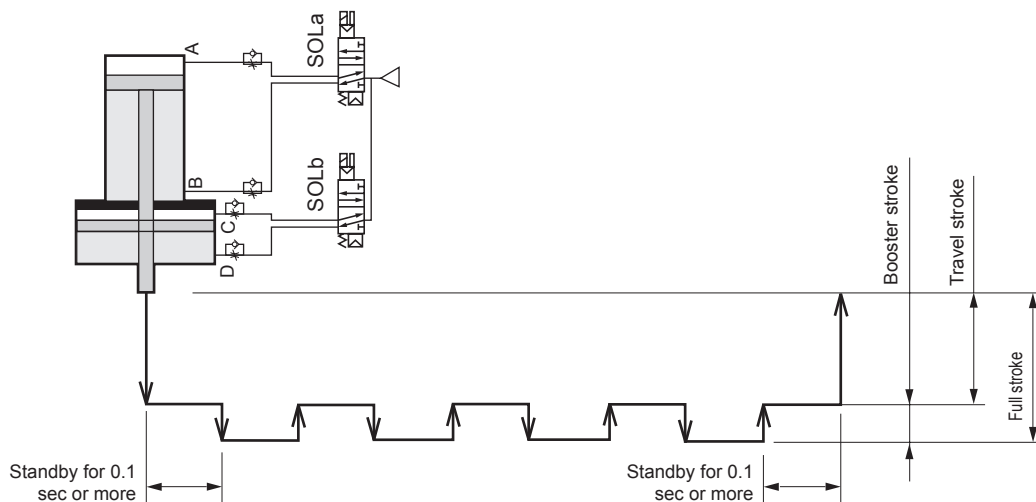

* Selection of solenoid valve is the same as selection of conventional bore size.

*1: When using a manifold, since upward load may allow back pressure from port D to enter port B, use individual exhaust spacers. Or control with a single unit.

Air consumption (in standard condition)

A) For simple reciprocating operation

(1) Air consumption per reciprocation

$$V = Q_1 \times \frac{S_1}{100} + Q_2 \times \frac{S_2}{10}$$

(2) Air consumption per minute

$$Q = V \times N = (Q_1 \times \frac{S_1}{100} + Q_2 \times \frac{S_2}{10}) \times N$$

B) For high frequency operation

(1) Air consumption per reciprocation

$$V = Q_1 \times \frac{S_1}{100} + Q_2 \times \frac{S_2}{10} \times n$$

(2) Air consumption per minute

$$Q = V \times N = (Q_1 \times \frac{S_1}{100} + Q_2 \times \frac{S_2}{10} \times n) \times N$$

V: Air consumption per reciprocation ℓ(ANR)

Q: Air consumption per minute ℓ/min(ANR)

Q₁: Air consumption of travel stroke section (Table 1) ℓ(ANR)

Q₂: Air consumption of booster stroke section (Table 2) ℓ(ANR)

S₁: Full stroke mm

S₂: Booster stroke mm

N: Full stroke reciprocating cycle per minute cpm

n: Number of reciprocations of booster stroke Cycle

LCM
LCR
LCG
LCW
LCX
STM
STG
STS/STL
STR2
UCA2
ULK*
JSK/M2
JSG
JSC3/JSC4
USSD
UFCD
USC
UB
JSB3
LMB
LML
HCM
HCA
LBC
CAC4
UCAC2
CAC-N
UCAC-N
RCS2
RCC2
PCC
SHC
MCP
GLC
MFC
BBS
RRC
GRC
RV3*
NHS
HRL
LN
Hand
Chuk
MechHnd/Chuk
ShkAbs
FJ
FK
SpdContr
Ending

Table 1. Air consumption of movement stroke section (common to SHC and SHC-K)

Bore size (mm)	1 reciprocating air consumption per stroke 100 mm: Q ₁ ℓ (ANR)							
	Working pressure MPa							
	0.2	0.3	0.4	0.5	0.6	0.7	0.8	0.9
ø40	0.60	0.80	1.00	1.20	1.40	1.60	1.80	2.00
ø50	0.96	1.28	1.59	1.91	2.23	2.55	2.87	3.18
ø63	1.57	2.09	2.61	3.13	3.65	4.17	4.69	5.21
ø80	2.62	3.48	4.35	5.22	6.09	6.96	7.83	8.69
ø100	4.09	5.44	6.80	8.16	9.52	10.87	12.23	13.59

Table 2. Air consumption of booster stroke section

Bore size (mm)		1 reciprocating air consumption per stroke 100 mm: Q ₂ ℓ (ANR)							
		Working pressure MPa							
		0.2	0.3	0.4	0.5	0.6	0.7	0.8	0.9
Double force SHC	ø40	0.08	0.11	0.14	0.17	0.20	0.22	0.25	0.28
	ø50	0.14	0.19	0.23	0.28	0.33	0.37	0.42	0.47
	ø63	0.20	0.26	0.33	0.39	0.46	0.52	0.59	0.65
	ø80	0.28	0.38	0.47	0.56	0.66	0.75	0.85	0.94
	ø100	0.42	0.56	0.70	0.84	0.98	1.12	1.26	1.41
Quad force SHC-K	ø40	0.27	0.35	0.44	0.53	0.62	0.71	0.80	0.88
	ø50	0.42	0.56	0.70	0.84	0.98	1.12	1.26	1.40
	ø63	0.66	0.88	1.10	1.33	1.55	1.77	1.99	2.21
	ø80	1.10	1.47	1.83	2.20	2.56	2.93	3.29	3.66
	ø100	1.73	2.30	2.87	3.45	4.02	4.59	5.16	5.74

Example of calculation

Example 1. Simple reciprocating operation

Model No.: SHC-00-63H-300-20

Full stroke S₁ = 300 mm

Booster stroke S₂ = 20 mm

Working pressure = 0.5 MPa

Full stroke reciprocating cycle per minute N = 10 cpm

(1) Air consumption per reciprocation

$$V = 3.13 \times \frac{300}{100} + 0.39 \times \frac{20}{10} = 10.17 \text{ ℓ(ANR)}$$

(2) Air consumption per minute

$$Q = 10.17 \times 10 = 101.7 \text{ ℓ/min(ANR)}$$

Example 2. High frequency operation

Model No.: SHC-00-63H-300-20

Full stroke S₁ = 300 mm

Booster stroke S₂ = 20 mm

Working pressure = 0.5 MPa

Full stroke reciprocating cycle per minute N = 1 cpm

Number of reciprocations of booster stroke n = 10 cycles

(1) Air consumption per reciprocation

$$V = 3.13 \times \frac{300}{100} + 0.39 \times \frac{20 \times 10}{10} = 17.19 \text{ ℓ(ANR)}$$

(2) Air consumption per minute

$$Q = 17.19 \times 1 = 17.19 \text{ ℓ/min(ANR)}$$

SHC/SHC-K Series

- LCM
- LCR
- LCG
- LCW
- LCX
- STM
- STG
- STS/STL
- STR2
- UCA2
- ULK*
- JSK/M2
- JSG
- JSC3/JSC4
- USSD
- UFCD
- USC
- UB
- JSB3
- LMB
- LML
- HCM
- HCA
- LBC
- CAC4
- UCAC2
- CAC-N
- UCAC-N
- RCS2
- RCC2
- PCC
- SHC**
- MCP
- GLC
- MFC
- BBS
- RRC
- GRC
- RV3*
- NHS
- HRL
- LN
- Hand
- Chuk
- MecHnd/Chuk
- ShkAbs
- FJ
- FK
- SpdContr
- Ending

Calculating travel and booster speed relationship

Standard

Code

Sz: Booster speed (mm/s)

Si: Travel speed (mm/s)

a: Coefficient

b: Initial speed (when travel speed is 50 mm/s) (mm/s)

SHC Formula for 0.5 MPa supply pressure

Bore size (mm)	Booster speed formula (mm/s) $Sz = a (Si - 50) + b$ ($50 \leq Si \leq \text{max. travel speed}$)	Max. travel speed (mm/s)	
		0.5 [MPa]	0.9 [MPa]
ø40	$Sz = 0.186(Si - 50) + 7.2$	540	640
ø50	$Sz = 0.173(Si - 50) + 8$	520	620
ø63	$Sz = 0.157(Si - 50) + 9$	510	610
ø80	$Sz = 0.135(Si - 50) + 10.3$	480	570
ø100	$Sz = 0.123(Si - 50) + 11.1$	450	540

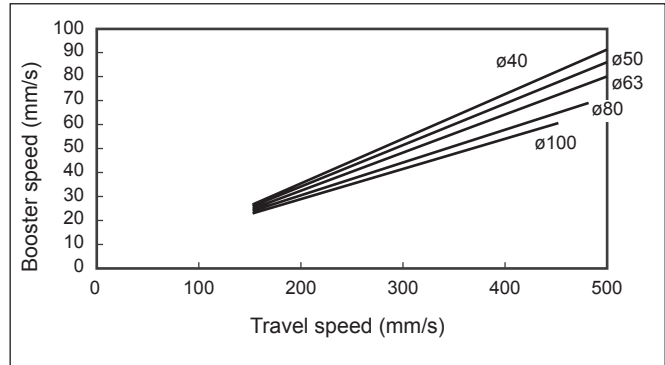

Note that travel and booster speed change about 5% when pressure increases by 0.1 [MPa].

Example of formula

Booster speed to move SHC-00-63H-300-20 cylinder at a pressure of 0.5 [MPa] and travel speed of 500 [mm/s].

With the above formula,

$$Sz = 0.157 \times (500 - 50) + 9 = 79.6 \text{ (mm/s)} \approx 79 \text{ (mm/s)}$$

there will be 5% change at about 0.1 [MPa] at pressure of 0.8 [MPa] and so

$$\text{it will be } Sz' = 1.15 \times Sz = 91.6 \text{ (mm/s)} \approx 91 \text{ (mm/s)}$$

Since the max. travel speed also changes by about 5% as the pressure increases by 0.1 [MPa],

$$\text{it will be } Si_{MAX} = 1.2 \times Si = 612 \text{ (mm/s)} \approx 610 \text{ (mm/s)}$$

The same formula applies when calculating the following.

SHC-K Formula for 0.5 MPa supply pressure

Bore size (mm)	Booster speed formula (mm/s) $Sz = a (Si - 50) + b$ ($50 \leq Si \leq \text{max. travel speed}$)	Max. travel speed (mm/s)	
		0.5 [MPa]	0.9 [MPa]
ø40	$Sz = 0.0149(Si - 50) + 2.3$	540	640
ø50	$Sz = 0.025(Si - 50) + 2.6$	520	620
ø63	$Sz = 0.0381(Si - 50) + 2.9$	510	610
ø80	$Sz = 0.0553(Si - 50) + 3.3$	480	570
ø100	$Sz = 0.0756(Si - 50) + 3.9$	450	540

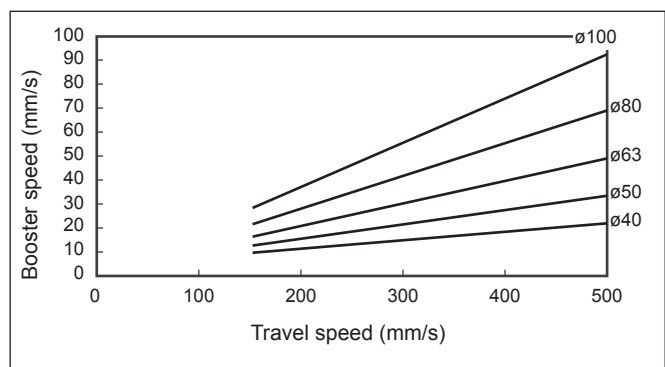

Booster single control

The booster cylinder reciprocates independently, so boosting speed changes with changes in supply pressure.

Code

Sz : Booster speed (mm/s)

P : Pressure (MPa)

c : Coefficient

d : Booster speed coefficient (mm/s)

SHC-A

Bore size (mm)	Booster speed formula (mm/s) Sz = cP + d (0.15 ≤ P ≤ 0.9 [MPa])
ø40	Sz=144P+67.3
ø50	Sz=152.1P+69.8
ø63	Sz=162.7P+73
ø80	Sz=176.6P+77.3
ø100	Sz=193P+82.3

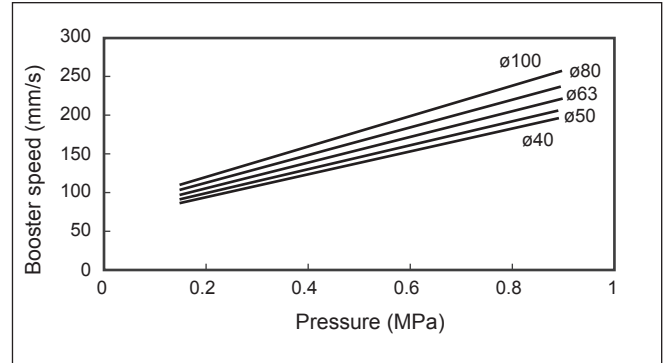

· Example of formula

Booster speed to move SHC-00-40-300-20-A cylinder at pressure of 0.5 [MPa].

With the above formula,

it will be Sz = 144 x 0.5 + 67.3 = 139.3 (mm/s) ≈ 139 (mm/s)

The same formula applies when calculating the following.

SHC-K-A

Bore size (mm)	Booster speed formula (mm/s) Sz = cP + d (0.15 ≤ P ≤ 0.9 [MPa])
ø40	Sz=48.4P+92.6
ø50	Sz=42.7P+85.3
ø63	Sz=35.2P+75.7
ø80	Sz=25.5P+63.2
ø100	Sz=14.1P+48.6

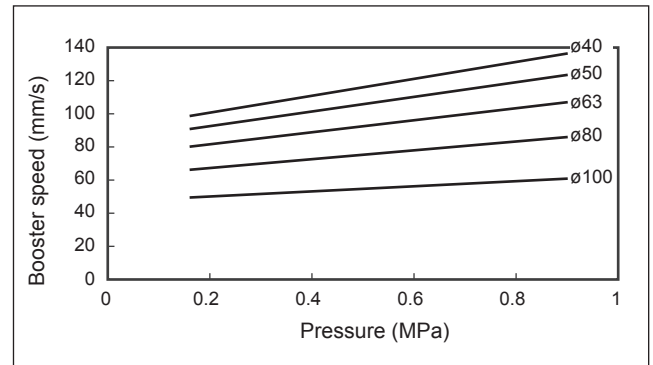

- LCM
- LCR
- LCG
- LCW
- LCX
- STM
- STG
- STS/STL
- STR2
- UCA2
- ULK*
- JSK/M2
- JSG
- JSC3/JSC4
- USSD
- UFCD
- USC
- UB
- JSB3
- LMB
- LML
- HCM
- HCA
- LBC**
- CAC4
- UCAC2
- CAC-N
- UCAC-N
- RCS2
- RCC2
- PCC
- SHC**
- MCP
- GLC
- MFC
- BBS
- RRC
- GRC
- RV3*
- NHS
- HRL
- LN
- Hand
- Chuk
- MechHand/Chuk
- ShkAbs
- FJ
- FK
- SpdContr
- Ending

SHC/SHC-K Series

- LCM
- LCR
- LCG
- LCW
- LCX
- STM
- STG
- STS/STL
- STR2
- UCA2
- ULK*
- JSK/M2
- JSG
- JSC3/JSC4
- USSD
- UFCD
- USC
- UB
- JSB3
- LMB
- LML
- HCM
- HCA
- LBC
- CAC4
- UCAC2
- CAC-N
- UCAC-N
- RCS2
- RCC2
- PCC
- SHC**
- MCP
- GLC
- MFC
- BBS
- RRC
- GRC
- RV3*
- NHS
- HRL
- LN
- Hand
- Chuk
- MecHnd/Chuk
- ShkAbs
- FJ
- FK
- SpdContr
- Ending

Travel speed and time to reach 90% thrust

Standard

Code

t: Time to reach 90% thrust (time to reach 90% thrust after contacting object) (s)

e, e': Coefficient

Si: Travel speed (mm/s)

f, f', f'': Time (s) at travel speed of 50, 100 and 300 mm/s

SHC Formula for 0.5 MPa supply pressure

Bore size (mm)	Formula for time to reach 90% thrust at 50 to 100 mm/s travel speed (s) $t = e (Si-50) + f$ ($50 \leq Si \leq 100$)	Formula for time to reach 90% thrust at 100 mm/s or higher travel speed (s) $t = e (Si-100) + f$ ($100 \leq Si \leq \text{max. travel speed}$)	Max. travel speed (mm/s)
ø40	$t = -0.0146(Si-50) + 2.1$	$t = -0.00167(Si-100) + 1.37$	540
ø50	$t = -0.013(Si-50) + 2.05$	$t = -0.0013(Si-100) + 1.4$	520
ø63	$t = -0.013(Si-50) + 1.93$	$t = -0.00125(Si-100) + 1.35$	510
ø80	$t = -0.0118(Si-50) + 1.93$	$t = -0.000934(Si-100) + 1.34$	480
ø100	$t = -0.0104(Si-50) + 1.85$	$t = -0.0005625(Si-100) + 1.33$	450

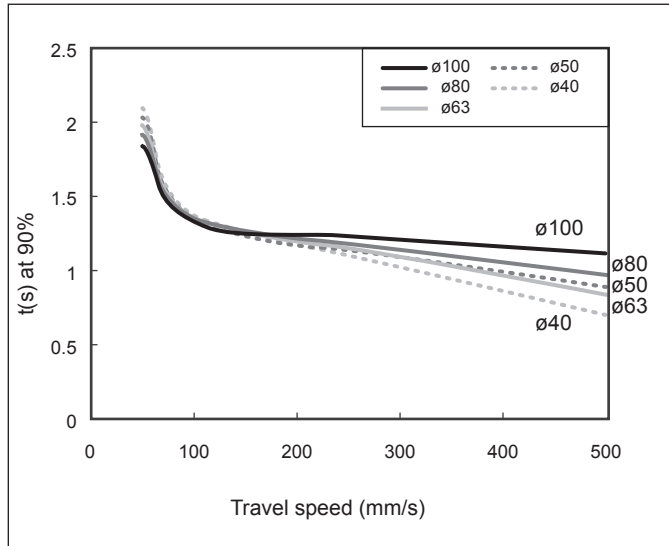

Note that the time to reach 90% thrust takes about 5 to 10% longer when supply pressure rises by 0.1 [MPa]. The max. travel speed increases about 5% when pressure rises by 0.1 [MPa].

· Example of calculation

Time to reach 90% thrust when SHC-00-63H-300-20 cylinder is moved at a pressure of 0.5 [MPa] and travel speed of 500 [mm/s].

With the above formula,

$$t = -0.00125 \times (500-100) + 1.35 = 0.85 \text{ (s)} \approx 0.8 \text{ (s)}$$

Since there is a 5 to 10% change at about 0.1 [MPa] at pressure of 0.8 [MPa],

$$t' = (1.15 \text{ to } 1.3) t = 0.98 \text{ to } 1.1 \text{ (s)} \approx 1.0 \text{ (s)}$$

is a guideline. When using the double force, time is not varied much by the full stroke. The K (quad force) below has a separate functional expression because the time to attain thrust differs slightly with the full stroke (full stroke < 300 and full stroke ≥ 300). The time for the booster stroke 10 [mm] and 20 [mm] does not vary much.

SHC-K Formula for 0.5 MPa supply pressure

· Full stroke < 300 mm

Bore size (mm)		Formula for time to reach 90% thrust at 50 to 100 mm/s travel speed (s) $t = e (Si-50) + f$ ($50 \leq Si \leq 100$)	Formula for time to reach 90% thrust at 100 to 300 mm/s travel speed (s) $t = e (Si-100) + f$ ($100 \leq Si \leq \text{max. travel speed}$)	Formula for time to reach 90% thrust at 300 mm/s or higher travel speed (s) $t = e'' (Si-300) + f''$ ($300 \leq Si \leq \text{max. travel speed}$)	Max. travel speed (mm/s)
ø40	Note	$t = -0.094(Si-50) + 8.7$	$t = -0.014(Si-100) + 4$	$t = -0.0034(Si-300) + 1.2$	540
ø50		$t = -0.1(Si-50) + 8.9$	$t = -0.01(Si-100) + 3.9$	$t = -0.00078(Si-300) + 1.9$	520
ø63		$t = -0.095(Si-50) + 8.51$	$t = -0.009885(Si-100) + 3.76$	$t = -0.0011(Si-300) + 1.783$	510
ø80		$t = -0.0886(Si-50) + 8$	$t = -0.0097(Si-100) + 3.57$	$t = -0.00152(Si-300) + 1.63$	480
ø100		$t = -0.081(Si-50) + 7.4$	$t = -0.0095(Si-100) + 3.35$	$t = -0.002(Si-300) + 1.45$	450

Note For SHC-K-40 only, when travel speed is 500 [mm/s] and over, there is almost no time variation until thrust attains 90%.

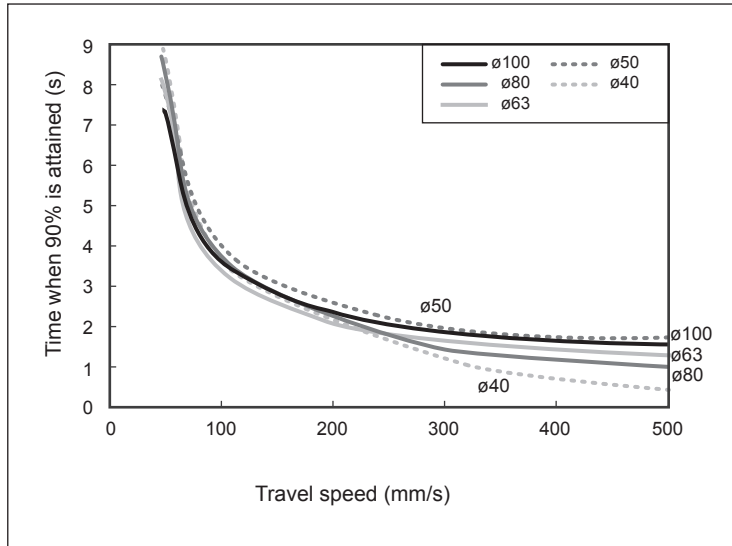

· Full stroke ≥ 300 mm

Bore size (mm)		Formula for time to reach 90% thrust at 50 to 100 mm/s travel speed (s) $t = e (Si-50) + f$ ($50 \leq Si \leq 100$)	Formula for time to reach 90% thrust at 100 to 300 mm/s travel speed (s) $t = e (Si-100) + f$ ($100 \leq Si \leq \text{max. travel speed}$)	Formula for time to reach 90% thrust at 300 mm/s or higher travel speed (s) $t = e'' (Si-300) + f''$ ($300 \leq Si \leq \text{max. travel speed}$)	Max. travel speed (mm/s)
ø40	Note	$t = -0.049(Si-50) + 5.15$	$t = -0.00925(Si-100) + 2.7$	$t = -0.0017(Si-300) + 0.85$	540
ø50		$t = -0.051(Si-50) + 5.21$	$t = -0.0063(Si-100) + 2.66$	$t = -0.00039(Si-300) + 1.4$	520
ø63		$t = -0.0484(Si-50) + 4.98$	$t = -0.0062(Si-100) + 2.56$	$t = -0.000548(Si-300) + 1.32$	510
ø80		$t = -0.045(Si-50) + 4.68$	$t = -0.00612(Si-100) + 2.43$	$t = -0.000765(Si-300) + 1.206$	480
ø100		$t = -0.041(Si-50) + 4.33$	$t = -0.006(Si-100) + 2.28$	$t = -0.001(Si-300) + 1.08$	450

Note For SHC-K-40 only, when travel speed is 500 [mm/s] and over, there is almost no time variation until thrust attains 90%.

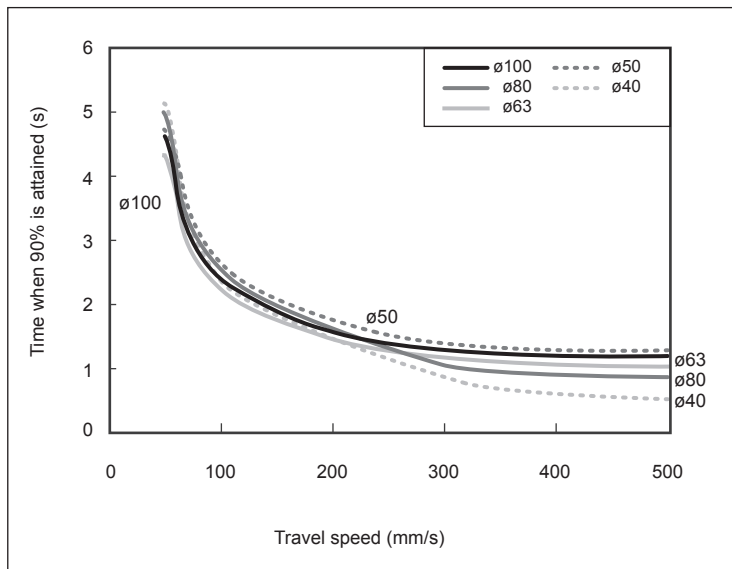

- LCM
- LCR
- LCG
- LCW
- LCX
- STM
- STG
- STS/STL
- STR2
- UCA2
- ULK*
- JSK/M2
- JSG
- JSC3/JSC4
- USSD
- UFCD
- USC
- UB
- JSB3
- LMB
- LML
- HCM
- HCA
- LBC
- CAC4
- UCAC2
- CAC-N
- UCAC-N
- RCS2
- RCC2
- PCC
- SHC**
- MCP
- GLC
- MFC
- BBS
- RRC
- GRC
- RV3*
- NHS
- HRL
- LN
- Hand
- Chuk
- MechHnd/Chuk
- ShkAbs
- FJ
- FK
- SpdContr
- Ending

SHC/SHC-K Series

- LCM
- LCR
- LCC
- LCW
- LCX
- STM
- STG
- STS/STL
- STR2
- UCA2
- ULK*
- JSK/M2
- JSG
- JSC3/JSC4
- USSD
- UFCD
- USC
- UB
- JSB3
- LMB
- LML
- HCM
- HCA
- LBC
- CAC4
- UCAC2
- CAC-N
- UCAC-N
- RCS2
- RCC2
- PCC
- SHC**
- MCP
- GLC
- MFC
- BBS
- RRC
- GRC
- RV3*
- NHS
- HRL
- LN
- Hand
- Chuk
- MechHnd/Chuk
- ShkAbs
- FJ
- FK
- SpdContr
- Ending

Booster single control

Individually reciprocating booster cylinder part varies the time until thrust is generated by supply pressure. The time until thrust generated applies only to the booster cylinder section.

Code

t: Time to reach 90% thrust (time to reach 90% thrust after contacting object) (s)

G: Coefficient

P: Pressure (MPa)

H: Time coefficient (s) until thrust attains 90%

SHC-A

Bore size (mm)	Formula for time to reach 90% thrust (s) $t = GP + H$ ($0.15 \leq P \leq 0.9$ [MPa])
ø40	$t = 0.05P + 0.123$
ø50	$t = 0.0826P + 0.135$
ø63	$t = 0.125P + 0.1525$
ø80	$t = 0.18P + 0.174$
ø100	$t = 0.245P + 0.2$

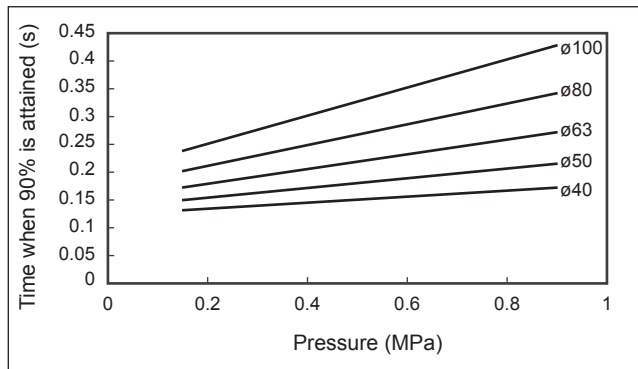

Example of calculation

Time to reach 90% thrust when SHC-00-63H-300-20-A cylinder is moved at a pressure of 0.5 [MPa].

With the above formula,

it will be $t = 0.125 \times 0.5 + 0.1525 = 0.215$ (s) ≈ 0.2 (s)

The time for the booster stroke 10 [mm] and 20 [mm] does not vary much.

The same formula applies when calculating the following.

SHC-K-A

Bore size (mm)	Formula for time to reach 90% thrust (s) $t = GP + H$ ($0.15 \leq P \leq 0.9$ [MPa])
ø40	$t = 0.11P + 0.165$
ø50	$t = 0.121P + 0.172$
ø63	$t = 0.135P + 0.181$
ø80	$t = 0.153P + 0.193$
ø100	$t = 0.175P + 0.2075$

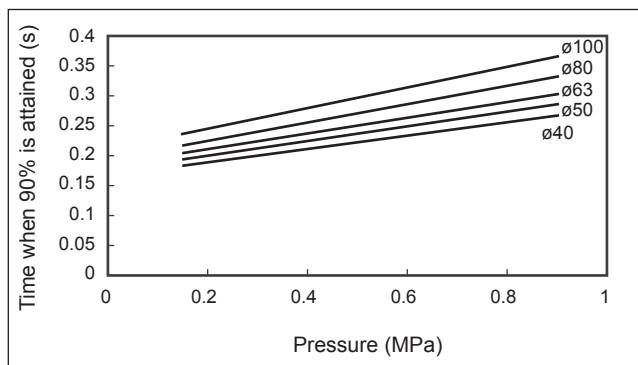

Theoretical thrust formula

SHC pressurized area table

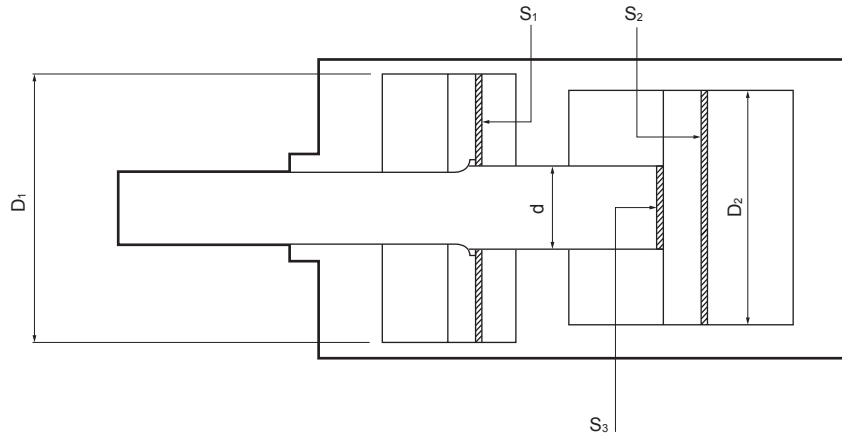

● SHC

Bore size (mm)	S ₁ [cm ²]	S ₂ [cm ²]	S ₃ [cm ²]	D ₁ [mm]	D ₂ [mm]	d [mm]
ø40	13.4	12.5	6.15	ø50	ø40	ø28
ø50	23.1	19.6	8.04	ø63	ø50	ø32
ø63	31.6	31.1	12.5	ø75	ø63	ø40
ø80	43.9	50.2	19.6	ø90	ø80	ø50
ø100	66.7	78.5	28.2	ø110	ø100	ø60

● SHC-K

Bore size (mm)	S ₁ [cm ²]	S ₂ [cm ²]	S ₃ [cm ²]	D ₁ [mm]	D ₂ [mm]	d [mm]
ø40	44.1	12.5	6.15	ø80	ø40	ø28
ø50	70.4	19.6	8.04	ø100	ø50	ø32
ø63	110.1	31.1	12.5	ø125	ø63	ø40
ø80	181.4	50.2	19.6	ø160	ø80	ø50
ø100	285.8	78.5	28.2	ø200	ø100	ø60

$$S_1 = \frac{\pi}{4} (D_1^2 - d^2) \quad S_2 = \frac{\pi}{4} D_2^2 \quad S_3 = \frac{\pi}{4} d^2$$

Formula

Theoretical thrust = low thrust (booster section) effective cross-sectional area * air pressure

Example: Theoretical thrust when a ø63 cylinder is operated at 0.5 [MPa]

· Theoretical thrust of thrust section for push

$$F = S_2 P = 31.1 (\text{cm}^2) \times 10^{-4} \times 0.5 (\text{MPa}) \times 10^6 = 1558 (\text{N})$$

· Theoretical thrust of booster section for push

$$F = (S_1 + S_2) P = (31.6 + 31.1) (\text{cm}^2) \times 10^{-4} \times 0.5 (\text{MPa}) \times 10^6 = 3139 (\text{N})$$

· Theoretical thrust of thrust section for pull

$$F = (S_2 - S_3) P = (31.1 - 12.5) (\text{cm}^2) \times 10^{-4} \times 0.5 (\text{MPa}) \times 10^6 = 930 (\text{N})$$

· Theoretical thrust of booster section for pull

$$F = \{S_1 + (S_2 - S_3)\} P = \{31.6 + (31.1 - 12.5)\} (\text{cm}^2) \times 10^{-4} \times 0.5 (\text{MPa}) \times 10^6 = 2511 (\text{N})$$

Below decimal point is rounded up.

LCM
LCR
LCG
LCW
LCX
STM
STG
STS/STL
STR2
UCA2
ULK*
JSK/M2
JSG
JSC3/JSC4
USSD
UFCD
USC
UB
JSB3
LMB
LML
HCM
HCA
LBC
CAC4
UCAC2
CAC-N
UCAC-N
RCS2
RCC2
PCC
SHC
MCP
GLC
MFC
BBS
RRC
GRC
RV3*
NHS
HRL
LN
Hand
Chuk
MechHnd/Chuk
ShkAbs
FJ
FK
SpdContr
Ending

Pneumatic components



Safety Precautions

Be sure to read this section before use.

Refer to Intro Page 73 for general information of the cylinder, and to Intro Page 80 for general information of the cylinder switch.

Product-specific cautions: High power cylinder SHC Series

Design/selection

⚠ WARNING

■ Intermediate stop

Do not use it for braking due to its structure. The stopping position will become extremely unstable.

⚠ CAUTION

■ Use within the max. stroke.

■ Do not use an ABR port connection solenoid valve for the independent control of the booster.

B and D port passages are connected in the cylinder when the booster cylinder retracts, so air is exhausted from the R port of the solenoid valve.

■ Set the boosted stroke at a position exceeding the dead zone below.

Using it at the dead zone stroke may compromise the thrust of the booster.

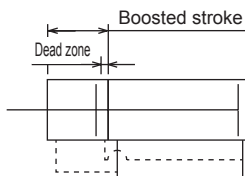

Refer to boosted stroke dead zone dimensions on pages 1144 and 1154.

■ Use discrete solenoid valves in the booster control single circuit. Also, use a separate exhaust spacer when embedding it to a manifold.

The booster port exhaust may flow into the travel port and cause operation faults.

■ Provide a lag of 0.1 seconds or longer at the movement stroke end in the independent control of the booster.

If A and C ports are pressurized simultaneously, the booster piston and coupling collar cannot be connected and will lead to malfunctions. When operating, pressurize A port, then provide a 0.1 second or longer lag at the travel stroke limit before pressurizing the C port.

■ Do not allow a supply pressure differential between port B side and ports C and D side in the independent control of the booster.

Otherwise, disrupted air flow may cause malfunctions. Consult with CKD if a pressure difference must be set.

■ Select in consideration of impact at the time of cylinder coupling.

Due to the product structure, impact is generated when the booster piston and coupling collar connect. Take impact into consideration when designing the equipment. Consult with CKD because the impact value differs with working conditions.

Bore size	Impact value (m/s ²)
ø40	147
ø50	147
ø63	147
ø80	196
ø100	196

■ Note that thrust differs when the boosted stroke cylinder is advancing and retracting.

When the booster starts to retract, a thrust equivalent to double or 4-fold is applied. However, due to the product structure, the thrust is about 70% of the theoretical thrust during travel. Note that the dead zone stroke may compromise the booster thrust in both advancing and retracting.

■ Do not apply an eccentric load to the piston rod.

The booster piston and connecting collar cannot be connected and will lead to malfunctions due to the structure. Be sure to provide guides, floating fittings and the like so as to prevent eccentric load from being applied.

■ Mount a speed controller on the cylinder.

If each cylinder is used at a speed exceeding the working piston speed, correct coupling is not possible and operation faults may occur.

In addition, contact CKD if the load factor is high as inertia may cause the load to reach the end of the force-increasing stroke and strike the workpiece.

■ Do not use multiple synchronized cylinders.

The booster piston and connecting collar cannot be connected and will lead to malfunctions.

■ Note that the piston rod may pop out when decoupling the cylinder.

When using the cylinder with the rod facing upward, if the load factor for the rapid feed section thrust is high, the back pressure of the rapid feed section will decrease when the coupling is released when the rod is lowered, possibly causing the popping out phenomenon. With a high load factor, use of the independent control of the booster “-A” is recommended.

■ Do not apply a reaction force on the piston rod during the travel stroke.

The booster piston and connecting collar cannot be connected and will lead to malfunctions due to the structure.

- LCM
- LCR
- LCC
- LCW
- LCC
- STM
- STG
- STS/STL
- STR2
- UCA2
- ULK*
- JSK/M2
- JSG
- JSC3/JSC4
- USSD
- UFCD
- USC
- UB
- JSB3
- LMB
- LML
- HCM
- HCA
- LBC
- CAC4
- UCAC2
- CAC-N
- UCAC-N
- RCS2
- RCC2
- PCC
- SHC
- MCP
- GLC
- MFC
- BBS
- RRC
- GRC
- RV3*
- NHS
- HRL
- LN
- Hand
- Chuk
- MecHnd/Chuk
- ShkAbs
- FJ
- FK
- SpdContr
- Ending

- Allow a sufficient margin for the supply pressure with respect to the load weight at the end.

If the load at the end is heavier than the supply pressure, faulty connection release or popping out could occur. For the load weight at the end, use the weight equal to or less than the theoretical thrust of PULL PUSH for the rapid feed section when the rod is facing downward and -0.25MPa for the rapid feed section when the rod is facing upward. With a high load factor, use of the independent control of the booster “-A” is recommended.

Mounting, installation and adjustment

⚠ WARNING

- Do not apply load to the pass-pipe. Otherwise, air to the boosted stroke passes through and may prevent the boosted stroke cylinder from operating.



LCM
LCR
LCG
LCW
LCX
STM
STG
STS/STL
STR2
UCA2
ULK*
JSK/M2
JSG
JSC3/JSC4
USSD
UFCD
USC
UB
JSB3
LMB
LML
HCM
HCA
LBC
CAC4
UCAC2
CAC-N
UCAC-N
RCS2
RCC2
PCC
SHC
MCP
GLC
MFC
BBS
RRC
GRC
RV3*
NHS
HRL
LN
Hand
Chuk
MechHnd/Chuk
ShkAbs
FJ
FK
SpdContr
Ending