



To Use This Product Safely

Be sure to read this before use.

Individual Precautions: Cylinders Switch

Design / Selection

Warning

Using outside the specified range of application, load current, voltage, temperature, impact, environment, etc. may cause damage or malfunction. Therefore, use correctly within the specified range.

Never use in an explosive gas atmosphere. The cylinder switch does not have an explosion-proof structure. If used in an explosive gas atmosphere, it may cause an explosion disaster, so never use it.

CAUTION

Please be careful when using in an interlock circuit.

When using a cylinder switch for an interlock signal that requires high reliability, please implement a double interlock system, such as providing a mechanical protection function in case of failure, or using another switch (sensor) in addition to the cylinder switch. In addition, please perform regular inspections and confirm that it operates normally.

Please pay attention to the contact capacity.

Do not use a load that exceeds the voltage and current of the switch specifications. This will cause a malfunction.

Please pay attention to the contact protection circuit. (Reed switch)

When connecting and using inductive loads (relays, solenoid valves, etc.), surge voltage will occur when the switch is OFF, so always install a contact protection circuit.

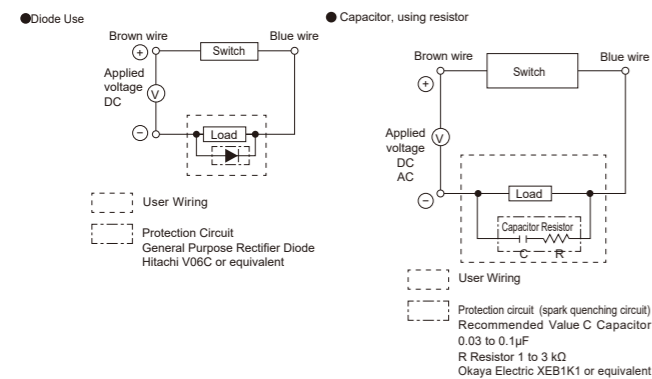

When connecting and using capacitive loads (capacitors), inrush current will occur when the switch is ON, so always install a contact protection circuit.

If the wiring becomes long, it becomes a wiring capacitance, and inrush current occurs, causing damage to the switch or reduction in lifespan. Therefore, if the wiring length exceeds Table 1, install a contact protection circuit. When T8 is used with 200 VAC, the usable wiring length will be shorter, so please consult us.

Switch	Voltage	Wiring length
M, T, K, H, V, F, ET0 type	DC	50 m
M, T, K, H, V, ET0 type	AC	10 m
R0, 5, 6, E0 type	DC	100 m
R0, 5, E0 type	AC	10 m
R4 type	AC	50 m

Table 1

Choke Coil Use

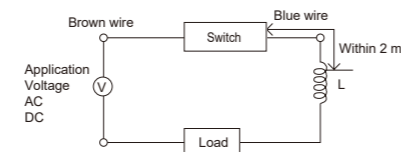

Choke Coil L = Several hundred μH to several mH With excellent high-frequency characteristics

Resistor Use

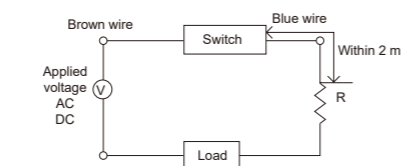

Inrush current limiting resistor R = Resistance as large as the load circuit allows

For specifications of the contact protection circuit, see P. 1487.

Avoid using in environments where water is constantly splashing.

It may cause a malfunction due to insulation failure, etc.

Avoid using in oily or chemical environments.

Using in environments with various oils, coolants, cleaning solutions, or chemicals may adversely affect the cylinder switch (insulation failure, malfunction due to swelling of potting resin, hardening of lead wire coating, etc.), so please consult us.

Coolant proof cylinder switch is available separately. Guide to pneumatic components compatible with coolants" (No. CC-N-375) is available for details.

Do not use in environments with large impacts.

For reed switches, if a large impact (294 m/s² or more) is applied during use, there is a possibility of malfunction where the contact momentarily (1 ms or less) connects or disconnects. It may also be necessary to use a solid state switch depending on the operating environment, so please consult us.

Do not use in locations where surge sources exist.

If there is equipment that generates large surges (electromagnetic lifters, high-frequency induction furnaces, motors, etc.) around the cylinder with a solid state switch, it may cause deterioration or damage to the switch internal circuit elements, so consider surge countermeasures at the source.

Be careful about the accumulation of iron powder and close proximity to magnetic materials.

If a large amount of iron powder such as cutting chips or welding spatter accumulates around a cylinder with a cylinder switch, or if a magnetic material (something attracted to a magnet) is in close contact, the magnetic force within the cylinder may be lost, potentially causing the cylinder switch to stop operating. Please be careful.

Pay attention to the proximity of cylinders, etc.

When using 2 or more cylinders with switches in close proximity and parallel, use them at the allowable cylinder tube spacing indicated for each cylinder series. The switches may malfunction due to mutual magnetic interference.

Pay attention to the magnetic environment.

In environments with strong magnetic fields or large currents (large magnets, spot welding machines, etc.), use strong magnetic field resistant switches. (H0,H0Y,T2YD) When a magnetic material moves very close to the cylinder, mutual interference may occur, potentially affecting detection accuracy.

At the stroke intermediate position, pay attention to the ON time of the cylinder switch.

If the cylinder switch is set at the stroke intermediate position and the load is driven when the piston passes, if the speed is too high, the cylinder switch will operate, but the operating time will be short, and the load may not be able to respond completely, so please be careful. The maximum detectable piston speed is

$$V \text{ (mm/s)} = \frac{\text{Cylinders Switch Operating Range (mm)}}{\text{Load Operating Time (s)}}$$

If the piston speed is high, please use an off-delay output type cylinder switch T2JH/V (limited to compatible models).

Be careful with series connection methods.

When connecting multiple 2-wire switches in series, the voltage drop across the switches is the sum of the voltage drops of all connected switches. The voltage applied to the load side will be the power supply voltage minus the voltage drop across the switches. Check the load specifications before deciding on the number of units to connect.

If 2-wire solid-state switches are connected in series, there is a possibility of malfunction, so please contact us. Use with reed switches is recommended.

When connecting multiple 3-wire solid-state switches in series, the voltage drop across the switches is the sum of the voltage drops of all connected switches, similar to the 2-wire type. Also, the current flowing through the switches will be the sum of the current consumption of the connected switches and the load current, as shown in the upper right diagram. Check the load specifications to ensure the maximum load current of the switch is not exceeded before deciding on the number of units to connect.

The indicator lamp will only light up when all switches are ON.

Figure 1: R3 (Y), M3 (W), T3 (Y), K3 (Y), F3 (Y)

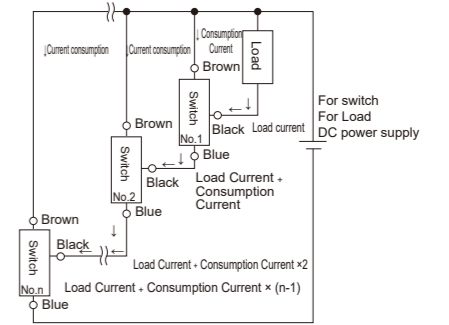

For T3P, K3P, M3P

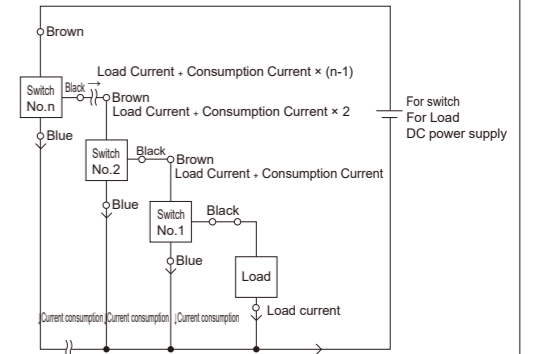

Be careful with parallel connection methods.

When connecting multiple 2-wire switches in parallel, the leakage current increases by the number of connected units. Therefore, confirm the load specifications and decide the number of connected units.

For 2-wire solid-state switches, from the time one switch turns ON until it turns OFF, the voltage across the terminals of parallel-connected switches drops to the internal voltage drop value when the switch is ON, falling below the load voltage range, so other switches will not turn ON. Therefore, check the input specifications of the connected load, such as a programmable controller, before use.

For 3-wire solid-state switches, the leakage current is very small (10 μA or less), so there is no problem in normal use.

The indicator lamp of the switch may become dim or not light up.

■ Output Circuit Protection (Solid State Switch)

- When connecting and using inductive loads (relays, solenoid valves, etc.), surge voltage will occur when the switch is OFF, so always install a protection circuit as shown in the figure below.

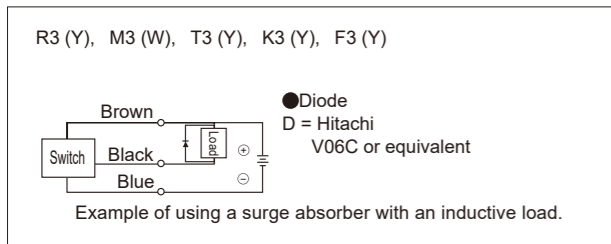
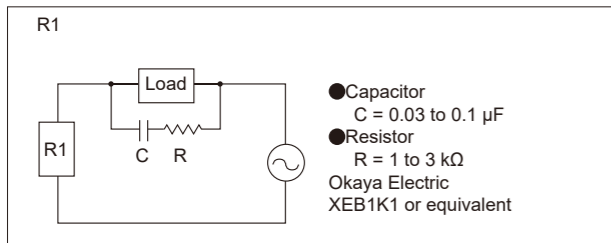

- When connecting and using capacitive loads (capacitors), inrush current will occur when the switch is ON, so always install a protection circuit as shown in the figure below.

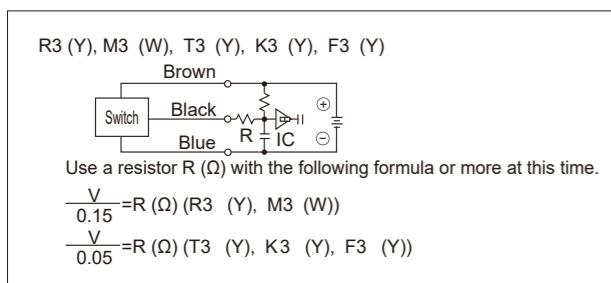

- If the lead wire length exceeds 10 m, always install a protection circuit as shown in the figure below.

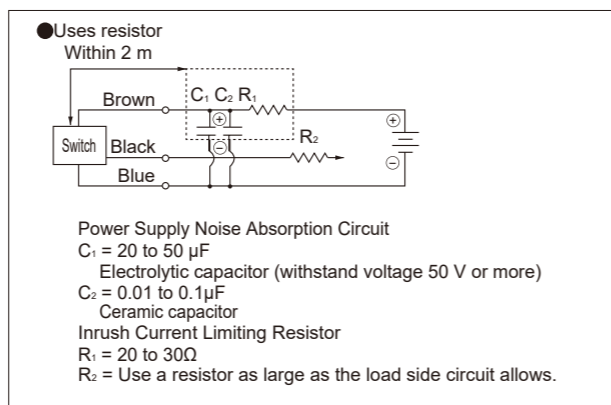
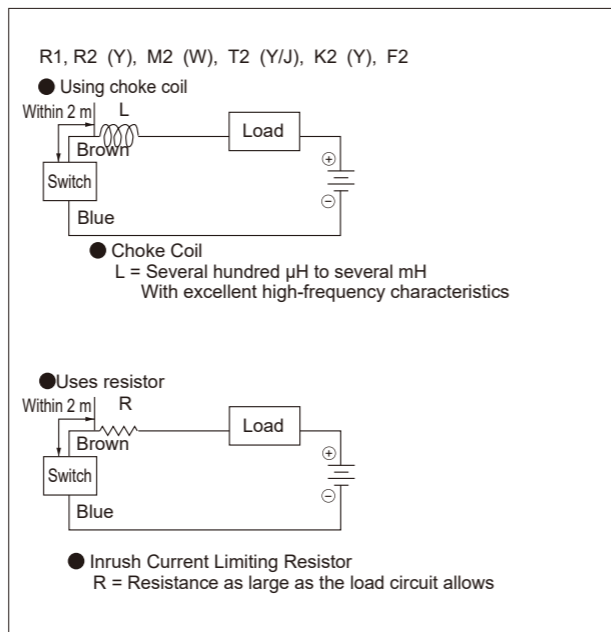

■ Be careful about the lifespan of reed switches.

- The lifespan of reed switches varies depending on usage conditions, but is generally several million cycles. If the equipment used operates continuously day and night or at high frequency, the contact life region will be reached in a short period, so use solid state switches without contact parts.

- If special quality and reliability are required, such as when using with a customer-dedicated circuit board, a proximity switch is recommended. In addition, please be sure to thoroughly check the compatibility judgment by yourself.

During Use

⚠ CAUTION

■ Do not drop or strike.

When handling, do not drop, strike, or apply excessive impact (reed switch 294 m/s² or more, solid state switch 980 m/s² or more). Even if the switch case body is not damaged, the switch internals may be damaged, potentially leading to malfunction.

■ Do not carry the cylinder by the switch's lead wire.

This can not only cause lead wire breakage, but also apply stress to the inside of the switch, potentially damaging internal switch elements. Absolutely do not do this.

■ Do not use the same wiring as power lines or high-voltage lines.

Avoid parallel wiring or using the same conduit as power lines/high-voltage lines; use separate wiring. Control circuits including cylinder switches may malfunction due to noise.

■ Do not short-circuit the load.

If turned ON in a load short-circuited state, overcurrent will flow and the switch will be instantaneously damaged.

■ Be careful when connecting lead wires.

Turn off the power to the equipment on the connected electrical circuit side before performing wiring work. Working with the power on can cause electric shock or accidents due to unexpected operation.

● Reed switch

Do not connect the switch lead wires directly to the power supply; always connect a load in series. Also, for RO, MO, TO, KO, EO, FO, ETO, please also pay attention to ① and ② below.

① When using for DC, connect so that the brown wire is the + side and the blue wire is the - side. If connected in reverse, the switch will operate, but the indicator light will not turn on. (HO has no polarity.)

② When connecting to an AC relay or programmable controller input, if those circuits perform half-wave rectification, the indicator light may not light up. In that case, reversing the polarity of the switch lead wire connection will turn on the indicator light.

● Solid state switch

Connect correctly according to the lead wire color coding in the diagram on the right. Incorrect wiring may cause damage. Please be careful.

● R1

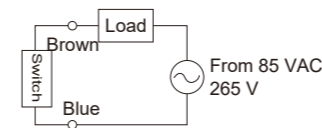

● R2 (Y), M2 (W), T2 (Y), T2J, K2 (Y), F2 (T2YD has no polarity)

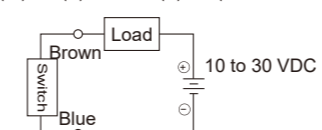

● R3 (Y), M3 (W), T3 (Y), K3 (Y), F3

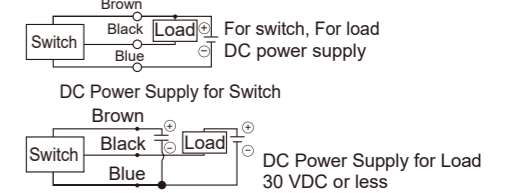

● T3P, K3P, M3P

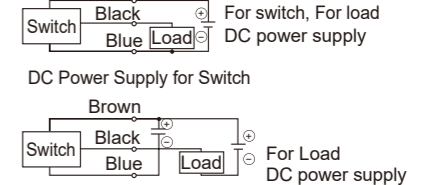

(Connection to Programmable Logic Controller (PLC))

- Connection method varies depending on the type of programmable controller. Connect according to the input specifications.

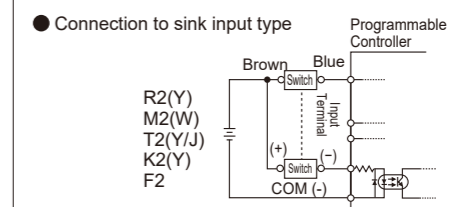
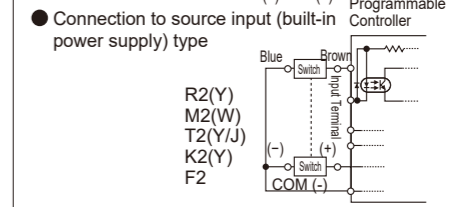
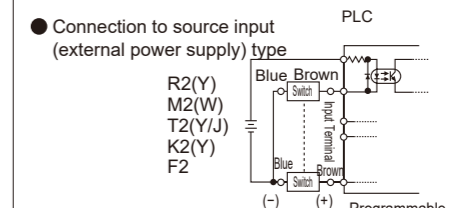
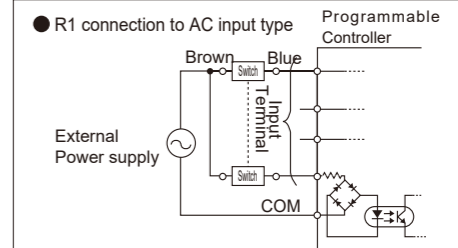

● Connection to source input (external power supply) type

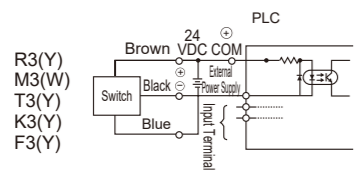

● Connection to source input (built-in power supply) type

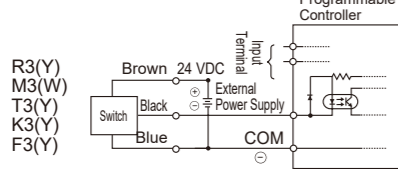

● Example of connection to sink input (external power supply) type

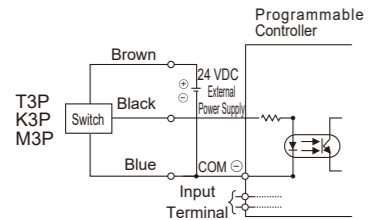

● Example of connection to sink input (built-in power supply) type

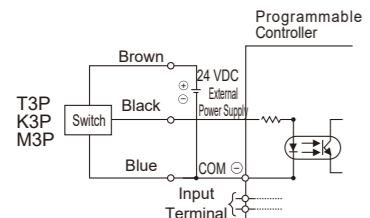

■ Set the switch to the center of its operating range.
Adjust the mounting position of the cylinder switch so that the piston stops at the center of the operating range (the range where it is ON). (The mounting position described in the catalog indicates the optimal position at the stroke end.) If set to the end of the operating range (near the ON/OFF boundary line), operation may become unstable.

■ Install the switch while adhering to the tightening torque.
If tightened beyond the maximum tightening torque, the Set Screw, mounting bracket, switch, etc., may be damaged. Also, if tightened below the minimum tightening torque, the switch mounting position may shift. (For switch mounting method, moving method, tightening torque, etc., please refer to P. 1518 to 1520.)

■ Be careful with terminal box type wiring.

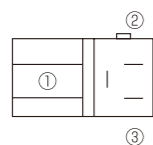

Model	Terminal	①	②	③
R0 (DC), R2, R2Y, R6			+	-
R0 (AC), R1, R4, R5			±	±
R3, R3Y	OUT		+	-

■ Lead wire protection

The minimum bending radius of the lead wire should be 9 mm or more (when fixed). Ensure that repeated bending stress and tensile force are not applied to the lead wire during wiring. For moving parts, please connect and use T2H/VR3 cylinder switch with flex-resistant lead wire specification for higher flexibility (limited to compatible models).

■ Relay

Use the following equivalent relays.

- Omron.....MY type
- Fuji ElectricHH5 type
- Tokyo DenkiMPM type
- PanasonicHC type

1. Notes on "External Force"

⚠ CAUTION

■ Especially for reed switch types, the reed switch (glass tube) may be damaged or its sensitivity may decrease.
Example: T0□ T5□ T8□ type

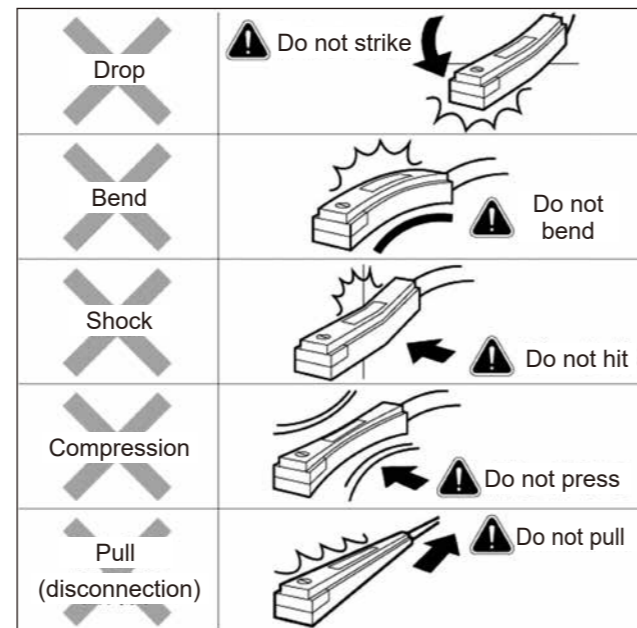

2. Notes on "Overcurrent/Overvoltage"

⚠ CAUTION

- Do not connect directly to the power supply.
- Do not connect to an electromagnetic relay without a protection circuit.

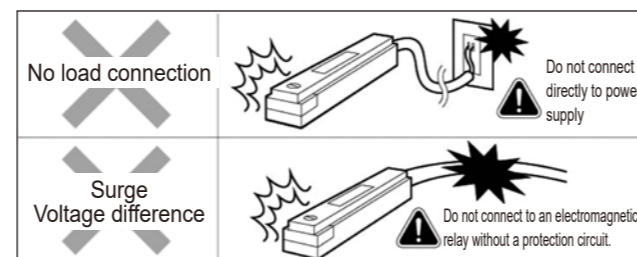

■ For electromagnetic relays and long wiring, install a "protection circuit."

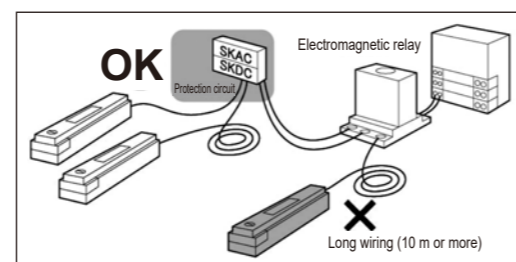

During Use

⚠ Warning

■ Do not flow overcurrent.

If overcurrent flows through the cylinder switch due to a load short circuit, etc., not only will the cylinder switch be damaged, but there is also a risk of fire. If necessary, please provide an overcurrent protection circuit such as a fuse on the output line and power supply line.

⚠ CAUTION

■ Be careful about reverse current due to wire breakage or wiring resistance.

● If other devices, including cylinder switches, are connected to the same power supply as the cylinder switch, shorting the output wire and the - power supply wire, or if the - power supply wire is disconnected, reverse current may flow into the cylinder switch's output circuit, causing damage. This is done to confirm the operation of the control panel's input device.

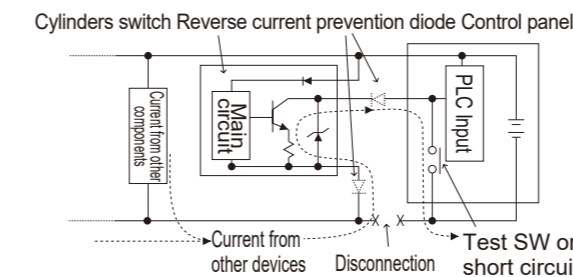

● To prevent damage due to reverse current, take the following measures.

- ① Avoid concentrating current on the power lines, especially the - side power line, and make the wiring as thick as possible.
- ② Limit the equipment connected to the same power supply as the cylinder switch.
- ③ Insert a diode in series with the cylinder switch output line to prevent reverse current flow.
- ④ Connect a diode in series to the negative (-) side of the cylinder switch power line to prevent reverse current.

■ Be careful about surge current bypass.

● If the power supply for inductive loads that generate surges, such as cylinder switches and solenoid valves/relays, is shared, and the circuit is interrupted while the inductive load is operating, surge current may flow into the output circuit and cause damage, depending on the mounting position of the surge absorption element.

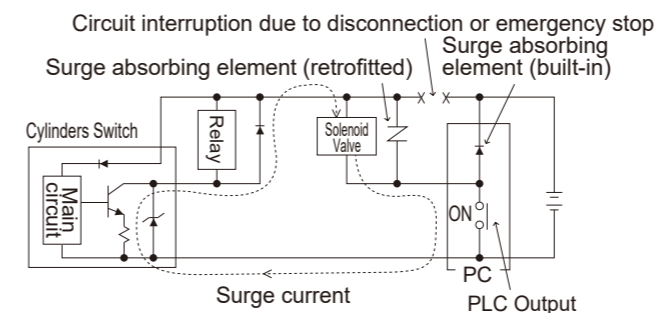

● To prevent damage from surge current bypass, take the following measures.

- ① Separate the power supplies for the output system with inductive loads such as solenoid valves and relays, and the input system such as cylinder switches.
- ② If separate power supplies cannot be used, directly install surge absorbing elements for all inductive loads. Consider surge absorbing elements connected to PLCs, etc., as protecting only that equipment.
- ③ Furthermore, connect surge absorbing elements at various points in the power supply wiring as shown in the diagram below to prepare for disconnection at unspecified locations.

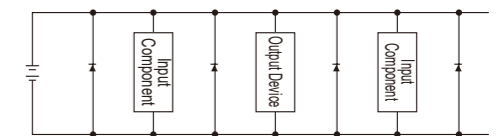

Furthermore, if equipment is connected with connectors, disconnecting the connector while power is on may cause the output circuit to be damaged due to the above phenomenon. Always turn off the power before connecting or disconnecting connectors.

⚠ Caution: Switch Mounting Method

Tie Rod Mount Type

Loosening the Set Screws (2 screws) for fixing the mounting base by 1/2 to 3/4 turn allows axial movement without detachment. For fixing after adjustment, lightly press the holder so that the switch is fixed to the tube, and then tighten the Set Screws. Tightening torque is 1.7 to 2.0 N·m. As a guide, it is sufficient if the hex wrench begins to deflect.

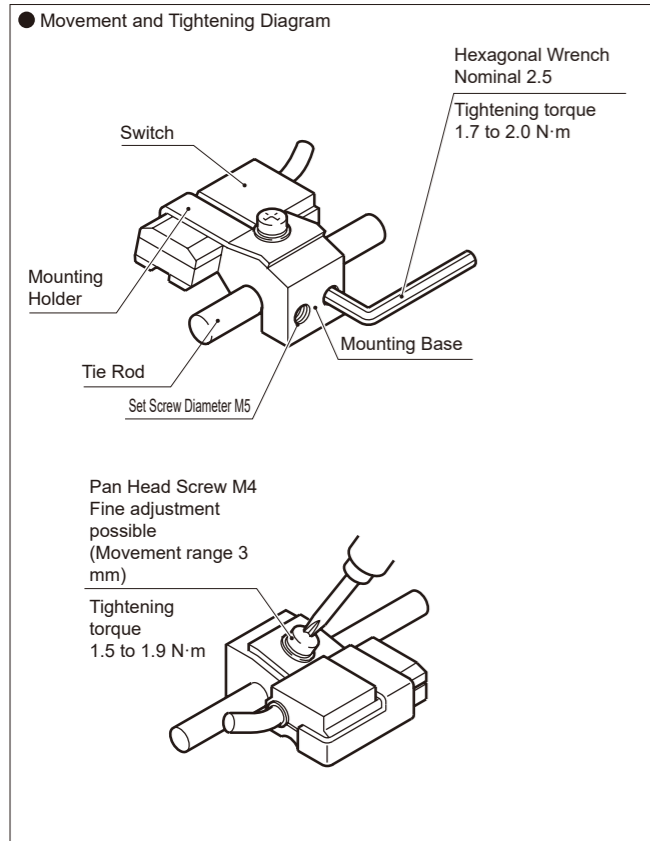

Band Mount Type

Loosen the tightening screw (Pan Head Screw), move the switch body and band along the cylinder tube, and tighten at the specified position. For fine adjustment, fix the band position and move only the switch body. Tightening torque is 0.5 to 0.7 N·m. The tightening torque for HCA $\phi 80$, $\phi 100$ is 1.0 to 1.5 N·m.

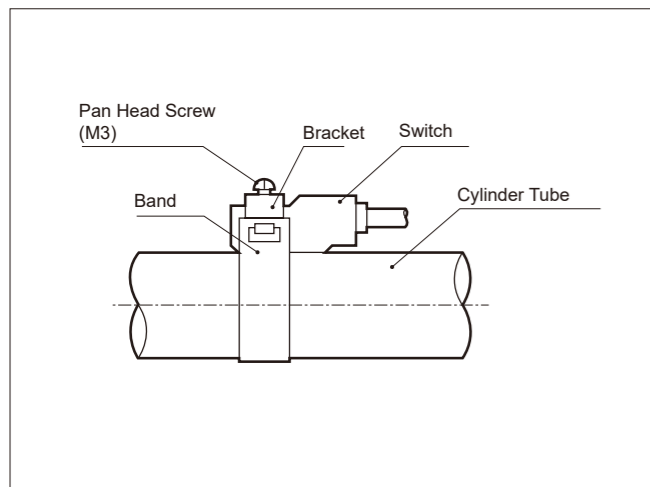

Band Mount Type

- When moving the switch position in the stroke direction
 - The 1-color indicator switch can be finely adjusted by about ± 3 mm from the mounting position at the time of shipment. If the adjustment range exceeds ± 3 mm, or if fine-tuning the position of a 2-color indicator switch, move the band position.
 - The switch rail has a marking 4 mm from the end face of the rail. Use this as a guide for the mounting position when replacing the switch. The marking on the switch rail is set to the switch's highest sensitivity position at the time of factory shipment. If the type of switch changes or if the band is moved, the maximum sensitivity position will change, so adjust the position each time.

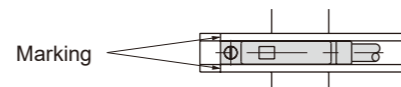

- When moving the switch position in the circumferential direction
 - Loosen the band fixing screw, move the switch rail circumferentially, and tighten it at the specified position. Tightening torque is 0.8 to 1.0 N·m.
- When moving the band position
 - Loosen the band fixing screw, move the switch rail and band along the cylinder tube, and tighten them at the specified position. Tightening torque is 0.8 to 1.0 N·m.

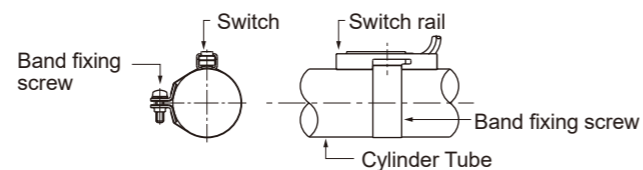

Band Mount Type

Install T-type switches as shown in the diagram below. When using standard T-type switch (SW-T□)

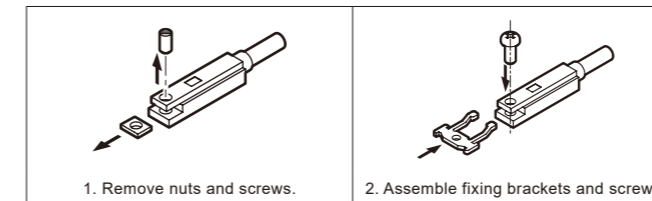

- Insert the square hole of the band into the fixing bracket and attach it to the cylinder.

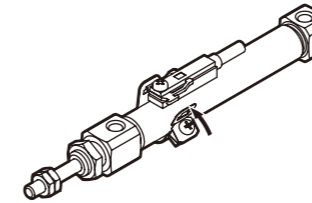

- If it is difficult to install, follow the steps below.
 - Loosen the screw on the switch side.
 - Insert the square hole of the band into the fixing bracket.

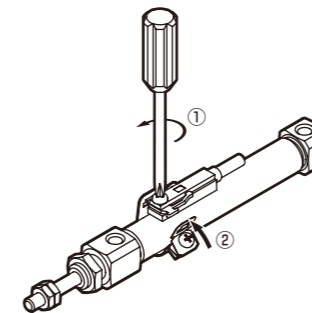

- Tighten the screw on the switch side. Tightening torque: 0.1 to 0.15 N·m

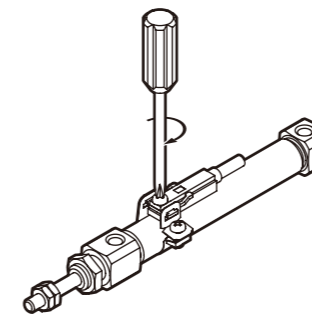

- Tighten the screw on the band side. Tightening torque: 0.1 to 0.15 N·m

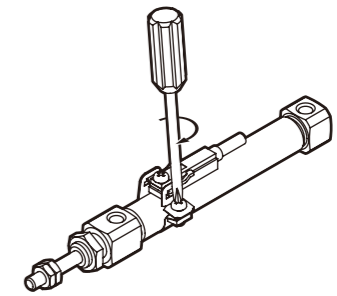

- For switch mounting position adjustment
Loosen the screw on the switch side, adjust the position, and tighten the screw to fix it at the optimal position. Tightening torque: 0.1 to 0.15 N·m

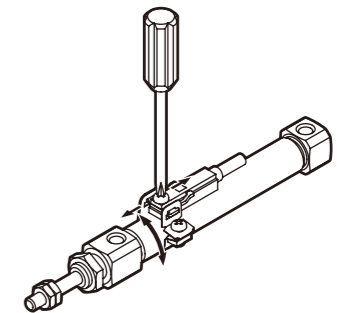

Switch Groove Mount Type

Loosen the tightening screw (Set Screw), move the switch body along the switch groove, and tighten at the specified position. For T2, T2W, T3, T3W, T0, T5, K2, K3, K0, K5, use a flat-blade screwdriver (watchmaker's screwdriver, precision screwdriver, etc.) with a grip diameter of 5 to 6 mm, tip width of 2.4 mm or less, and thickness of 0.3 mm or less to tighten the switch fixing screw with a tightening torque of 0.1 to 0.2 N·m. For T□C, T2J, T2Y, T3Y, K2Y, K3Y, T2YD, T1, T8, T2YL, T3YL, ET0, tighten with a torque of 0.5 to 0.7 N·m. For F2□, F3□, F2Y□, F3Y□, tighten with a torque of 0.03 to 0.08 N·m.

T2YD Tie Rod Mount Type

① Fine adjustment

Loosen the slotted hex bolt (A), move only the switch body, and tighten it at the specified position. Tightening torque is 0.5 to 0.7 N·m.

② Coarse adjustment

Loosen all slotted bolts (A) and Set Screws, move the entire mounting bracket to the specified position, and then tighten the slotted bolt (A). Tightening torque is 0.5 to 0.7 N·m. Then tighten the Set Screws. Tightening torque is 1.7 to 2.0 N·m.

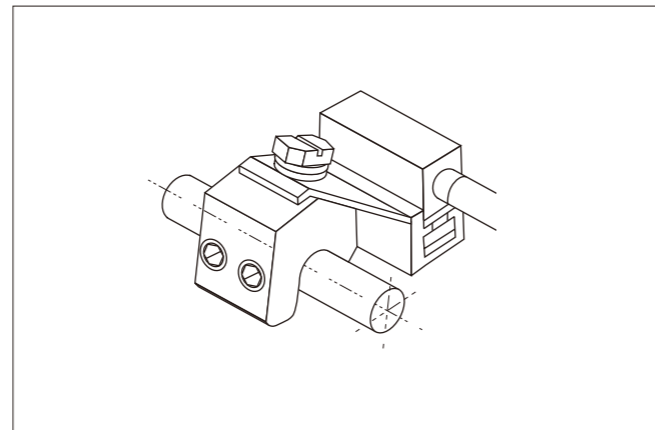
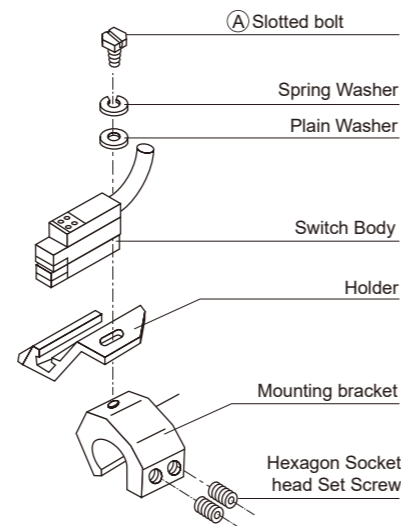

⚠ Caution

Contact protection circuit (SKAC, SKDC)

If you are using a reed switch and the circuit configuration with the load falls under the following, the contact life may be reduced (may remain ON). Connect a contact protection circuit within 2 m of the switch.

- When the operating load is an inductive load (relays, valves, etc. (coil-driven loads)) or a capacitive load (programmable controllers, etc. (loads containing capacitors))
- When the lead wire wiring length is as follows
 - 12 VDC : 100 m or more
 - 24 VDC : 50 m or more
 - 100 VAC : 20 m or more
 - 200 VAC : 10 m or more
- When there are other factors that cause overvoltage or overcurrent

For details on the contact protection circuit, refer to P. 1487.

Mounting method to R□B terminal box

Connection to the R□B terminal box should be done according to the following procedure, referring to the diagram below.

- ① After completely removing the fixing screws, pull the terminal box out from the switch.
- ② From the top of the case, push out the pin support to separate the case and pin support.
- ③ Remove the cap, and take out the washer and gasket.
- ④ Determine the lead wire exit direction of the terminal box.
- ⑤ Referring to the top view of the case mounting direction, cut the lead wire to match the exit direction, and strip the seal/sheath.
- ⑥ Crimp the included terminal.
- ⑦ Pass the lead wire through the cap, washer, gasket, and case in that order, paying attention to the orientation. Pass the lead wire through the case and pull it out with needle-nose pliers.
- ⑧ While inserting the terminal into the pin support, push it into the case, paying attention to the orientation. Push until the upper end rib of the pin support comes out to the top surface of the case.
- ⑨ Insert the fixing screws into the case/pin support.
- ⑩ Insert the gasket and washer into the case and tighten with the cap.
- ⑪ Insert the case into the switch terminal and fix it with the fixing screws.

● Lead wire cutting length

The lead wire cutting length varies depending on the case mounting direction. Refer to the table below. For 3-wire type, please consult us.

Case mounting direction	Top view	Bottom view	Lead wire length
Case mounting direction Top view			
Case mounting direction Bottom view			
Lead Wire Length			

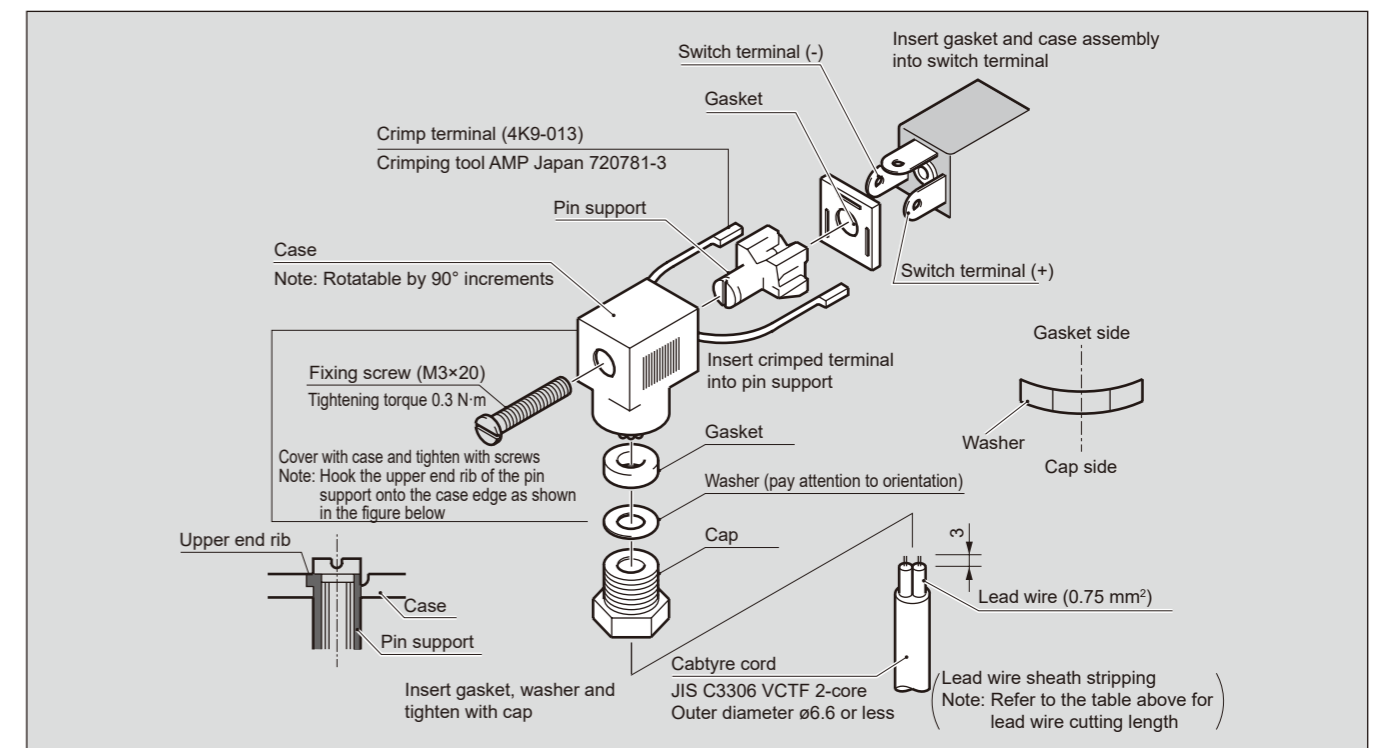

Mounting method to E0 terminal box

For wiring to the terminal box, prepare heat-resistant cabtyre cord and flex conduit, and refer to the diagram below. Note that MAS insert, MAS holder, and cap nut are included as accessories.

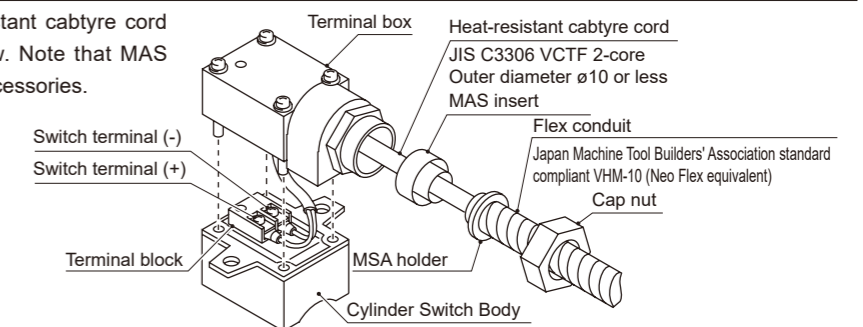

For precautions during mounting, installation, adjustment, use, and maintenance, refer to "During Use" in this catalog and the CKD Components Product website (<https://www.ckd.co.jp/kiki/en/>) -> "Model No." -> "Instruction Manual".