



Safety Precautions

Be sure to read this section before use.

When designing and manufacturing equipment using CKD products, the manufacturer is obligated to ensure that the safety of the mechanism, pneumatic control circuit and/or water control circuit and the system that runs the electrical controls are secured. It is important to select, use, handle and maintain CKD products appropriately to ensure their safe usage. Observe warnings and precautions to ensure device safety. Check that device safety is ensured, and manufacture a safe device.

WARNING

1 This product is designed and manufactured as a general industrial machine part. It must be handled by an operator having sufficient knowledge and experience.

2 Use this product in accordance with specifications.

This product must be used within its stated specifications. In addition, never modify or additionally machine this product. This product is intended for use in general industrial machinery equipment or parts. It is not intended for use outdoors (except for products with outdoor specifications) or for use under the following conditions or environments. (Note that this product can be used when CKD is consulted prior to its usage and the customer consents to CKD product specifications. The customer should provide safety measures to avoid danger in the event of problems.)

- ① Use for applications requiring safety, including nuclear energy, railways, aircraft, marine vessels, vehicles, medical devices, devices or applications in contact with beverages or foodstuffs, amusement devices, emergency cutoff circuits, press machines, brake circuits, or safety devices or applications.
- ② Use for applications where life or assets could be significantly affected, and special safety measures are required.

3 Observe organization standards and regulations, etc., related to the safety of the device design and control, etc. ISO4414, JIS B 8370 (Pneumatic fluid power - General rules and safety requirements for systems and their components) JFPS2008 (Principles for pneumatic cylinder selection and use) Including the High Pressure Gas Safety Act, Industrial Safety and Health Act, other safety rules, organization standards and regulations, etc.

4 Do not handle, pipe, or remove devices before confirming safety.

- ① Inspect and service the machine and devices after confirming safety of the entire system related to this product.
- ② Note that there may be hot or charged sections even after operation is stopped.
- ③ When inspecting or servicing the device, turn OFF the energy source (air supply or water supply), and turn OFF power to the facility. Discharge any compressed air from the system, and pay enough attention to possible water leakage and leakage of electricity.
- ④ When starting or restarting a machine or device that incorporates pneumatic components, make sure to secure system safety, such as pop-out prevention measures.

5 Observe the warnings and cautions on the following pages to prevent accidents.

■ Precautions are ranked as "DANGER", "WARNING", and "CAUTION" in this section.

- DANGER:** In the case where the product operation is mishandled and/or when the urgency of a dangerous situation is high, it may lead to fatalities or serious injuries.
- WARNING:** A dangerous situation may occur if handling is mistaken, leading to fatal or serious injuries.
- CAUTION:** A dangerous situation may occur if handling is mistaken, leading to minor injuries or property damage.

Note that some items indicated with "CAUTION" may lead to serious results depending on the conditions. All items contain important information and must be observed.

Warranty

1 Warranty period

The product specified herein is warranted for one (1) year from the date of delivery to the location specified by the customer.

2 Warranty coverage

If the product specified herein fails for reasons attributable to CKD within the warranty period specified above, CKD will promptly provide a replacement for the faulty product or a part thereof or repair the faulty product at one of CKD's facilities free of charge. However, following failures are excluded from this warranty:

- 1) Failure caused by handling or use of the product under conditions and in environments not conforming to those stated in the catalog, the Specifications, or the Instruction Manual.
- 2) Failure caused by use of the product exceeding its durability (cycles, distance, time, etc.) or caused by consumable parts.
- 3) Failure not caused by the product.
- 4) Failure caused by use not intended for the product.
- 5) Failure caused by modifications/alterations or repairs not carried out by CKD.
- 6) Failure caused by reasons unforeseen at the level of technology available at the time of delivery.
- 7) Failure caused by acts of nature and disasters beyond control of CKD.

The warranty stated herein covers only the delivered product itself. Any loss or damage induced by failure of the delivered product is excluded from this warranty.

Note: For details on the durability and consumable parts, contact your nearest CKD sales office.

3 Compatibility check

The customer is responsible for confirming the compatibility of CKD products with the customer's systems, machines and equipment.

Precautions for export

1 Security Trade Control

The products in this catalog and their related technologies may require approval before export or provision. For the sake of maintaining world peace and safety, there may be cases in which approval under the Foreign Exchange and Foreign Trade Control Law is required in advance, depending on the country to where the product or related technology is being exported or provided. The scope of products and related technologies requiring approval are listed in the Export Trade Control Order Appendix Table 1 or Foreign Exchange Order Appendix Table. The Export Trade Control Order Appendix Table 1 and Foreign Exchange Order Appendix Table contain the following two types of information.

- "List controls" specified for items 1 to 15
- "Catch-all controls" that do not indicate specifications by item, but restriction by application (Section 16)

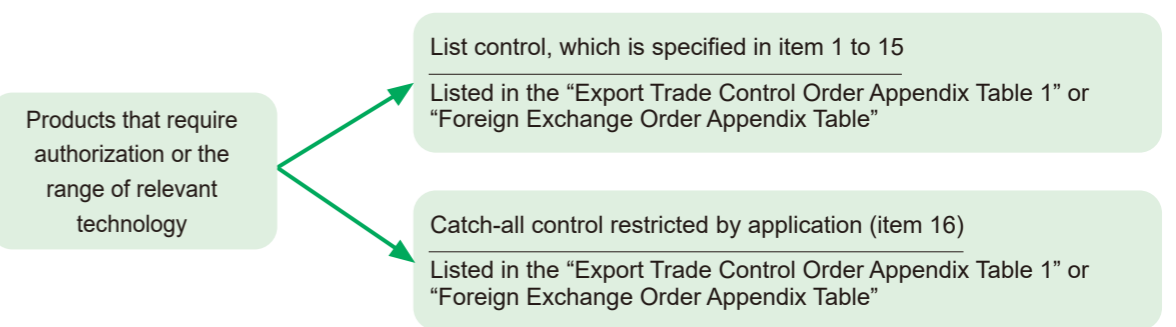

An application for approval is received by the Security Export Licensing Division of the Ministry of Economy, Trade and Industry or local bureaus of the Ministry of Economy, Trade and Industry.

2 Products and related technologies in this catalog

The products and related technologies in this catalog are subject to the catch-all control of the Foreign Exchange and Foreign Trade Control Law. When exporting or providing the products or related technologies in this catalog, ensure that they are not used for arms or weapons.

3 Contact

Contact your local CKD Sales Office for information on the Security Trade Control of products and related technologies in this catalog.

*For cylinder switches, please check P. 1512.

Design / Selection

1. Confirmation of Specifications

Warning

- Use within the product's specified operating range.
The products described in this catalog are designed to be used only in compressed air systems. Do not use outside the specified pressure or temperature range as it may cause damage or malfunction. (See specifications). If using fluids other than compressed air and low hydraulic pressure, please consult us.

- If product dimensional accuracy is required, please consult us separately.

The dimensional tolerance of pneumatic cylinders is set based on JIS B8368. If accuracy is required, please inquire in advance.

2. Design for Safety

Warning

- If the force changes due to twisting of the sliding parts of the machine, there is a danger that the cylinder's Piston rod may extend suddenly.

In such cases, there is a risk of injury to the human body, such as getting hands or feet caught, and damage to the machine, so make adjustments so that the machine moves smoothly and design it so that it does not cause injury to the human body.

- If there is a risk of danger to the human body, install a protective cover.

If the drive part of the cylinder poses a risk of danger to personnel, install a protective cover. Design the structure so that personnel cannot enter the cylinder's operating range or directly touch that area.

- Consider the possibility of circuit pressure drop due to power outages, etc.

When using a cylinder for a clamping mechanism, if the circuit pressure drops due to a power outage, etc., the clamping force will decrease and there is a risk that the workpiece may come off. Therefore, incorporate a safety device to prevent injury or damage to personnel or machinery. Lifting devices and lifts also require consideration for fall prevention.

- Consider the possibility of power source failure.

For equipment controlled by power sources such as pneumatic, hydraulic, or electric, take measures to prevent injury or damage to personnel or equipment even if these power sources fail.

- Design a circuit to prevent sudden projection.

When driving a cylinder with an exhaust center type directional control valve, or when starting after exhausting the residual pressure of the circuit, if pressure is applied to one side of the piston from a state where the air in the cylinder is exhausted, the driven object pops out at high speed. In such cases, there is a risk of causing injury to the human body such as pinching hands or feet, or causing damage to the machine, so please design a pop-out prevention circuit.

- Consider the operating state during an emergency stop.
Design so that injury to the human body and damage to equipment/devices due to cylinder operation do not occur when the safety device operates and the machine stops during system abnormalities such as emergency stop or power failure.

- Consider the operating state when restarting after an emergency stop or abnormal stop.

Design the system so that restarting does not cause harm to personnel or damage to equipment. Also, if it is necessary to reset the cylinder to the starting position, design a safe control device.

- Take necessary measures in advance to prevent adverse effects on people or things if this product malfunctions.

CAUTION

- Use within a range where the piston does not collide and break at the stroke end.

When a piston with inertial force collides with the cover at the stroke end and stops, use within the allowable absorption energy range.

- Install a speed controller on the cylinder.

Use within the operating piston speed range of each cylinder.

- Install a "pressure switch" and "residual pressure exhaust valve" on the compressed air supply side of the equipment.

- The pressure switch prevents operation if the set pressure is not reached. The residual pressure exhaust valve discharges the compressed air remaining in the pneumatic circuit and prevents accidents due to the operation of pneumatic equipment due to residual pressure.

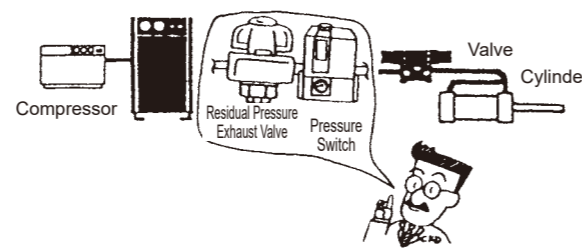

- The load factor for fall prevention cylinders should be 50% or less.

3. Application Specific Design

Warning

- When a deceleration circuit or shock absorber is necessary.

If the speed of the driven object is high or its mass is large, it will be difficult to absorb the impact with only the cylinder's cushion. Therefore, provide a circuit to decelerate before entering the cushion, or use an external shock absorber to mitigate the impact. In this case, sufficiently consider the rigidity of the machinery.

- When inertia, vibration, etc. occur

When mounting the cylinder on a moving object (X-axis module, pallet, etc.), design considering the inertia, vibration, etc. generated when the moving object stops.

- About Intermediate Stop

When performing an intermediate stop of the cylinder piston with a 3-position closed center type directional control valve, accurate and precise positioning like low hydraulic pressure is difficult due to the compressibility of air. Also, since valves and cylinders do not guarantee zero air leakage, it may not be possible to hold the stop position for a long time. If long-term stop position holding is required, please consult us.

4. Operating Environment

Warning

- Install the product avoiding rain, water, direct sunlight, and high humidity.

- Do not use the product in an atmosphere where there is a risk of corrosion.

Use in such environments can cause damage and malfunction. Also, even for plated materials used for Piston Rods, tie rods, etc. in cylinders, plating is not applied to machined parts (thread width, cut surface). Rust can occur even in a general environment, so take necessary measures.

- In dusty places or places exposed to water droplets, oil droplets, cutting oil, or coolant, install a cover, etc.

If there is a lot of dust, please use the type with a powerful scraper. If liquid splashes, please use the coolant resistant type.

- If the Ambient Temperature is 5°C or less, moisture in the circuit may freeze, causing malfunctions such as operational defects. Therefore, remove moisture and prevent freezing.

CAUTION

- When using a cylinder with a valve with AC voltage, humming noise may occur depending on the operating conditions. If humming noise is a problem depending on the operating environment, select DC voltage.

- Some models use oil-impregnated bearings, and oil may be discharged to the outside of the cylinder. Be careful when using in locations where oil discharge is undesirable.

5. Durability

Warning

- Durability varies depending on usage conditions and model characteristics.

CAUTION

- Bellows are consumable parts.
Replace as necessary.

6. Pneumatic Source

Warning

- Use clean, dry compressed air.
Do not use compressed air containing chemicals, synthetic oil containing organic solvents, salt, corrosive gas, etc. as it may cause damage or malfunction.

CAUTION

- Use dry compressed air that does not generate drain in the piping.

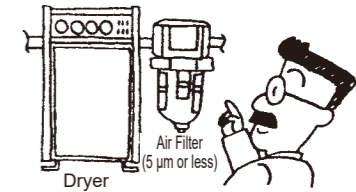

- Drain occurs if there is a temperature drop inside pneumatic piping or pneumatic equipment.
- If the piping volume is larger than the cylinder volume (atmospheric pressure equivalent volume), condensed water droplets will accumulate as drain without the compressed air in the cylinder being completely discharged at each switching of the solenoid valve.
- Drain enters the air passages inside pneumatic equipment, momentarily blocking the passages and causing malfunction.
- Rust generated by drain will cause pneumatic equipment failure.
- Drain washes away lubricating oil, causing poor lubrication.

- Use of ultra-dry air is unsuitable for standard pneumatic equipment. Use equipment compatible with ultra-dry air.

- Ultra-dry compressed air shortens the life of pneumatic components.
- Use a solenoid valve for DC voltage drive.

- Use compressed air free from oxidized oil, tar, carbon, etc., from the air compressor.

- Oxidized oil, tar, carbon, etc., entering and adhering inside pneumatic equipment increases the resistance of sliding parts, causing malfunction.
- Lubricating oil mixed with oxidized oil, tar, carbon, etc., will wear down the sliding parts of pneumatic equipment.

- Use compressed air that does not contain solid foreign matter.

- Solid contaminants in the compressed air can enter pneumatic equipment, causing wear on sliding parts or sticking phenomena; 5 μm or less.
- Perform regular maintenance inspections of the compressor.

7. Usage Method

CAUTION

- It is initially lubricated, so it can be used without lubrication. If lubricating, use Turbine Oil Class 1 (additive-free) ISO-VG32. Also, if lubrication is stopped midway, malfunction will occur due to the loss of the initial lubricant, so be sure to continue lubrication. It is necessary to decide whether to adopt a non-lubricated or lubricated specification for pneumatic equipment and ensure that the chosen method is reliably managed.

- Provide intermediate support for long-stroke cylinders.
For long stroke cylinders, provide intermediate support to prevent rod sag, tube deflection, and rod damage due to vibration or external load.

- Use within the Max stroke of the mounting style.

Refer to Intro 30.

- Cylinders with air cushion experience a speed change at the beginning of movement.

For cylinders with air cushion, speed changes occur when the cushion ring comes off the cushion packing at the beginning of movement. Depending on conditions such as speed controller placement and adjustment, piping diameter, air pressure, and cushion needle opening, the change may become large. If it is necessary to prevent this, please consult us.

- Avoid using multiple cylinders in synchronization as much as possible.

Synchronization cannot be achieved, causing twisting of the Piston Rod and leading to malfunction. If synchronous operation is necessary, be sure to provide a separate guide device with rigidity.

- When installing clevises and trunnions, confirm that they can rotate freely without interference during the full stroke operation of the cylinder before use.

- If the direction of load movement changes with operation, use a swinging type cylinder (clevis type, trunnion type) where the cylinder itself can rotate by a certain angle. Also, install the connecting fitting at the Rod End so that it moves in the same direction as the Cylinder Body's movement.

- Do not connect a fixed type cylinder to an arm that performs circular motion. In this case, connect it to an oscillating type cylinder.

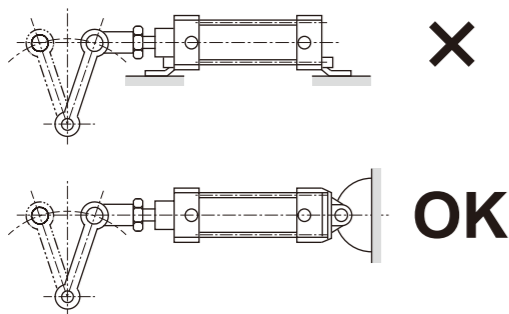

- To prevent breakage of the Piston Rod End screw, wear of the bushing, seizure, etc., connect the Piston Rod End and the load with a free joint or simple flow controller, etc., so that there is no twisting at any position of the stroke.

- If the clearance between the clevis or trunnion and the mating bearing is large, a bending action will occur on the pin or shaft. Therefore, do not make this gap too large. (Recommended fit H10/e8)

- In the figure below, if the height H from the mounting surface of the bearing bracket to the bearing position is large, a large force will be generated on the mounting part of the bracket by the cylinder force, which may cause damage to bolts, etc.

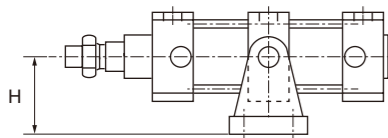

- Cylinders may have slight oil seepage from sliding parts, packings, and gaskets. Be careful when using in locations where oil seepage is undesirable.

- Precautions for Using Relief Port

Exhaust treatment type (P72) cannot be used with vacuum scavenging. And vice versa. This will cause particle scattering or defects, so absolutely do not do it.

8. Securing Space

CAUTION

- Ensure space around the cylinder for mounting, removal, wiring, and piping work.

9. Specification in Instruction Manual

CAUTION

- Clearly state the maintenance conditions in the equipment's instruction manual.

- Product functionality may significantly decrease, and safety may not be ensured depending on usage status, operating environment, and maintenance. Proper maintenance allows the product to fully demonstrate its functions.

Installation / Mounting / Adjustment

1. Mounting

Warning

- When mounting the cylinder, protect the load from falling or tipping over.

Caution

- Do not remove the cylinder packaging bag or the dust-proof port seal for the piping port until just before performing piping.

- If the dust-proof port seal for the piping port is removed before piping connection work, foreign matter may enter the cylinder from the piping port, causing failure, malfunction, etc.

- If the cylinder weight is 15 kg or more, use lifting equipment.

- Do not hit or grip objects with the cylinder tube and Piston Rod sliding parts, causing scratches or dents. The bore is manufactured with precise tolerances, so even slight deformation can cause a malfunction. Scratches or dents on the Piston Rod sliding part will damage packings and cause air leakage.

- If the direction of load movement is not parallel to the Piston Rod axis, twisting may occur in the Piston Rod and main body (tube), posing a risk of the Piston Rod flying out. Twisting also causes seizure, breakage, etc. Be sure to align the Piston Rod axis with the direction of load movement.

- Prevent seizure of rotating parts.

- Apply grease to rotating parts (pins, etc.) to prevent seizure.

2. Pneumatic Source

CAUTION

- Install a pneumatic filter immediately before the circuit using the pneumatic equipment.

- Install an air dryer and filter to remove moisture in the piping. Also, install a filter near the directional control valve (primary side) to remove rust, foreign matter, and drain.

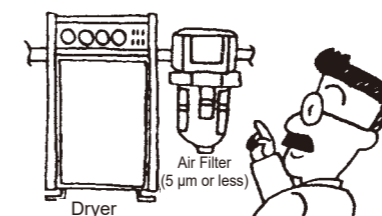

- When supplying compressed air after completing pipe connections, supply it so that high pressure is not applied suddenly.

- Piping connections may come off, and piping tubes may spring out, causing accidents.

- If compressed air is supplied too slowly, sealing pressure may not be generated depending on the solenoid valve's internal seal mechanism, potentially causing air leakage.
- The cylinder may operate suddenly.

3. Piping

CAUTION

- When piping, refer to the instruction manual and ensure connection ports, etc., are not mistaken.

- This will cause a malfunction.

- When connecting piping, wrap sealing tape clockwise from a position 2 threads or more inward from the tip of the pipe thread.

- If sealant tape protrudes beyond the threaded part of the piping, it will be cut by screwing in, and the cut piece will enter the interior, causing failure.



- Ensure that piping connected to the cylinder does not detach due to vibration, loosening, or pulling phenomena.

- If the exhaust side piping of the pneumatic circuit detaches, cylinder speed control will become impossible.
- In the case of a chuck holding mechanism, the chuck will release, creating a dangerous situation.

- When using nylon tubes or urethane tubes, pay attention to the following.

- In atmospheres where spatter scatters, use flame-resistant tubes or metal pipes.

- Use corrosion-resistant piping materials such as galvanized pipes, Stainless Steel pipes, nylon tubes, rubber hoses, etc.

■ Tighten with the appropriate torque during piping connection.

- The purpose is to prevent air leaks and screw damage.
- To avoid damaging the threads, first tighten by hand, then use a tool.



[Reference Value] Please refer to the instruction manual.

Connection Thread	Tightening Torque (N·m)
M3	0.3 to 0.6
M5	1 to 1.5
Rc 1/8	3 to 5
Rc 1/4	6 to 8
Rc 3/8	13 to 15
Rc 1/2	16 to 18
Rc 3/4	19 to 40
Rc 1	41 to 70

■ When piping, be sure to perform flushing immediately before connecting to pneumatic equipment.

- It is necessary that foreign matter that entered during piping does not enter the pneumatic components.

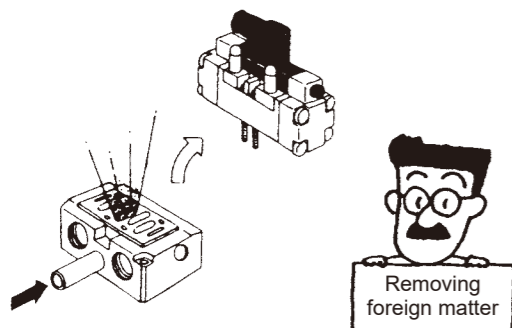

4. Confirmation Before Operation

Warning

- Before operating, confirm that there is no looseness or abnormality in the load or cylinder mounting fasteners.
- Do not use until it is confirmed that the equipment operates properly.
After installation, repair, or modification, connect compressed air or electricity, perform appropriate functional tests and leak tests, and confirm that installation is normal.
- Confirm that there is no mechanical interference or abnormality in the operating system.
- Gradually increase and set the pressure while confirming that there is no abnormality in the operation of the equipment.
- Starting with the exhaust side at atmospheric pressure is dangerous as the rod may extend suddenly. When starting, always apply pressure to the exhaust side cylinder chamber.

CAUTION

- When piping connection is complete and compressed air is supplied, be sure to confirm that there are no air leaks in all parts of the piping connection.
 - Apply leak detection fluid with a brush to the piping connection parts to confirm there are no air leaks.

■ Be sure to read the instruction manual.
Read carefully and understand the contents before using the product. Also, keep it so that you can check it at any time.

5. Adjustment

Warning

■ When adjusting speed with a speed controller, adjust by gradually opening the needle from the closed state. Starting speed adjustment in the open state is dangerous as the rod may extend suddenly.

■ The effect of the cushion with air cushion is adjusted at the time of shipment. However, re-adjust the cushion needle for use in accordance with the size of the load and piston speed.

Gradually open the needle from the closed state to adjust the cushioning effect. Note that if the cushion needle is loosened too much, there will be no cushioning effect, and it may fall off. After adjustment, tighten and fix the needle nut (Hexagon Nut). Use within the allowable kinetic energy value. If used exceeding the allowable value, the product may be damaged.

■ When the cylinder is in operation, do not enter or put your hand in its operating range.

Use / Maintenance

1. Maintenance and Inspection

Warning

■ Perform maintenance inspections carefully according to the instruction manual.
 Mishandling will cause damage or malfunction of equipment or devices.

CAUTION

■ Implement daily and periodic inspections systematically so that maintenance management is performed correctly.

- Insufficient maintenance management will significantly impair product functionality, leading to reduced lifespan, damage, malfunction, and other defects or accidents.

- 1) Pressure management of supply compressed air
 - Is the set pressure being supplied?
Does the pressure gauge indication during equipment operation show the set pressure?

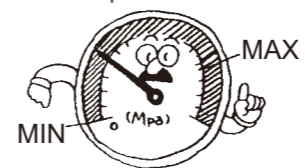

- 2) Management of pneumatic filter
 - Is drain being discharged normally?
Is the contamination status of the bowl and element normal?
- 3) Compressed air leakage management at piping connection parts
 - Is the condition of the connection parts of moving parts, in particular, normal?
- 4) Solenoid Valve Operating Status Management
 - Is there any delay in operation, and is the exhaust state normal?
- 5) Pneumatic Actuator Operating Status Management
 - Is operation smooth?
Is the end-of-stroke stop status normal?
Is the connection with the load normal?
- 6) Management of lubricator
 - Is oil level adjustment normal?
- 7) Lubricating Oil Management
 - Is the supplied lubricating oil the correct type?

■ If air leakage increases or equipment does not operate normally, do not use.

- After repair or modification, connect compressed air or electricity, perform appropriate functional inspections and leak tests, and confirm normal operation.

■ After a long period of disuse, confirm normal operation when restarting.

■ Replace consumable parts that have exceeded their rated life with new ones during periodic inspections.
Do not use consumable parts that have been stored for 5 years or more.

■ Store consumable parts in a cool, dark place away from direct sunlight.

■ If lubrication of sliding surfaces deteriorates or they become dry, periodically apply lithium grease (general type) or fluorine grease (heat-resistant, low-speed, low-friction, P7 type, etc.). Also, be sure to remove foreign matter from the sliding surface before applying grease. If the type of grease used is unknown, please contact us.

2. Influence of Fluorine Grease

Warning

■ If you smoke cigarettes, etc., with hands that have fluorine grease from cylinders using fluorine grease (heat-resistant, low-speed, low-friction, P7, etc.), harmful gases will be generated, which may harm the human body, so please be careful.

3. Removal

Warning

■ Removal of Equipment and Supply/Exhaust of Compressed Air

When removing equipment, confirm that measures to prevent the driven object from falling or running away have been taken, then shut off the supply air and connected power, and exhaust the compressed air in the system before proceeding. When restarting, confirm that projection prevention measures have been taken, then proceed with caution.



■ When removing the load from a double-rod cylinder, be sure to do so with the Piston Rod width across flats on the load side fixed. Note that if you perform it without fixing the Piston Rod on the load side, the fastening part (screwed part) of the Piston Rod may loosen.

■ Perform cylinder removal work after taking measures to prevent the load from falling or tipping over.

4. Disassembly / Assembly

Warning

■ Disassemble the cylinder after removing it from the equipment.

■ When performing disassembly and assembly, ensure it is done by a worker who has acquired specialized knowledge.

After disassembly and reassembly, perform leak and operation tests before reassembling onto the equipment.

- When disassembling a single-acting cylinder, be very careful as parts may be ejected due to the spring.
- Install and remove the rod metal using appropriate pliers (C-type Retaining Ring installation tool).
- Even when using appropriate pliers (C-type Retaining Ring installation tool), the Retaining Ring may detach from the tip of the pliers, fly off, and cause damage to personnel and surrounding equipment, so be careful. Also, when installing, confirm that it is securely in the Retaining Ring groove before supplying air.

⚠ CAUTION

- When performing maintenance such as replacing consumable parts, disassemble and reassemble on a test bench, etc., in a clean atmosphere free of dust, and perform a functional inspection to ensure the equipment operates normally.