

Power Arm PAW Series

INSTRUCTION MANUAL

SM-A13989-A/6

ORIGINAL INSTRUCTIONS



- Read this Instruction Manual before using the product.
- Read the safety notes carefully.
- Keep this Instruction Manual in a safe and convenient place for future reference.
- SM-A13989-A/5~ is applied from serial No.230928 (from Sep.28.2023).

PREFACE

Thank you for purchasing CKD's Power Arm PAW Series.

The Power Arm is an assist device for general industry using a pneumatic cylinder as part of its body to realize a compact and light-weight design and having improved bending and torsional stiffness. In addition, it can be folded for compact storage.

This Instruction Manual contains basic matters such as installation and usage instructions in order to ensure optimal performance of the product. Please read this Instruction Manual thoroughly and use the product properly.

Keep this Instruction Manual in a safe place and be careful not to lose it.

This Instruction Manual is intended for Power Arm PAW Series. The specifications for any special model may differ from those stated in this Instruction Manual. Check the specifications on the specification drawing of each product.

Product specifications and appearances presented in this Instruction Manual are subject to change without notice.

- The product is intended for users who have basic knowledge about materials, piping, electricity, and mechanisms of pneumatic components. CKD shall not be responsible for accidents caused by persons who selected or used the product without knowledge or sufficient training.
- Since there are a wide variety of customer applications, it is impossible for CKD to be aware of all of them. Depending on the application or usage, the product may not be able to exercise its full performance or an accident may occur due to fluid, piping, or other conditions. It is the responsibility of the customer to check the product specifications and decide how the product shall be used in accordance with the application and usage.

Contact

CKD Corporation
2-250, Oji, Komaki-shi, Aichi, JAPAN 485-8551
Phone +81-568-77-1111 Fax +81-568-77-1123

CKD Europe B.V.
Beechavenue 125A, 1119 RB Schiphol-Rijk, The Netherlands
Phone: +31 23 554 1490 Mail: info@ckdeu.com

SAFETY INFORMATION

When designing and manufacturing any device incorporating the product, the manufacturer has an obligation to ensure that the device is safe. To that end, make sure that the safety of the machine mechanism of the device, the fluid control circuit, and the electric system that controls such mechanism is ensured.

To ensure the safety of device design and control, observe organization standards, relevant laws and regulations, which include the following:



In order to use our products safely, it is important to select, use, handle, and maintain the products properly.

Observe the warnings and precautions described in this Instruction Manual to ensure device safety.

Although various safety measures have been adopted in the product, customer's improper handling may lead to an accident. To avoid this:



Thoroughly read and understand this Instruction Manual before using the product.

To explicitly indicate the severity and likelihood of a potential harm or damage, precautions are classified into three categories: "DANGER", "WARNING", and "CAUTION".



 DANGER	Indicates an imminent hazard. Improper handling will cause death or serious injury to people.
 WARNING	Indicates a potential hazard. Improper handling may cause death or serious injury to people.
 CAUTION	Indicates a potential hazard. Improper handling may cause injury to people or damage to property.

Precautions classified as "CAUTION" may still lead to serious results depending on the situation. All precautions are equally important and must be observed.

Other general precautions and tips on using the product are indicated by the following icon.

	Indicates prohibited actions that must not be performed in any case.
	Indicates mandatory actions that must be performed.
	Indicates general precautions and tips on using the product.

The following symbols are added to facilitate understanding of warning messages.

	Indicates that there are mechanical hazards such as fractures and injuries caused by pinching if your fingers or hands are inserted into any gaps on the product or equipment.
	Indicates that there are electrical hazards such as electric shock, death, burn and fire.

Definition of Workers who Handles the Product

This Instruction Manual is intended for all workers who handle this product. However, the workers are classified depending on their ability and experience in operation to ensure the safety.

CKD defines the following three categories of workers and only the relevant workers are allowed to perform the described operation.

▪ Operator

This person is allowed to operate the product. The operator is required to acquire sufficient knowledge and operating skills to use this product. The operator shall carefully read this Instruction Manual and sufficiently understand the operation procedures and safety precautions before operating this product.

▪ Maintenance person

In addition to the work permitted to the operator, this person is allowed to perform periodic maintenance work such as periodic inspection and replenishment and replacement of consumable parts. The maintenance person is required to acquire sufficient knowledge, operating skills and maintenance skills for this product. The maintenance person shall carefully read this Instruction Manual and sufficiently understand the operation procedures, equipment characteristics, details of all operations and safety precautions before maintaining this product.

▪ Repair person (refer to the manufacturer that designs, manufactures and installs the equipment containing this product)

This person is the manufacturer that designs, manufactures and installs the piece of equipment incorporating this product and is allowed to perform work requiring special knowledge and skills such as installation, assembly, adjustment, and repair of this product. The repair person is required to have basic knowledge about pneumatic devices including materials, piping, electrotechnique and mechanics (level conforming to JIS B 8370 "General rule of design of pneumatic systems"), as well as knowledge of assembly of general machines. The persons shall carefully read this Instruction Manual and sufficiently understand the safety precautions before installing, assembling, adjusting and repairing this product.

Wearing protective equipment

Operator Safety shoes

Maintenance person Hard hat, protective goggles and safety shoes

Repair person Hard hat, protective goggles, safety shoes and other required protective equipment appropriate to their operations

Precautions on Product Use

WARNING

- **Perform the risk assessment of the whole equipment to ensure safety before using the product. In addition, perform the risk assessment from the user's standpoint based on the information on residual risk of the whole equipment by the end user and establish the safe operating procedures.**

This product is a pneumatically driven assistance device to be used as a mechanical device with a jig or attachment fitted to the tip of the arm.
- **When any abnormality such as vibration and noise occur, ensure the user's safety first and lock the arm in the vertical and rotation directions only when it is possible for safety.**

There is a risk of fatal accidents or serious damage to the user's body, product and equipment.
- **Do not modify the product or equipment without manufacturer's permission.**
- **Do not insert your fingers or hands into any gaps on the product or equipment.**
- **When placing (suspending) the objects to be transferred on the tip of the device (including the fitted attachment or jig), do not stack (suspend) them unevenly or in such a state that they may collapse.**
- **When manufacturing an attachment and designing a control circuit, provide an interlock circuit that can detect a workpiece to avoid unintended movement of the device.**
- **Do not leave the product or equipment during work or transfer.**

When releasing your hand from the product, lock it even if it is in a balanced state.
- **Do not operate the product in the state where the rotation lock has been manually released.**
- **Do not remove the rotation prevention bolt.**

If it is operated without the bolt, the internal pipe may be distorted and damaged.
- **The eyebolts and hexagon nuts (type 1) used for movement and installation cannot be reused. Discard them.**

When relocating, dismantling and discarding, use new eyebolts and hexagon nuts (type 1) (made of steel and conforming to the standards (ISO/IEC, JIS, etc.) in the user's country or region).

(The eyebolt blocks of the SCARA arm unit can be reused.)
- **When connecting the air pipe (electric wiring) from the pipe outlet to the air circuit (electric circuit), make sure that the air pipe and electric wiring are not crushed or tension stress is not applied.**
- **Use the product with all covers attached.**
- **When operating by the operator, maintenance person and repair person, wear the specified protective equipment.**
- **Do not use the product as a platform for lifting person or a ladder.**

There is a risk of falling.
- **Do not use the product beyond the maximum load capacity or moment load.**

There is a risk of fall accident.

 **WARNING**

- **Take the following measures to prevent accidents due to collisions.**
 - In the workplace, check that there are no obstacles or any other hazardous articles on the product or equipment.
 - Do not enter the movable range except for the person who operates it. When operating the tip of the arm, the arm moves separately and may hit people other than the operator.
 - Do not enter under the product or device when lifting the tip of the arm (including the fitted attachment or jig).
 - Before lowering the tip of the arm (including the fitted attachment or jig), make sure that there are no persons or obstacles under the product or device.
- **Take the following measures to prevent accidents when using a dolly.**
 - Do not use the product beyond the maximum overturning moment load.
 - Ground the four adjusters on a flat, paved ground before use.
 - Provide a brake mechanism on the casters of a dolly and apply the brakes when operating the product or device.
 - When using a dolly with outriggers, provide an interlock mechanism so that the product and device can be operated only when the outriggers are fully extended.
 - When moving a dolly, lower the tip of the arm to the lowermost position and fold the arm into the most compact size.
 - Do not move a dolly with a load on the tip of the arm (including the fitted attachment or jig).
 - When moving a dolly on a slope, consider the inertial force and take measures such as working with multiple people if necessary.
- **Don't use the unit of Power Arm series (Power Arm unit, Rotation unit, etc.) for other purpose.**
 - This product is exclusively for the Power arm series. Do not use it for any other purpose.

**CAUTION**

- **Store the product with all arms down to the lower end when leaving the product unused for a long period.**

The vertical lock of Power Arm is adopted an air block system that seals the internal cylinder chamber. If leaving Power Arm unused for a long period, the arms are fallen slowly because of small leakage from the cylinder chamber. If the product cannot store with all arms down to the lower end, contact CKD.
- **Do not disassemble the units.**

If the units are disassembled, their original performance and accuracy may not be restored.

If any unit must be overhauled, contact CKD.
- **Do not collide against the upper, lower or rotation end.**

Rubber cushions are built in at the upper, lower and rotation ends for moveable range control (vertical, rotation range). However, the rubber cushions can not absorb severe shock. Do not use the arm in such a way that it collides against the upper, lower or rotation end.
- **Do not stop rotating Power Arm by Rotation Lock unit.**

Rotation Lock unit of Option is just for holding the static position of Power Arm. Do not stop rotating motion of Power Arm because the mechanism is not for stopping rotating force.
- **Select Lock unit option when there is a risk that Power Arm is not kept in position due to inclination of the tip or swing caused by unlevelled.**

Select Lock unit option to keep Power Arm orientation. If not select Lock unit option, Power Arm may not keep the orientation.

Precautions on Specific Hazard Sources

There are structural and operational hazards specific to the product and equipment. The workers see the figure below and thoroughly understand the hazards and methods of avoiding them before operating and maintaining the product.



- Warning labels are applied to the following positions before shipment. To use the product safely, do not remove, stain or damage the labels.

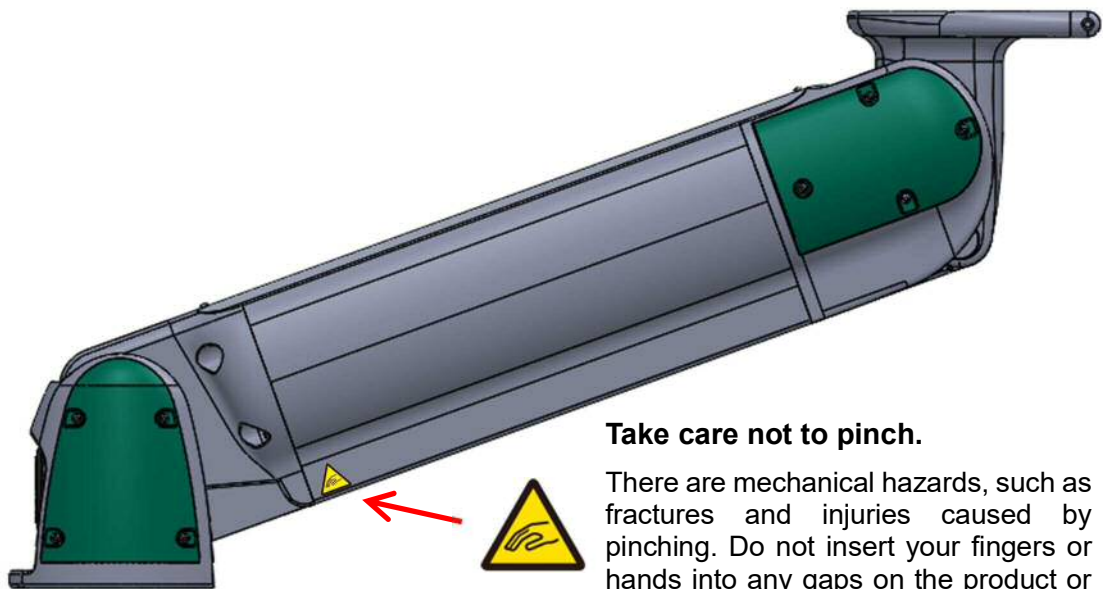

Take care not to pinch.

There are mechanical hazards, such as fractures and injuries caused by pinching. Do not insert your fingers or hands into any gaps on the product or equipment.

Precautions on Environment

Improper handling of the product may cause an impact on the environment. Install and use the product paying attention to the followings.

- When receiving and unpacking the product, dispose of unnecessary packaging materials in accordance with local laws and government ordinances.
- Failure to maintain the product and equipment may cause not only personal injuries and product or equipment troubles, but also environmental pollution. Implement the periodic maintenance of the product and equipment systematically and efficiently operate them.

When disposing of any consumable or periodic replacement parts, follow the local laws and government ordinances.

Precautions on Product Disposal

CAUTION

- When disposing of the product, follow the local laws and government ordinances.

CONTENTS

SM-A13989/5 is applied from serial No.230928 (from Sep.28.2023).

PREFACE	i
SAFETY INFORMATION	ii
Definition of Workers who Handles the Product	iii
Wearing protective equipment.....	iii
Precautions on Product Use	iv
Precautions on Specific Hazard Sources.....	vii
Precautions on Environment.....	vii
Precautions on Product Disposal.....	vii
CONTENTS	viii
1. PRODUCT OVERVIEW	1
1.1 Part Name	1
1.1.1 Product model number.....	1
1.1.2 Model number of each unit	2
1.2 Specifications	3
1.2.1 Product specifications	3
1.2.2 Movable range	4
1.2.3 Weight	4
1.2.4 Load capacity under pressure	5
1.3 Product component list.....	6
1.3.1 1-axis structure.....	6
1.3.2 2-axis structure.....	7
1.3.3 3-axis structure.....	8
1.4 Number of component units	9
1.4.1 Power Arm unit.....	9
1.4.2 Rotation unit.....	9
1.4.3 SCARA arm unit.....	10
1.4.4 Base plate	11
1.4.5 Rotation lock unit.....	11
2. System configuration	12
2.1 Operation range	12
2.2 Pneumatic pressure source	12
2.3 Air pipe	13
2.4 Recommended air circuit	14
2.4.1 Control at constant operating pressure (air circuit with one pressure mode).....	14
2.4.2 Control at constant operating pressure (air circuit with two pressure modes).....	15
2.4.3 Control by automatic operating pressure regulation.....	16
2.5 Moment load.....	17
2.6 When Rotation unit is to be assembled on Extension Arm.....	20
2.7 [When installed on a dolly] Overturning moment.....	21
3. INSTALLATION	22
3.1 Transportation	22
3.2 Unpacking.....	22
3.3 Storage Environment.....	23
3.4 Installation	24
3.4.1 Installation environment.....	24
3.4.2 Movement and installation of multi-axis product	25
3.5 Relocation of multi-axis product in use	27

4. Usage	30
4.1 Safety Instructions	30
4.2 Rotation Range	30
4.2.1 Restricting the rotation range	30
4.2.2 Maintenance hole on rotating unit	32
4.3 Manually Unlocking Method	33
4.3.1 In the vertical direction	33
4.3.2 Rotation direction in the case of model with rotation lock (option: L)	34
5. Assembly of unit product	35
5.1 Preparation	36
5.1.1 Required members	36
5.1.2 Required parts	37
5.2 Base plate	41
5.3 Rotation unit (lowermost)	42
5.4 Power Arm unit/ SCARA arm unit (lowermost arm)	44
5.5 Rotation unit (the second stage from the bottom)	47
5.6 Power Arm unit (the second arm from the bottom)	49
5.7 Rotation unit (the third stage from the bottom)	51
5.8 Power Arm unit (the third arm from the bottom)	53
5.9 Rotation unit (rotation mechanism at end)	55
5.10 Rotation lock unit (In the case of model with rotation lock (option: L))	58
5.11 Tubing	61
5.11.1 Selection according to option	61
5.11.2 Common to all models	63
5.11.3 Supplying air	68
6. MAINTENANCE AND INSPECTION	72
6.1 Periodic Inspection	72
Inspection item	72
6.2 Periodic maintenance parts	73
7. TROUBLESHOOTING	74
Problems, Causes, and Solutions	74
8. Disposal	75
8.1 Dismantling	75
8.2 Disposal	75
9. Declaration of CE conformity	76
10. WARRANTY PROVISIONS	77
10.1 Warranty Conditions	77
10.2 Warranty Period	77
10.3 Remarks	77

1. PRODUCT OVERVIEW

1.1 Part Name

1.1.1 Product model number

How to order

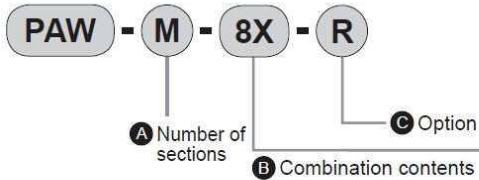

C Option: Bending direction

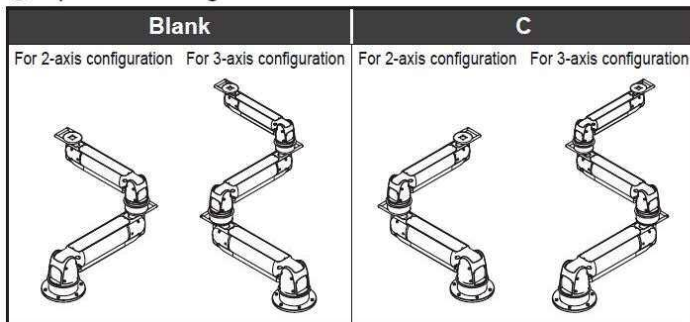

* C is not available for single axis (PAW-S).

C Option: Piping leadout direction

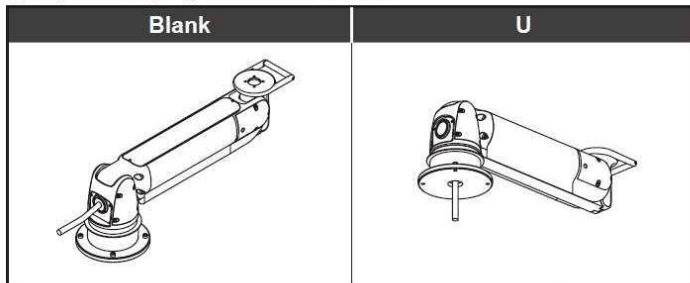

* Piping holes at the mounting surface center are required for U.

A Number of sections	
Single-axis	Multi-axis
S	M

Code	Description	S	M
B Combination contents			
8	ø80 single-axis	●	
X	ø100 single-axis	●	
Z	ø125 single-axis	●	
8S	ø80 + SCARA arm		●
XS	ø100 + SCARA arm		●
ZS	ø125 + SCARA arm		●
8X	ø80 + ø100		●
XZ	ø100 + ø125		●
8XS	ø80 + ø100 + SCARA arm		●
XZS	ø100 + ø125 + SCARA arm		●
8XZ	ø80 + ø100 + ø125		●
C Option			
L	Rotation lock mechanism *	●	●
R	Tip rotation mechanism	●	●
C	Bending direction (Refer to the figure at left)		●
U	Piping leadout direction (Refer to the figure at left)	●	●

* A mechanism designed to hold the force applied in rotational directions. It is not designed to stop dynamic rotational force.

Component units

Model number	Component units
PAW - S - 8	PAW-AU-8, PAW-RU-8, PAW-BP-8
PAW - S - X	PAW-AU-X, PAW-RU-X, PAW-BP-X
PAW - S - Z	PAW-AU-Z, PAW-RU-Z, PAW-BP-Z
PAW - M - 8S	PAW-AU-8, PAW-RU-8, PAW-SU-8S, PAW-RU-X, PAW-BP-X
PAW - M - XS	PAW-AU-X, PAW-RU-X, PAW-SU-XS, PAW-RU-Z, PAW-BP-Z
PAW - M - ZS	PAW-AU-Z, PAW-RU-Z, PAW-SU-ZS, PAW-RU-ZS, PAW-BP-ZS
PAW - M - 8X	PAW-AU-8, PAW-RU-8, PAW-AU-X, PAW-RU-X, PAW-BP-X
PAW - M - XZ	PAW-AU-X, PAW-RU-X, PAW-AU-Z, PAW-RU-Z, PAW-BP-Z
PAW - M - 8XS	PAW-AU-8, PAW-RU-8, PAW-AU-X, PAW-RU-X, PAW-SU-XS, PAW-RU-Z, PAW-BP-Z
PAW - M - XZS	PAW-AU-X, PAW-RU-X, PAW-AU-Z, PAW-RU-Z, PAW-SU-ZS, PAW-RU-ZS, PAW-BP-ZS
PAW - M - 8XZ	PAW-AU-8, PAW-RU-8, PAW-AU-X, PAW-RU-X, PAW-AU-Z, PAW-RU-Z, PAW-BP-Z

1.1.2 Model number of each unit

PowerArm unit

PAW-AU-()	
8	ø80
X	ø100
Z	ø125

Rotation unit

PAW-RU-()	
T	AU-8 tip part
8	AU-8 base part / AU-X tip part
X	AU-X base part / AU-Z tip part
Z	AU-Z base part
ZS	SU-Z base part

SCARA arm unit

PAW-SU-()	
8S	For AU-8 (AU-8 lower part)
XS	For AU-X (AU-X lower part)
ZS	For AU-Z (AU-Z lower part)

Base plate

PAW-BP-()	
8	AU-8 base part (assembled to RU-8)
X	AU-X base part (assembled to RU-X)
Z	AU-Z base part (assembled to RU-Z)
ZS	SU-Z base part (assembled to RU-ZS)

Rotation lock unit

PAW-LU

...Common to each rotation unit (1 unit is required for each rotation unit location)

Example: When configuring PAW-M-XZS-R

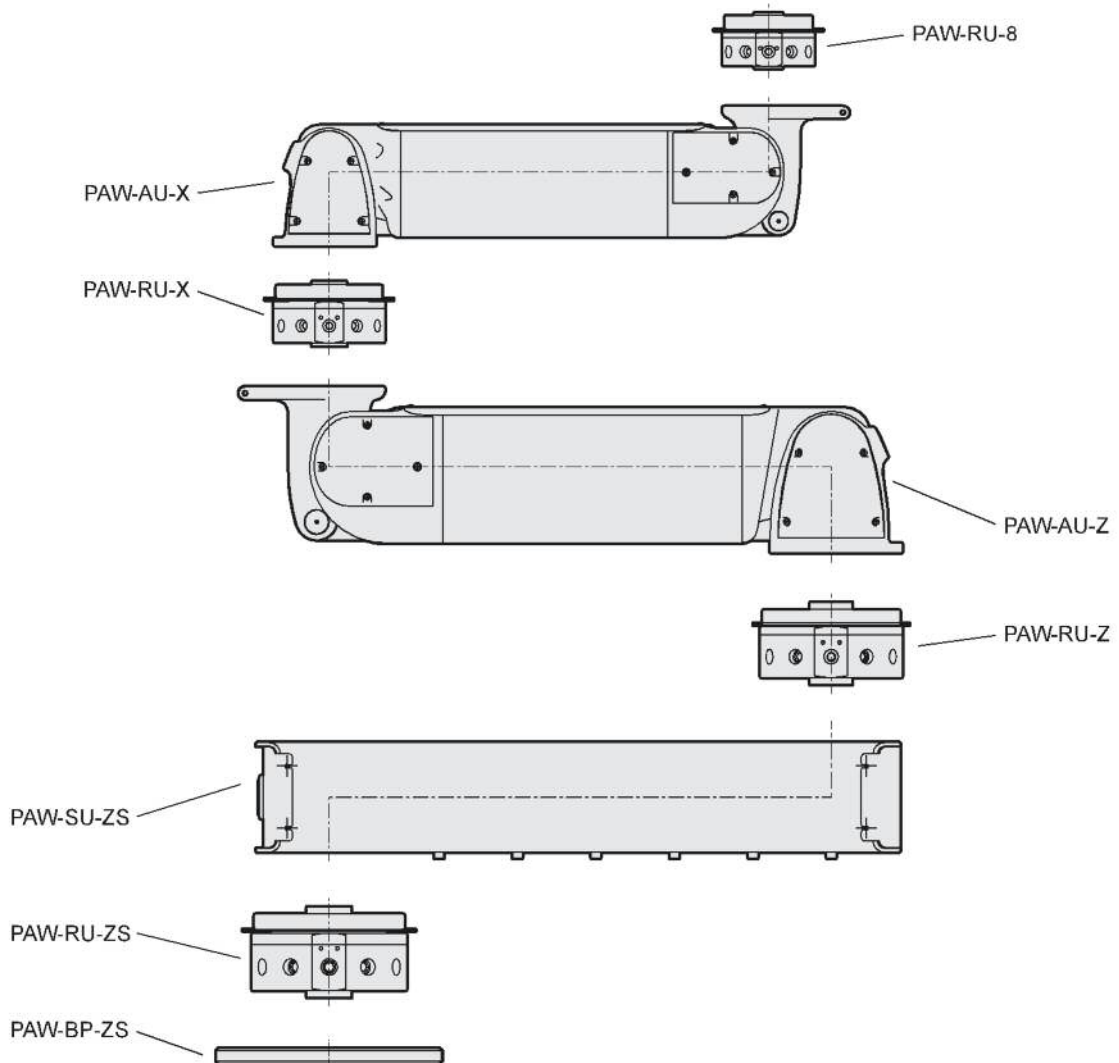

1.2 Specifications

1.2.1 Product specifications

Item		Model number	PAW-AU		
			8	X	Z
Bore size	mm		φ 80	φ 100	φ 125
Usage environment			Indoor use (degree of contamination: 3 excluding adverse environment with water or dust)		
Working fluid			Clean air ([Standard air circuit] Compressed air quality grade: equivalent to 1.5.1 to 1.6.1)		
Max. working pressure	MPa		0.7		
Min. working pressure	MPa		0.25 (0.35 when the option L (with rotation lock) is selected)		
Proof pressure	MPa		1.05		
Ambient temperature	°C		5 to 60		
Ambient humidity	%RH		30 to 85 (no condensation)		
Temperature during transportation and storage	°C		-10 to 60 (no freezing)		
Cushion			Rubber cushion		
Lubrication			Not available		
Load capacity kg <small>Note 1</small>	at 0.5 MPa		32	53	83
	When using the controller (PAW-B*)		28	46	72
Air consumption <small>Note 2</small>	L /min(ANR)		8	14	25

Note 1: The weight capacity varies depending on the supply pressure. Refer to "1.2.4 Weight capacity under pressure"
In the case of a multi-axis model, the weight capacity of the uppermost arm is regarded as the weight capacity of the multi-axis.
Indicates the load capacity with the optional tip rotation mechanism mounted.

Note 2: The air consumption represents a value with 1 return/min and 0.7 MPa working pressure.

Item		Model number	PAW-LU (option)		
Usage environment			Indoor use (excluding adverse environment with water or dust.)		
Working fluid			Clean air ([Standard air circuit] Compressed air quality grade: equivalent to 1.5.1 to 1.6.1)		
Max. working pressure	MPa		0.7		
Min. working pressure	MPa		0.35		
Proof pressure	MPa		1.05		
Ambient temperature	°C		5 to 60		
Ambient humidity	%RH		30 to 85 (no condensation)		
Temperature during transportation and storage	°C		-10 to 60 (no freezing)		
Lubrication			Not available		
Holding force	N		300		

1.2.2 Movable range

Single-axis	Movable range
	Vertical (mm)
PAW - S - 8	520
PAW - S - X	580
PAW - S - Z	650

Multi-axis	Movable range	
	Vertical (mm)	Horizontal (mm)
PAW - M - 8S	520	1200
PAW - M - XS	580	1400
PAW - M - ZS	650	1600
PAW - M - 8X	1100	1300
PAW - M - XZ	1230	1500
PAW - M - 8XS	1100	2000
PAW - M - XZS	1230	2300
PAW - M - 8XZ	1750	2100

Note: The horizontal movable range is the maximum value at the lower end of the vertical movable range.
For details on the movable range, refer to the external dimensions drawings in the catalog.

1.2.3 Weight

Product weight

	Weight (kg)	Weight including added options (kg)		
		With end rotation mechanism	With rotation lock	With end rotation mechanism and rotation lock
PAW - S - 8	27	4	0.5	5
PAW - S - X	38	5.5	0.5	6.5
PAW - S - Z	71	7.5	0.5	8.5
PAW - M - 8S	46	4	1.0	5.5
PAW - M - XS	77	5.5	1.0	7
PAW - M - ZS	123	7.5	1.0	9
PAW - M - 8X	58	4	1.0	5.5
PAW - M - XZ	102	5.5	1.0	7
PAW - M - 8XS	96	4	1.5	6
PAW - M - XZS	154	5.5	1.5	7.5
PAW - M - 8XZ	121	4	1.5	6

Unit weight

	Weight (kg)
PAW - AU - 8	14.0
PAW - AU - X	22.8
PAW - AU - Z	42.0
PAW - RU - T	4.0
PAW - RU - 8	5.1
PAW - RU - X	7.4
PAW - RU - Z	14.0
PAW - RU - ZS	18.1

	Weight (kg)
PAW - SU - 8S	11.0
PAW - SU - XS	17.8
PAW - SU - ZS	30.4
PAW - BP - 8	7.8
PAW - BP - X	7.8
PAW - BP - Z	14.9
PAW - BP - ZS	18.4
PAW - LU	0.4

1.2.4 Load capacity under pressure

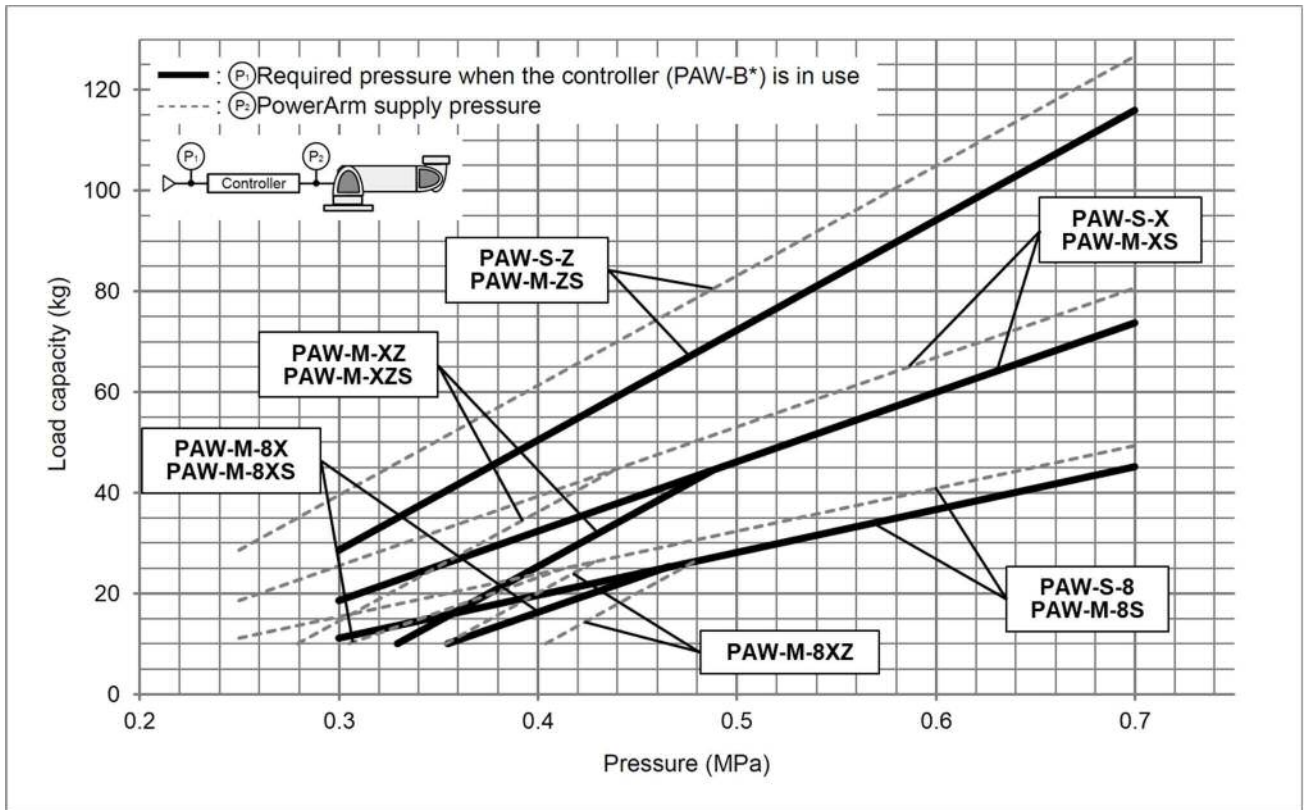

- * Indicates the load capacity with the optional tip rotation mechanism mounted.
- * Pressure supplied to the controller should be increased depending on the operating frequency and speed.
- * Load capacity is the sum of weights of the workpiece, attachment and operation box.
- * While the load capacity properties are such that it alters slightly according to the arm rise angle, this graph shows the lower limit values.

- As a characteristic of the Power Arm, there is a difference between raising and lowering forces depending on the angle. When releasing your hand from the operation handle out of the balance range, the arm will slowly move up or down to the balance range or upper end.

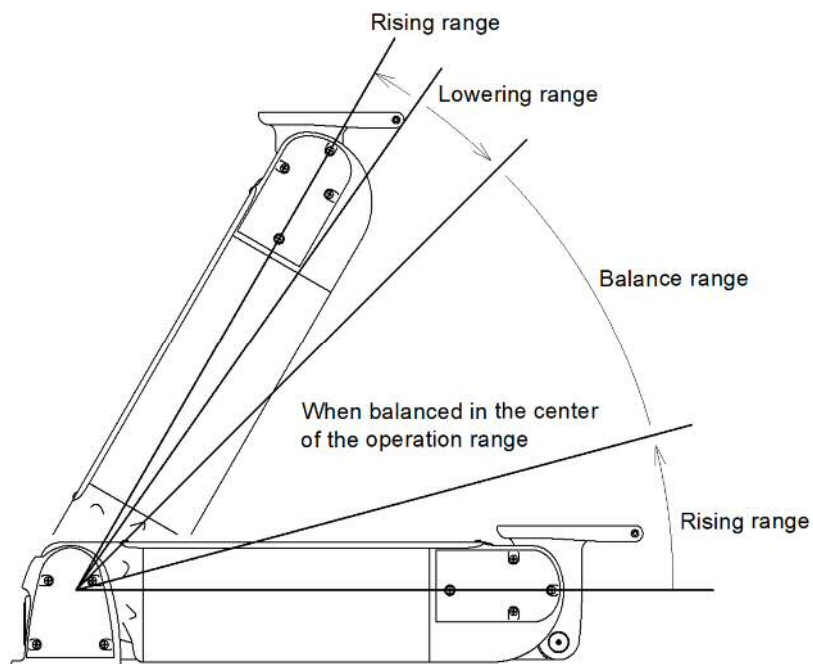

- If the arm must be held in any position in the vertical direction, release the pressure in the pipe for unlocking and lock the arm.

1.3 Product component list

1.3.1 1-axis structure

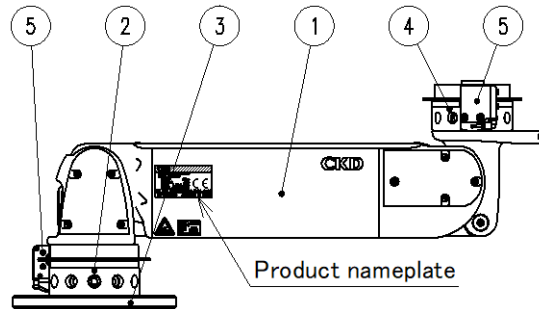

Product model number	①	②	③	④	⑤
PAW-S-8	Power Arm unit PAW-AU-8	Rotation unit PAW-RU-8	Base plate PAW-BP-8	Option (R) Rotation unit PAW-RU-T	Rotation lock unit PAW-LU
PAW-S-X	Power Arm unit PAW-AU-X	Rotation unit PAW-RU-X	Base plate PAW-BP-X	Rotation unit PAW-RU-8	
PAW-S-Z	Power Arm unit PAW-AU-Z	Rotation unit PAW-RU-Z	Base plate PAW-BP-Z	Rotation unit PAW-RU-X	
Number of component units	1	1	1	1	1 * When the options L and R are used, the number is 2.

Information shown on product nameplate (common to 2- and 3-axis models)

CKD

1. Product name	→ PRODUCTNAME PowerArm		9. CE mark <small>note</small>
2. Product model number	→ PAW-M-8XZ-LRCU		
3. Product weight	→ WEIGHT 126kg		
4. MAX. weight capacity	→ MAXLOAD 45kg		
5. Working pressure range	→ PRESS 0.35-0.7MPa		
6. Date of manufacture	→ SERIAL 20180101-01		
7. Contact	→ 250 Uji 2-Chome, Komaki, Aichi, Japan		
8. Company name	→ CKD Corporation	ASSEMBLED IN JAPAN	10. Country of manufacture (Country of assembly)

Date of manufacture
20180101-01

Year of manufacture	2018	Our control number
Month of manufacture	01	Day of manufacture

note: CE mark may not be affixed to some custom models.

1.3.2 2-axis structure

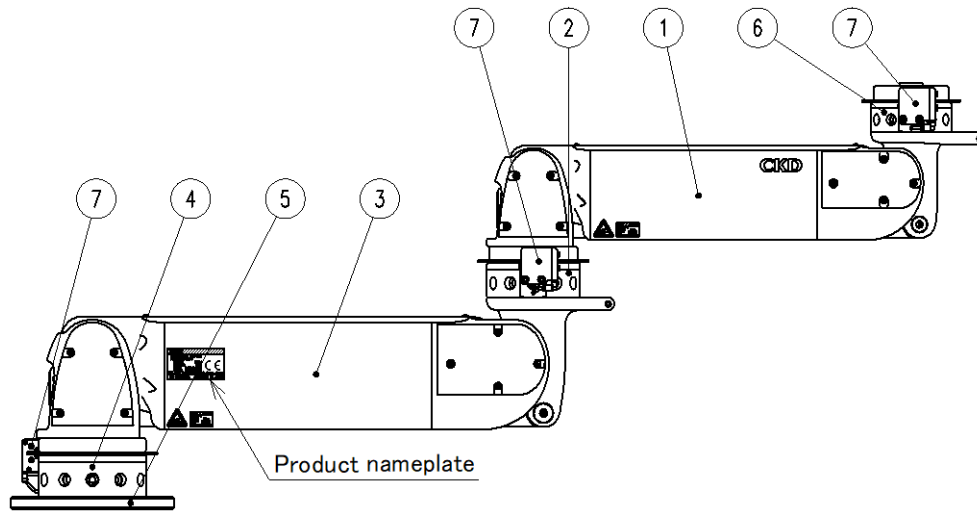

Product model number	①	②	③	④
PAW-M-8S	Power Arm unit PAW-AU-8	Rotation unit PAW-RU-8	SCARA arm unit PAW-SU-8S	Rotation unit PAW-RU-X
PAW-M-XS	Power Arm unit PAW-AU-X	Rotation unit PAW-RU-X	SCARA arm unit PAW-SU-XS	Rotation unit PAW-RU-Z
PAW-M-ZS	Power Arm unit PAW-AU-Z	Rotation unit PAW-RU-Z	SCARA arm unit PAW-SU-ZS	Rotation unit PAW-RU-ZS
PAW-M-8X	Power Arm unit PAW-AU-8	Rotation unit PAW-RU-8	Power Arm unit PAW-AU-X	Rotation unit PAW-RU-X
PAW-M-XZ	Power Arm unit PAW-AU-X	Rotation unit PAW-RU-X	Power Arm unit PAW-AU-Z	Rotation unit PAW-RU-Z
Number of component units	1	1	1	1

Product model number	⑤	⑥ Option (R)	⑦ Option (L)
PAW-M-8S	Base plate PAW-BP-X	Rotation unit PAW-RU-T	Rotation lock unit PAW-LU
PAW-M-XS	Base plate PAW-BP-Z	Rotation unit PAW-RU-8	
PAW-M-ZS	Base plate PAW-BP-ZS	Rotation unit PAW-RU-X	
PAW-M-8X	Base plate PAW-BP-X	Rotation unit PAW-RU-T	
PAW-M-XZ	Base plate PAW-BP-Z	Rotation unit PAW-RU-8	
Number of component units	1	1	2 * When the options L and R are used, the number is 3.

1.3.3 3-axis structure

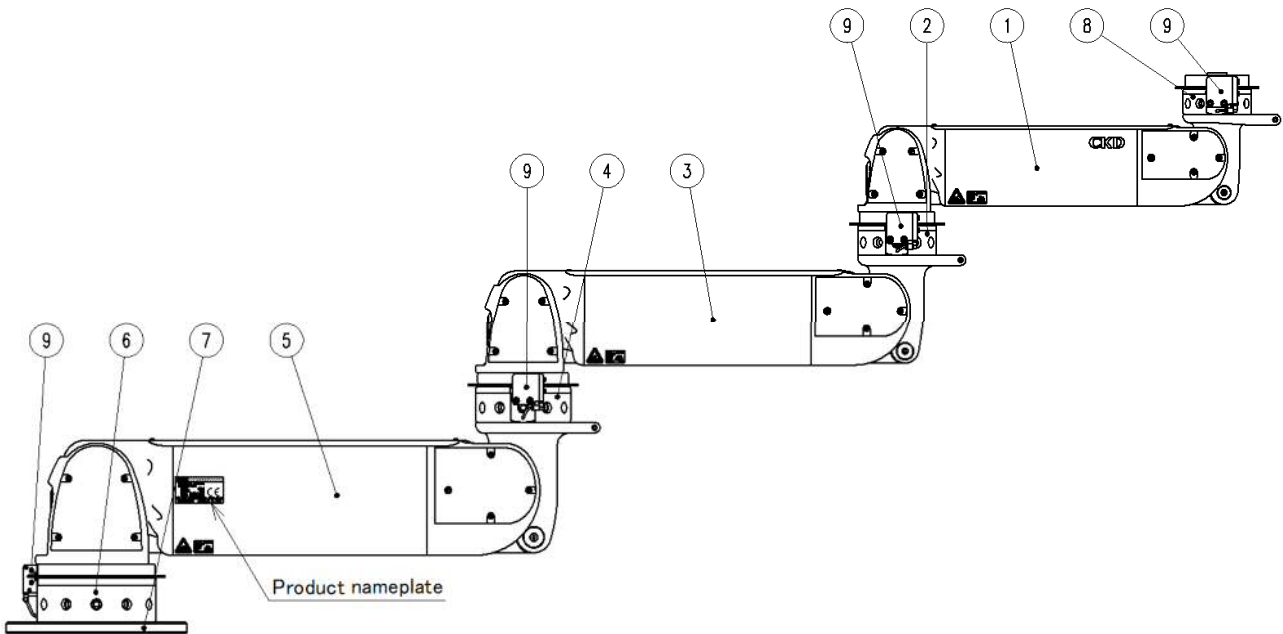

Product model number	①	②	③	④	⑤	⑥
PAW-M-8XS	Power Arm unit PAW-AU-8	Rotation unit PAW-RU-8	Power Arm unit PAW-AU-X	Rotation unit PAW-RU-X	SCARA arm unit PAW-SU-XS	Rotation unit PAW-RU-Z
PAW-M-XZS	Power Arm unit PAW-AU-X	Rotation unit PAW-RU-X	Power Arm unit PAW-AU-Z	Rotation unit PAW-RU-Z	SCARA arm unit PAW-SU-ZS	Rotation unit PAW-RU-ZS
PAW-M-8XZ	Power Arm unit PAW-AU-8	Rotation unit PAW-RU-8	Power Arm unit PAW-AU-X	Rotation unit PAW-RU-X	Power Arm unit PAW-AU-Z	Rotation unit PAW-RU-Z
Number of component units	1	1	1	1	1	1

Product model number	⑦	⑧ Option (R)	⑨ Option (L)
PAW-M-8XS	Base plate PAW-BP-Z	Rotation unit PAW-RU-T	Rotation lock unit PAW-LU
PAW-M-XZS	Base plate PAW-BP-ZS	Rotation unit PAW-RU-8	
PAW-M-8XZ	Base plate PAW-BP-Z	Rotation unit PAW-RU-T	
Number of component units	1	1	3 * When the options L and R are used, the number is 4.

1.4 Number of component units

1.4.1 Power Arm unit

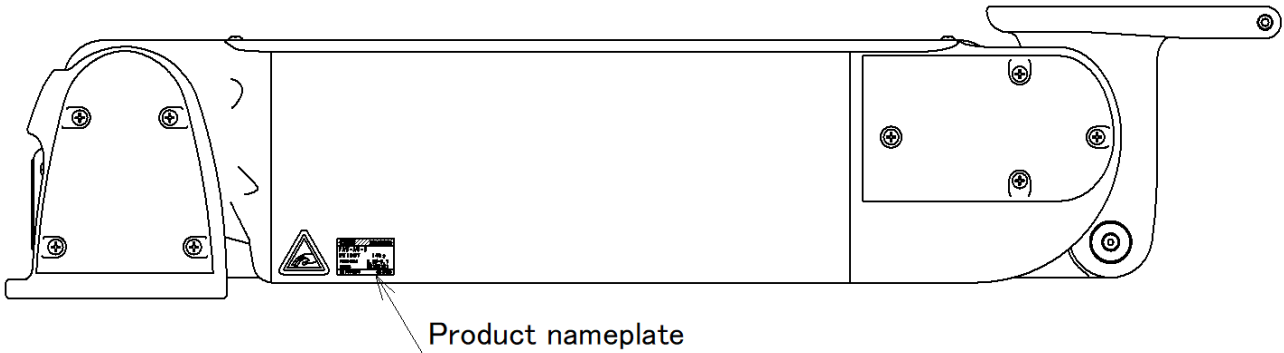

-Information shown on unit nameplate

	CKD	CYLINDER	
1. Product name	PAW-AU-8		
2. Product weight	WEIGHT	14kg	
3. Working pressure range	PRESS(MPa)	0.25-0.7	
4. Date of manufacture	SERIAL	2018010101	
5. Company name	CKD Corporation		6. Country of manufacture (Country of assembly)
			MADE IN CHINA

Date of manufacture
 2018010101
 Year of manufacture | Month of manufacture | Our control number | Day of manufacture

1.4.2 Rotation unit

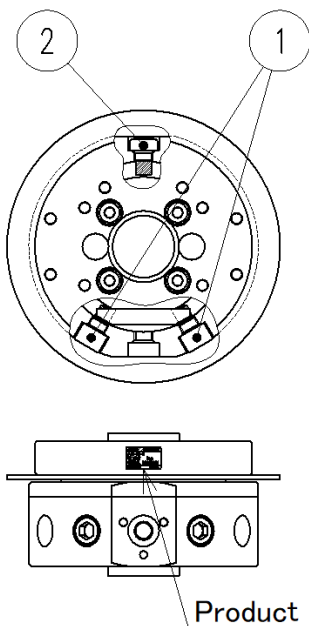

-Information shown on unit nameplate

	CKD	CYLINDER	
1. Product name	PAW-RU-8		
2. Product weight	WEIGHT	6kg	
3. Date of manufacture	SERIAL	2018010101	
4. Company name	CKD Corporation		5. Country of manufacture (Country of assembly)
			MADE IN CHINA

Date of manufacture
 2018010101
 Year of manufacture | Month of manufacture | Our control number | Day of manufacture

Rotation unit maintenance parts

Unit model number	① Stopper bolt kit	② Rotation preventing bolt kit
PAW-RU-T	PAW-RU-T-STB-KIT	PAW-RU-T-ARB-KIT
PAW-RU-8	PAW-RU-8-STB-KIT	PAW-RU-8-ARB-KIT
PAW-RU-X	PAW-RU-X-STB-KIT	PAW-RU-X-ARB-KIT
PAW-RU-Z	PAW-RU-Z-STB-KIT	PAW-RU-Z-ARB-KIT
PAW-RU-ZS	PAW-RU-ZS-STB-KIT	PAW-RU-ZS-ARB-KIT
Number contained	2	1

1.4.3 SCARA arm unit

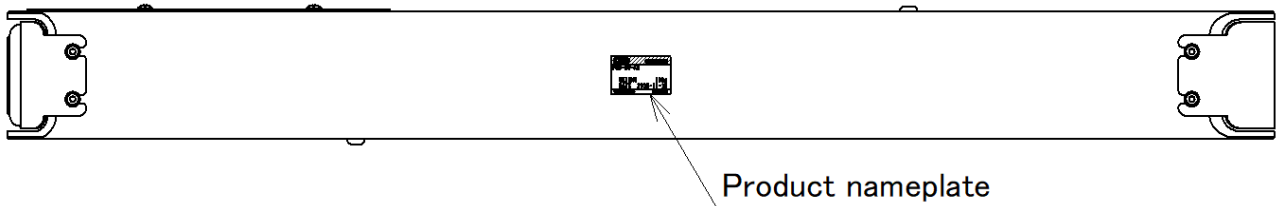

Information shown on unit nameplate

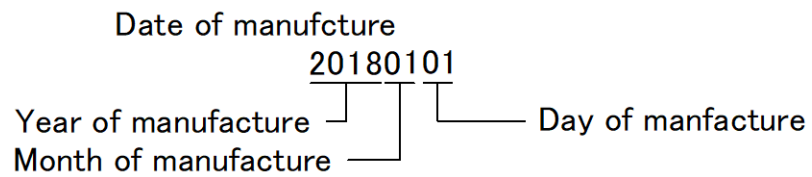
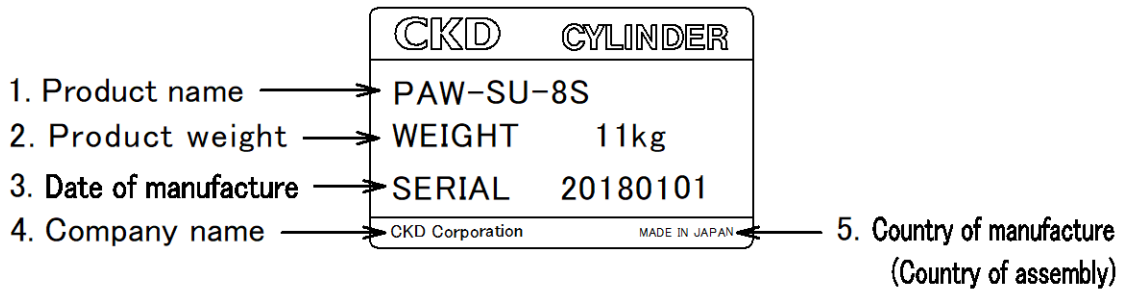

1.4.4 Base plate

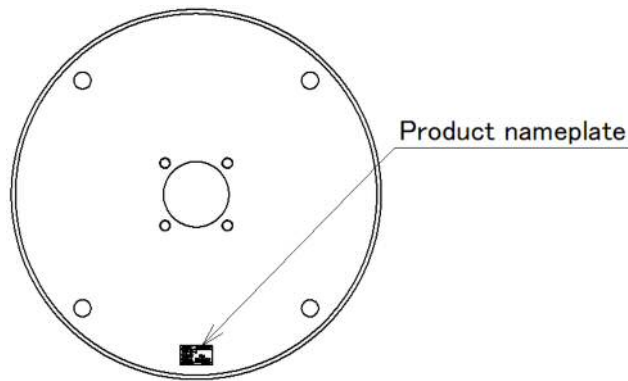

Information shown on unit nameplate

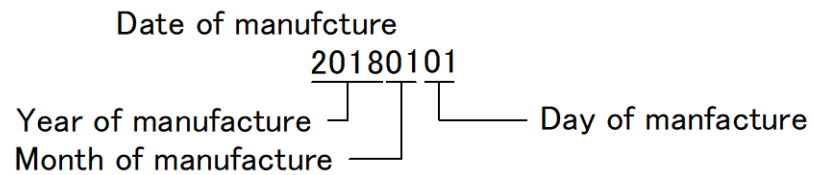
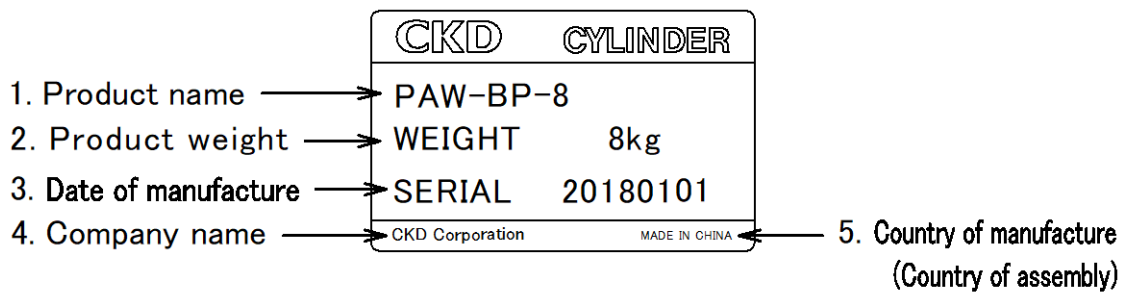

1.4.5 Rotation lock unit

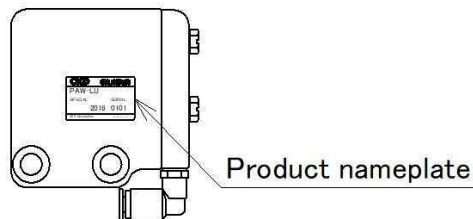

Information shown on unit nameplate

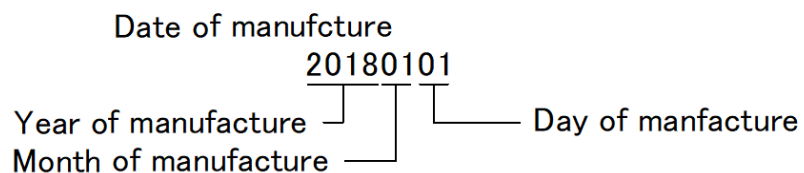
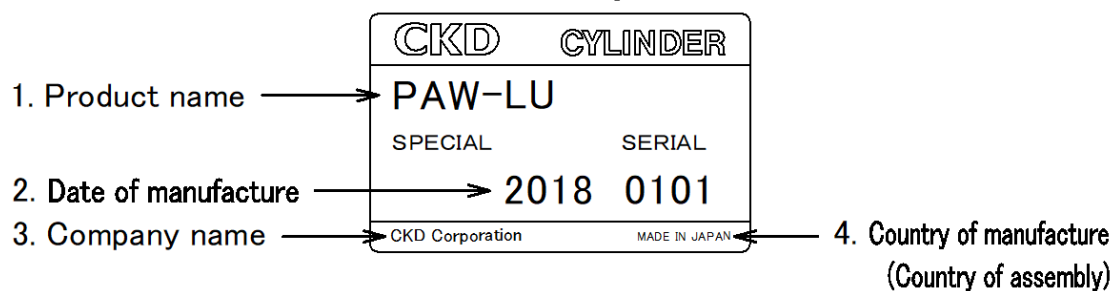

2. System configuration

2.1 Operation range



- Rubber cushions are built in at the rotation ends for rotation range limit. However, the rubber cushions can not absorb severe shock. Do not use the arm in such a way that it collides against the rotation end.

Therefore, when designing working layout, keep enough operation buffer and prevent colliding against the rotation end.

- This product is exclusively for the Power arm series. Do not use it for any other purpose.



- Select Lock unit option to keep Power Arm orientation. If not select Lock unit option, Power Arm may not keep the orientation if installation surface is not leveled etc.

2.2 Pneumatic pressure source

When using the product, supply pneumatic pressure in the range from the required pressure of +0.05 MPa to 0.7 MPa (refer to “1.2.4 Weight capacity under pressure”)

Supply clean air ([standard air circuit] compressed air quality grade: equivalent to 1.5.1 to 1.6.1).

Standard air circuit

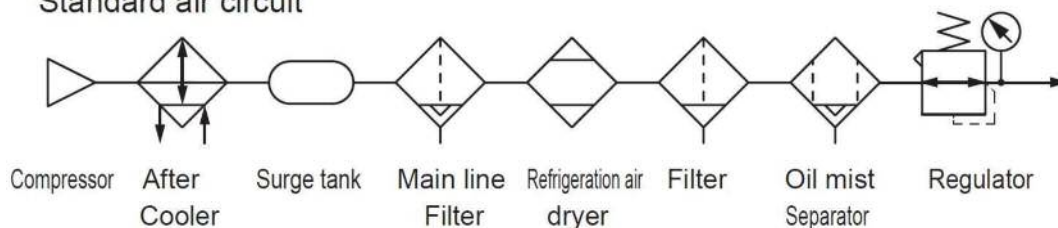

It is unnecessary to lubricate the product. Lubrication may cause troubles. Do not lubricate it.

If carbides (carbon or tarry substances) in the compressor oil enter the circuit, the solenoid valves and cylinders may cause malfunction. Make sure to maintain and inspect the compressor carefully.



- Connect the pneumatic pipe securely so that it will not be disconnected during use.
- Do not crush the pipe or apply tension stress to it.

2.3 Air pipe

- Pipe for cylinder (PAW-8: tube diameter $\varnothing 8$, PAW-X and PAW-Z: tube diameter $\varnothing 10$)

This pipe is connected to the air cylinder in the Power Arm unit through the block valve FPV contained in the Power Arm unit.

Supply air controlled in a balanced state by the precision regulator (electro-pneumatic regulator).

- Pipe for unlocking (outer diameter $\varnothing 4$)

This pipe is connected to the pilot signal port of the block valve FPV contained in the Power Arm unit.

When air is supplied, the valve will open and the air controlled in a balanced state by the precision regulator (electro-pneumatic regulator) will be supplied to the air cylinder in the Power Arm unit.

When air is discharged, the valve will close and the air will be enclosed in the air cylinder, which will function as a lock in the vertical direction.



- The locking position may change in the vertical direction to a certain degree due to compression and expansion of the enclosed air.



- Supply air to the pipe for unlocking one second or more after supplying the air controlled in a balanced state to the pipe for cylinder. If air is supplied simultaneously, Power Arm will be unlocked before the pressure in the air cylinder in the Power Arm unit increases, and the arm may fall.
- Take care not to crush the piping or apply tension stress to it.

[In the case of model with rotation lock (option: L)]

The pipe is branched in the Power Arm unit (SCARA arm unit) and connected to the unlocking port of the rotation lock unit.

When air is supplied, the arm will be unlocked and can rotate freely.

When air is discharged, it will function as a lock in the rotation direction.



- The arm is locked mechanically by inserting the lock shoe and almost no backlash will occur in the rotation direction.

2.4 Recommended air circuit

⚠ WARNING

- When creating the circuit, install safety mechanisms without fail and perform risk assessment of the equipment.

If the safety mechanisms are not contained in the circuit, serious accidents may be caused by jumping up due to fall of transfer object or sudden lowering due to switching operation failure.

Design safe equipment and circuit to avoid unexpected malfunctions.



- The locking position may change in the vertical direction to a certain degree due to compression and expansion of the enclosed air.

2.4.1 Control at constant operating pressure (air circuit with one pressure mode)

One precision regulator is set and a certain weight is constantly maintained in a balanced state.

This control is suitable for assisting a jig or tool that will not change in weight.

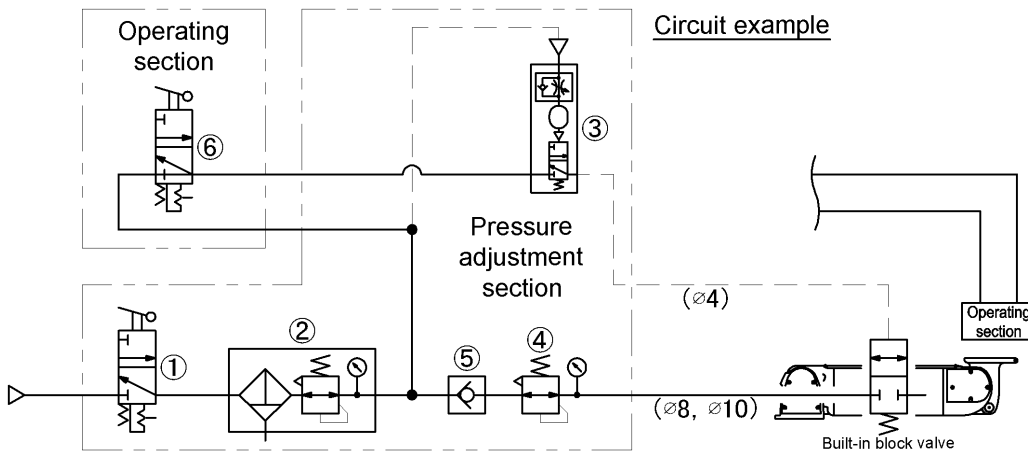

No.	Recommended equipment name	Model No.	Remarks
1	Shut-off valve	V3000-10-W	
2	Filter/regulator	W3100-10-W	
3	Timer (on-delay)	PRT-E12	For operation preparation, Set time one second or more
4	Precision regulator	RP2000-10-08	For balance pressure adjustment
5	Check valve	CHV2-10	For holding the position in an emergency
6	select Select valve	MS-00-SE1	Switch between operation and stop
	Mechanical valve	MS-00-PP	[Drive only while pressing]

<Selection example>
Select by the user

2.4.2 Control at constant operating pressure (air circuit with two pressure modes)

Two modes of balanced state are set in advance with two precision regulators for the presence and absence of objects transferred and the mode can be changed with a switch.

This control is suitable for lot production that the same product is continuously transported.

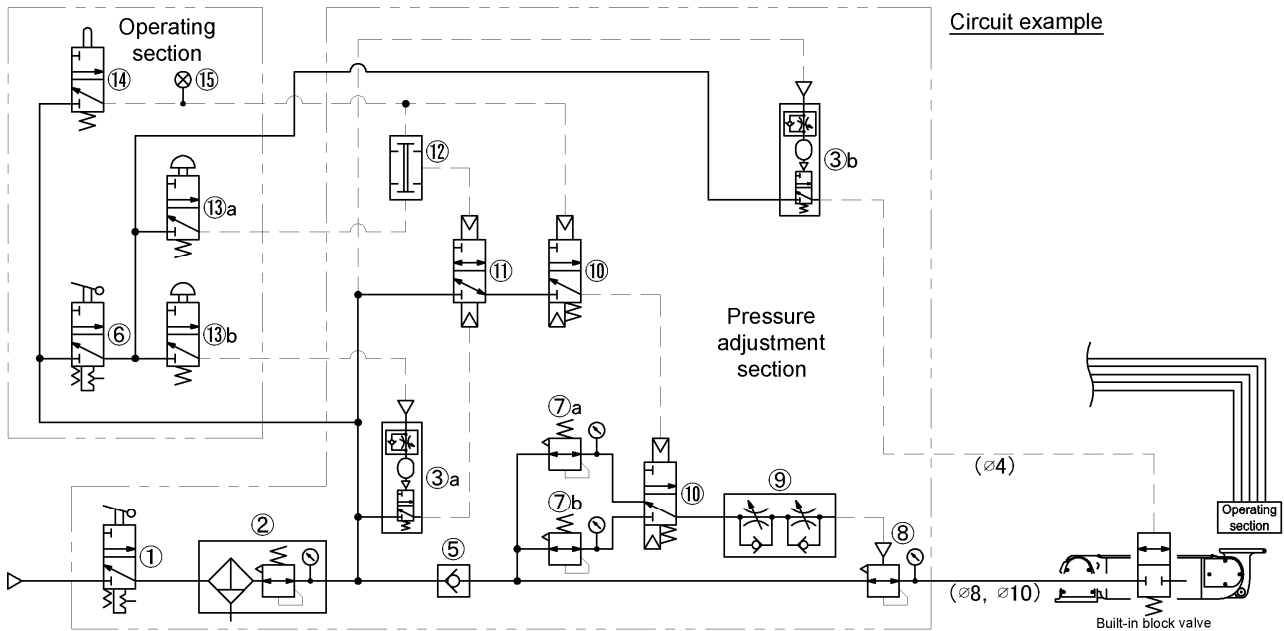

No.	Recommended equipment name	Model No.	Remarks
1	Shut-off valve	V3000-10-W	
2	Filter/regulator	W3100-10-W	
3	Timer (on-delay)	PRT-E12	Press and hold to switch to a balanced state without objects transferred
			For operation preparation, Set time one second or more
5	Check valve	CHV2-10	For holding the position in an emergency
7	Precision regulator	RP1000-8-07	For balance pressure adjustment without objects transferred
			For balance pressure adjustment with objects transferred
8	Precision regulator	RP2000-10-FL316286	
9	In-out speed controller	SCD2-04-H44	Switch the speed adjustment with or without objects transferred
10	Master valve	3KA111-M5	
11	Master valve	3KA121-M5	
12	AND valve	PLL-B12	
6	Select valve	MS-00-SE1	Switch between operation and stop
	Mechanical valve	MS-00-PP	Drive only while pressing
13	Push button valve	MS-00-PB1	For switching with objects transferred
			For switching without objects transferred (press and hold)
14	Roller lever valve	MS-00-RL	Seated switch for objects transferred
15	Air lamp	PXV-M151	ON indication when seated

<Selection example>
Select by the user



- The circuit shown above contains safety mechanisms such as the seating switch for objects transferred and balanced state switch by pressing and holding the button.



2.4.3 Control by automatic operating pressure regulation

The weight of the objects transferred is detected by the load cell installed at the tip of the arm and the pressure is regulated by the electro-pneumatic regulator according to the weight.

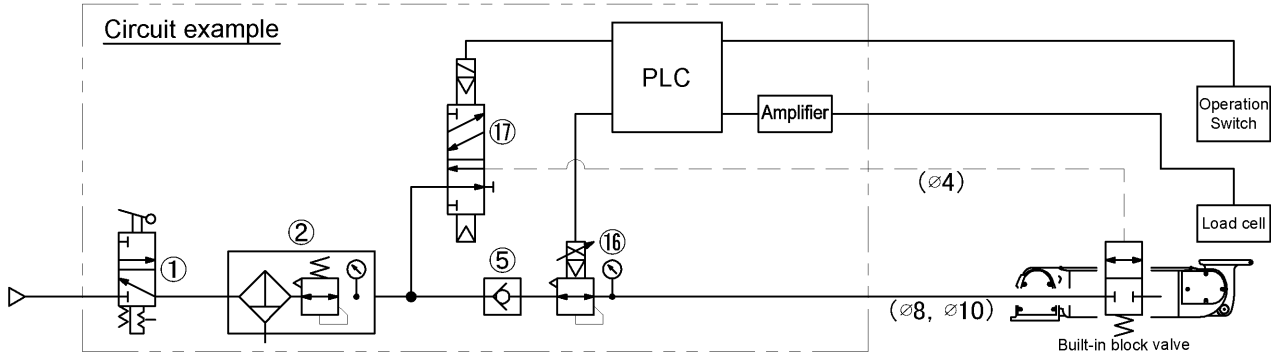
This control is suitable for handling various kinds of objects transferred differing in weight.



No.	Recommended equipment name	Model No.	Remarks
1	Shut-off valve	V3000-10-W	
2	Filter/regulator	W3100-10-W	
5	Check valve	CHV2-10	For holding the position in an emergency
16	Digital electro pneumatic regulator	EVD-3900-110	For balance pressure adjustment for objects transferred
17	Valve	3GA210R-C4	Switch between operation and stop

- 
 - The electrical wiring to the tip of the arm can be laid through inside Power Arm.
- 
 - When laying the electrical wiring through inside the arms, use a robot cable (movable cable) for machine use with an outside diameter of 12 mm or less.
 - When laying the cable, be careful not to twist or bend it or entangle it with the air pipes.
 - When the electrical wiring is laid in Power Arm, use the product at 24 V AC/DC or less.
 - Place and secure the electrical wiring separately from the air pipes.

2.5 Moment load

Calculate the moment load from the weight of the jig and workpiece to be fitted to the end and the length and weight of the arm (hereinafter, referred to as the extension arm) that will overhang the Power Arm mount during use.

[In the case of single-axis Power Arm unit]

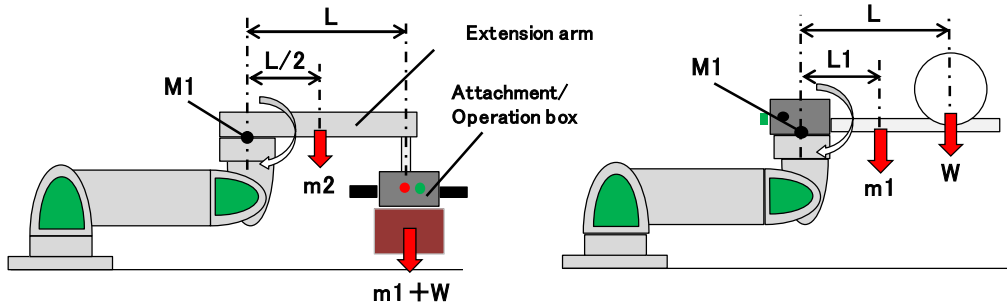

When the extension arm is installed
 $M1 = (m1 + W) \times L + m2 \times L / 2$

m1 : Weight of attachment/operation box
 m2 : Weight of extension arm
 W : Weight of workpiece
 L : Distance from Power Arm mount to gravity center of attachment/workpiece

When the attachment is offset
 $M1 = m1 \times L1 + W \times L$

m1 : Weight of attachment/operation box
 W : Weight of workpiece
 L1 : Distance from Power Arm mount to gravity center of attachment/operation box
 L : Distance from Power Arm mount to gravity center of workpiece



- Design the workpiece, attachment and extension arm so that the moment load is lower than the value shown in the following table.

Model number	M1 (N·m)
PAW-S-8	350
PAW-S-X	550
PAW-S-Z	900
PAW-M-8S	350
PAW-M-XS	550
PAW-M-ZS	900

- Calculate only for the Power Arm unit.

[In the case of 2-axis Power Arm unit]

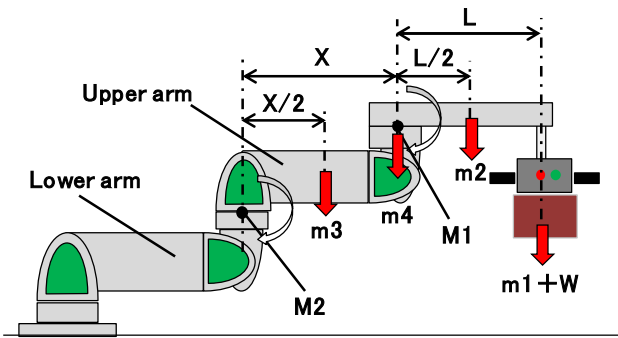

When the extension arm is installed

① Moment applied to upper arm

$$M1 = (m1 + W) \times L + M2 \times L / 2$$

② Moment applied to lower arm

$$M2 = (m1 + W) \times (L + X) + m2 \times (L / 2 + X) + m3 \times X / 2 + m4 \times X$$

m1 : Weight of attachment/operation box

m2 : Weight of extension arm

m3 : Weight of Power arm

PAW-AU-8 : 14kg

PAW-AU-X : 23kg

PAW-AU-Z : 42kg

*Weight is rounded up

m4 : Weight of rotation unit

PAW-RU-T : 4kg

PAW-RU-8 : 6kg

PAW-RU-X : 8kg

*Weight is rounded up

W : Weight of workpiece

L : Distance from Power Arm mount to gravity center of attachment/workpiece

X : Length of Power Arm

PAW-AU-8 : 600mm

PAW-AU-X : 700mm

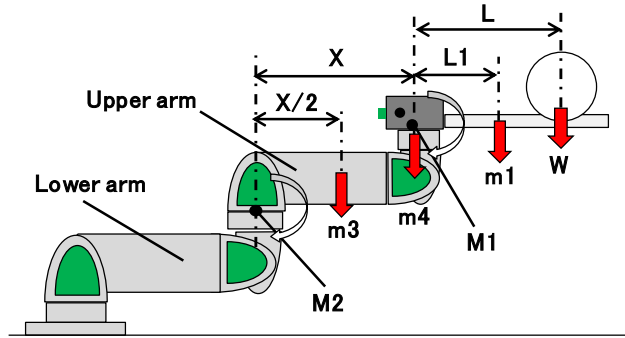

When the attachment is offset

① Moment applied to upper arm

$$M1 = m1 \times L1 + W \times L$$

② Moment applied to lower arm

$$M2 = W \times (L + X) + m1 \times (L1 + X) + m3 \times X / 2 + m4 \times X$$

m1 : Weight of attachment/operation box

m3 : Weight of Power arm

PAW-AU-8 : 14kg

PAW-AU-X : 23kg

PAW-AU-Z : 42kg

*Weight is rounded up

m4 : Weight of rotation unit

PAW-RU-T : 4kg

PAW-RU-8 : 6kg

PAW-RU-X : 8kg

*Weight is rounded up

W : Weight of workpiece

L1 : Distance from Power Arm mount to gravity center of attachment/operation box

L : Distance from Power Arm mount to gravity center of workpiece

X : Length of Power Arm

PAW-AU-8 : 600mm

PAW-AU-X : 700mm



- Design the workpiece, attachment and extension arm so that the moment load is lower than the value shown in the following table.

Model number	Upper joint M1(N·m)	Lower joint M2(N·m)
PAW-M-8X	350	550
PAW-M-XZ	550	900
PAW-M-8XS	350	550
PAW-M-XZS	550	900

- Calculate only for the Power Arm unit.

[In the case of 3-axis Power Arm unit]

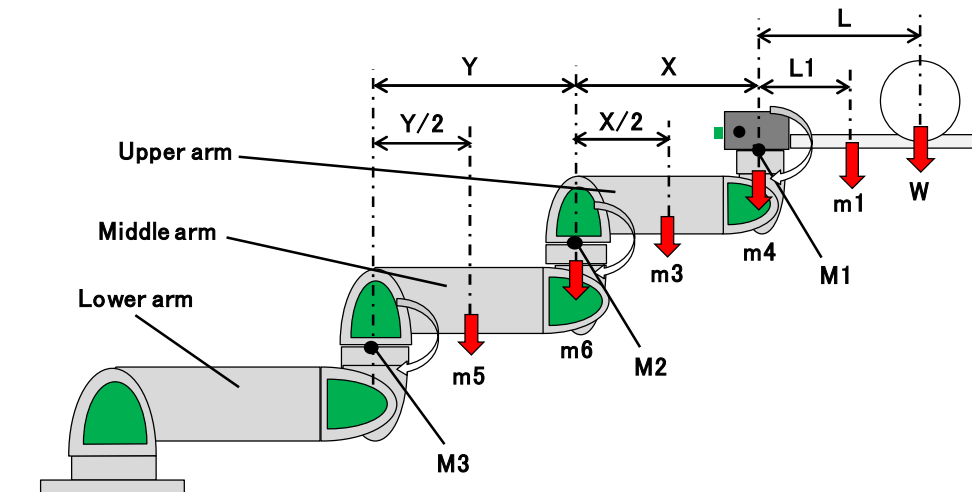

When the attachment is offset

① Moment applied to upper arm

$$M1 = m1 \times L1 + W \times L$$

② Moment applied to middle arm

$$M2 = W \times (L + X) + m1 \times (L1 + X) + m3 \times X / 2 + m4 \times X$$

③ Moment applied to lower arm

$$M3 = W \times (L + X + Y) + m1 \times (L1 + X + Y) + m3 \times (X / 2 + Y) + m4 \times (X + Y) + m5 \times Y / 2 + m6 \times Y$$

m1 : Weight of attachment/operation box

m3 : Weight of Power arm PAW-AU-8: 14kg *Weight is rounded up

m4 : Weight of rotation unit PAW-RU-T: 4kg *Weight is rounded up

m5 : Weight of Power arm PAW-AU-X: 23kg *Weight is rounded up

m6 : Weight of rotation unit PAW-RU-8: 6kg *Weight is rounded up

W : Weight of workpiece

L1 : Distance from Power Arm mount to gravity center of attachment/operation box

L : Distance from Power Arm mount to gravity center of workpiece

X : Length of Power Arm PAW-AU-8: 600mm

Y : Length of Power Arm PAW-AU-X: 700mm

- Design the workpiece, attachment and extension arm so that the moment load is lower than the value shown in the following table.



Model number	Upper joint M1(N·m)	Middle joint M2(N·m)	Lower joint M3(N·m)
PAW-M-8XZ	350	550	900

- Calculate only for the Power Arm unit.

2.6 When Rotation unit is to be assembled on Extension Arm.

When Rotation unit is to be installed on Extension Arm, allowable moment load of the rotation unit is different by installing direction. Use Power Arm within allowable vertical load and moment load.

[Installed upward]

[Installed downward]

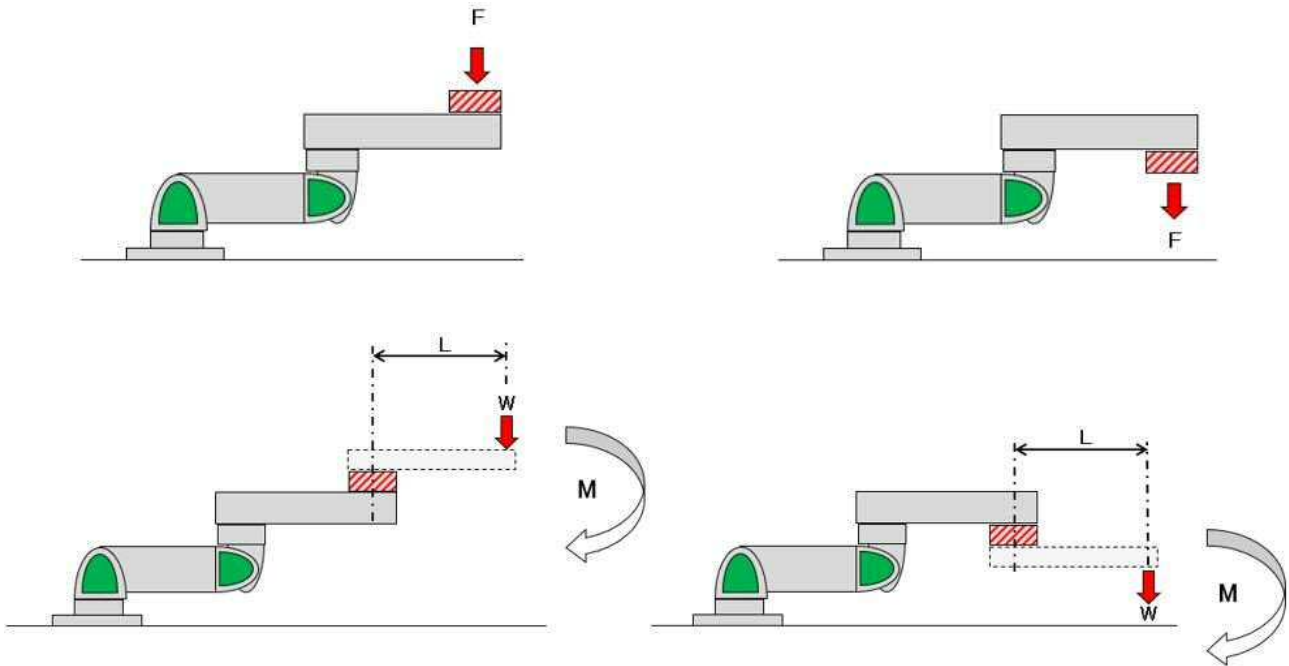

Item	Model number	PAW-RU				
		T	8	X	Z	ZS
Allowable vertical load (F)	N	500	900	1500	2100	2800
Allowable moment load (M)	Upward N·m	350	550	900	2100	3400
	Downward N·m	200	310	Not available	Not available	Not available

Allowable moment load : $M=W \times L$

2.7 [When installed on a dolly] Overturning moment

Calculate the overturning moment from the weight of the jig and workpiece to be fitted to the end and the length and weight of the extension arm, and design and use the arm under conditions where it will not overturn.

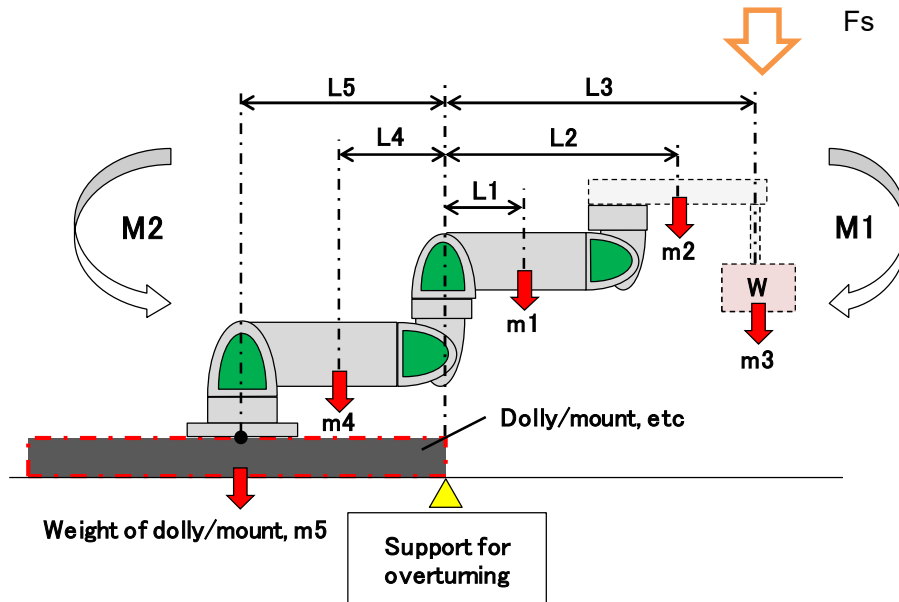

$M_2 = m_4 \times L_4 + m_5 \times L_5$
 Moment applied in holding direction when workpiece is hoisted

$M_1 = m_1 \times L_1 + m_2 \times L_2 + m_3 \times L_3$
 Moment applied in overturning direction when workpiece is hoisted

WARNING

- Design and use the arm under conditions where the overturning moment load meets the following formula.

$$M_2 > M_1 + F_s \times L_3 \text{ (safety margin)}$$

F_s : Outside force (N) $F_s = 80\text{kg} \times 9.8$

3. INSTALLATION

3.1 Transportation

The product is packed in any of the following two styles.

- Product: Crating
- Each unit: Cardboard box

All products and the following units weigh over 15 kg after packing.

- Power Arm unit..... PAW-AU-8, PAW-AU-X, PAW-AU-Z
- Rotation unit PAW-RU-Z, PAW-RU-ZS
- SCARA arm unit.... PAW-SU-XS, PAW-SU-ZS
- Base plate..... PAW-BP-Z, PAW-BP-ZS



- Any item packed in a cardboard box exceeding 15 kg shall be lifted up by two or more persons and transported on a dolly or the like.
- Wooden crated items shall be transported by any of the following methods: hoisting the product with a crane or lifting with a forklift or handlift.
- The crane, forklift and handlift shall be operated by experts (the crane and forklift shall be operated by qualified experts) wearing protective equipment such as helmets and safety shoes and the lifting height shall be the minimum necessary.
- When hoisting or forklifting the product, support the lowermost surface. Hoist or lift it in a well-balanced state (at first, hoist or lift it slightly and make sure that it is well-balanced before transporting).



- Do not transport the product by any other method other than the hoisting the product with a crane or lifting with a forklift or handlift.
- It is prohibited to stack wooden crate packages.

3.2 Unpacking



- Each crate or box must be unpacked by a repair person after checking that the top side is up.



- For the crates, nails and staplers are used. When handling the crates, wear protective equipment such as a helmet, safety shoes, long-sleeved work clothing and protective gloves.
- After unpacking, dispose of unnecessary packing materials in accordance with the local laws and government ordinances.

3.3 Storage Environment

The ambient temperature during storage should be -10°C to 60°C (no freezing).

The ambient humidity shall be 30%RH to 85%RH (no condensation).

Do not store the product in an environment where:

- It is exposed to direct sunlight or radiant heat
- Firearms are nearby
- Water or oil can splash onto the product
- Atmosphere contains cutting chips, foreign matters or duct
- Corrosive or combustible gas are generated
- It is subject to vibrations or shocks
- X-ray is used
- Atmosphere contains a lot of salt or organic solvents

3.4 Installation

3.4.1 Installation environment

When installing the product on an existing concrete floor (the floor shall be reinforced with bars with a diameter of 6 or more), use chemical anchors (made by Nihon Decoluxe Co., Ltd.).

For the type of chemical anchor, anchor reinforcing bar size, quantity and installation dimensions, refer to the table and figure below. For the construction method (drilling method), refer to the instruction manual for the chemical anchor.

	Product model number	Type of chemical anchors	Anchor bar dimensions	Quantity
①	PAW-S-8 PAW-S-X PAW-M-8S PAW-M-8X	R-10N or R-10LN	W3/8" or M10	4
②	PAW-S-Z PAW-M-XS PAW-M-XZ PAW-M-8XS PAW-M-8XZ	R-12N or R-12LN	W1/2" or M12	6
③	PAW-M-ZS PAW-M-XZS	R-16N or R-16LN	W5/8" or M16	8

Placement dimensions

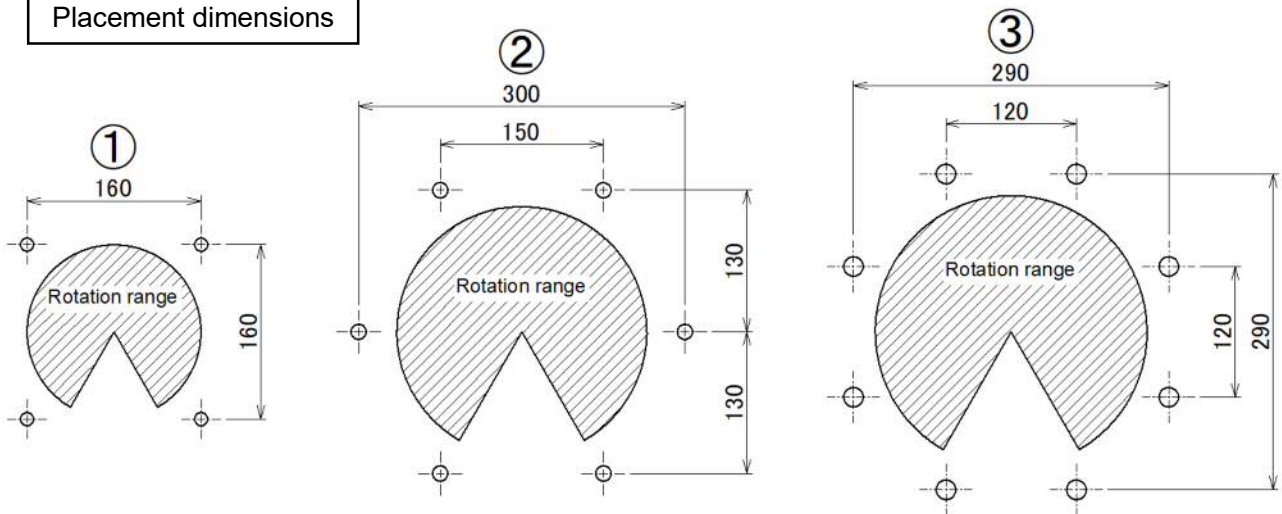



When installing the product on a dolly or a mount frame, use bolts of strength class 10.9 or 12.9 and ensure a screw-in depth of 1.5D or more.



- When installing the product, make sure that the installation surface is leveled correctly. If the surface is not leveled, the arm may not be held in position due to inclination of the tip of the arm or swing of the arm when the rotation lock is not used.

3.4.2 Movement and installation of multi-axis product

- 
 - The multi-axis product shall be moved and installed by a service person with a crane (if the service person does not have the crane license, a qualified, skilled person shall crane the product in the presence of the service person under the person’s direction).
- 
 - The crane shall be operated by qualified experts wearing protective equipment such as helmets and safety shoes and the lifting height shall be the minimum necessary.
 - Use wire ropes or belt slings having sufficient safety load for the weight of the multi-axis product.
 - When moving and installing the product, hoist or lift in a well-balanced state (at first, hoist or lift it slightly and make sure that it is well-balanced before transporting).
- 
 - Do not transport the product by any other method other than the above one method. It is prohibited to manually transport.

1. The product is provided with four eyebolts for hoisting before shipment. Use a lifting beam having a sufficient safety load for the weight of the multi-axis product, and hoist it in a well-balanced state to keep the wire ropes or belt slings vertical.

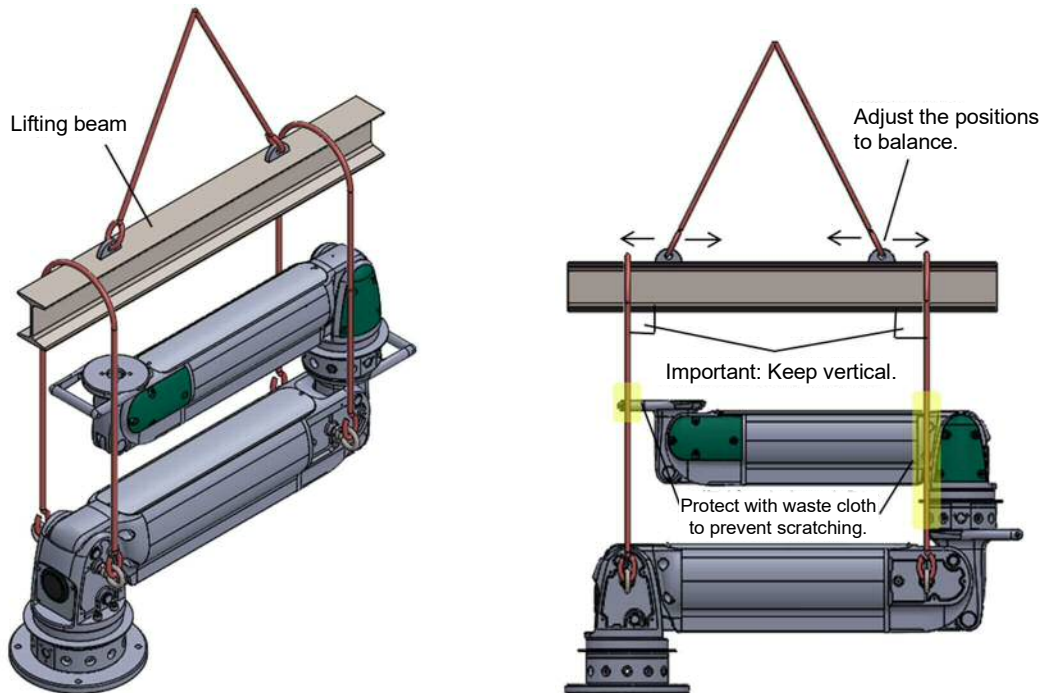

2. Fit the base plate to the anchor reinforcing bars operating the crane and tighten the nuts evenly. When installing the product on a mount or a dolly, tighten bolts of strength class 10.9 or 12.9 evenly.

Product model number	Anchor bar dimensions	Tightening torque
PAW-S-8 PAW-M-8S PAW-S-X PAW-M-8X	W3/8" or M10	25N·m±10%
PAW-S-Z PAW-M-XS PAW-M-XZ PAW-M-8XS PAW-M-8XZ	W1/2" or M12	43N·m±10%
PAW-M-ZS PAW-M-XZS	W5/8" or M16	106N·m±10%

3. After making sure that the product is firmly secured, remove the wire ropes or belt slings.

4. (a) Power Arm unit

- Remove the eyebolts and nuts from the Power Arm unit, and fit the supplied covers.
(Tightening torque: $1.2\text{N}\cdot\text{m}\pm 10\%$)

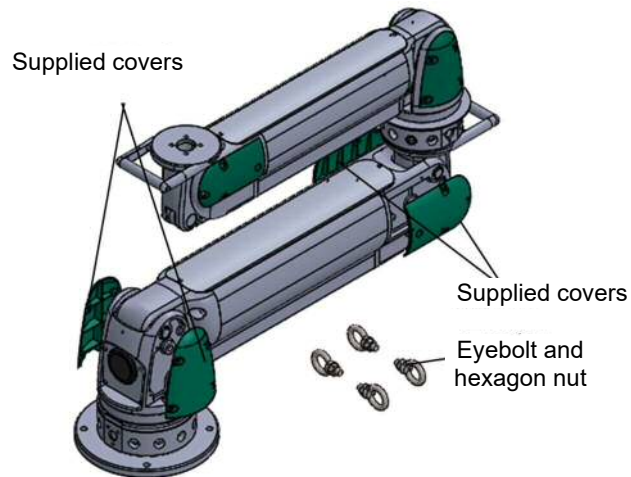

- Discard the removed eyebolts and nuts. They must not be reused.

(b) SCARA arm unit

- Remove the eyebolt blocks from the lowermost rotation unit.

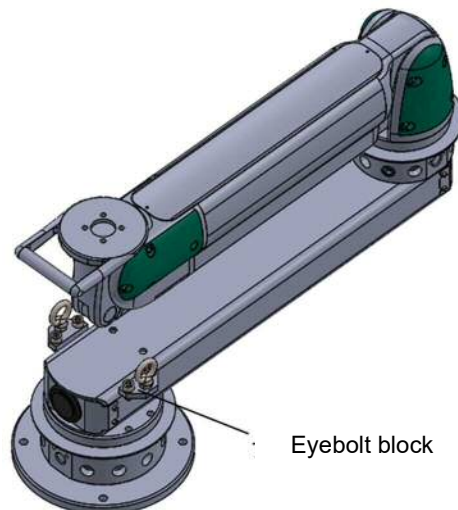

- The removed eyebolt blocks and bolts will be used for relocation. Keep them for later use.

5. After installation, remove the stopper bolt of the rotating unit once and insert it according to the layout position.
See page 31 for the hex wrench and stopper bolt to be used.

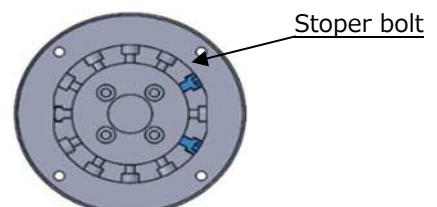

3.5 Relocation of multi-axis product in use

When relocating the multi-axis product in use (including the finished product after assembly of the units), observe the following procedure.

1. Move the movement range controlling stopper bolts of all rotation units to the following positions to prevent rotation of all arms.

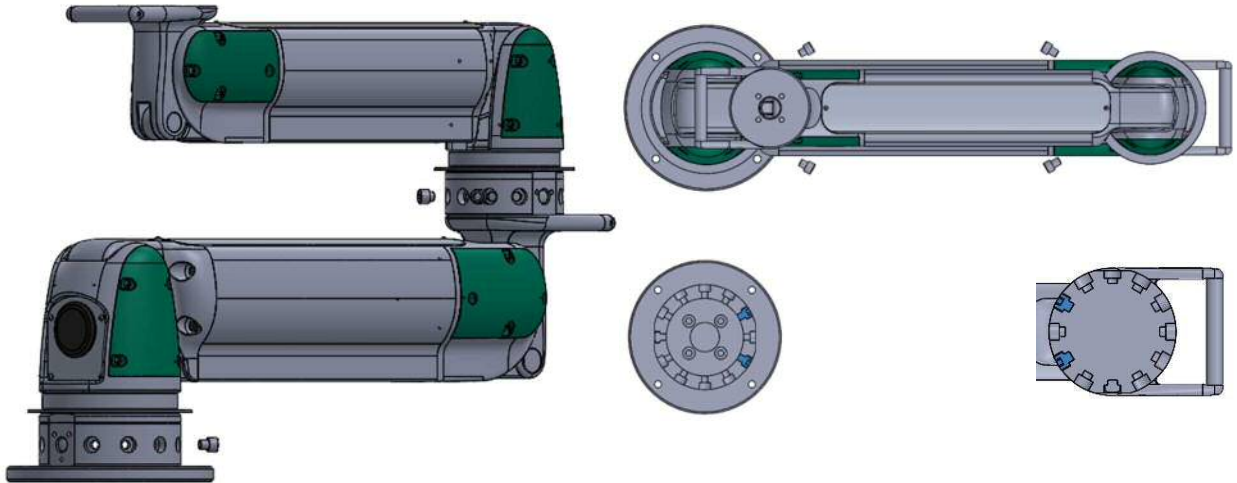

2. Move all arms to the lower end, and stop air supplied to the equipment.

When the product is electrically controlled, shut off the power supply to the electric system.



- Be sure to shut off the power supply to the electric system. If the electric wiring is disconnected without shutting off the power supply, electric shock may be caused.

3. Remove the upper covers of the Power Arm unit.

4. Loosen the bleed bolts marked in yellow two or three turns to discharge the residual pressure in the cylinder.

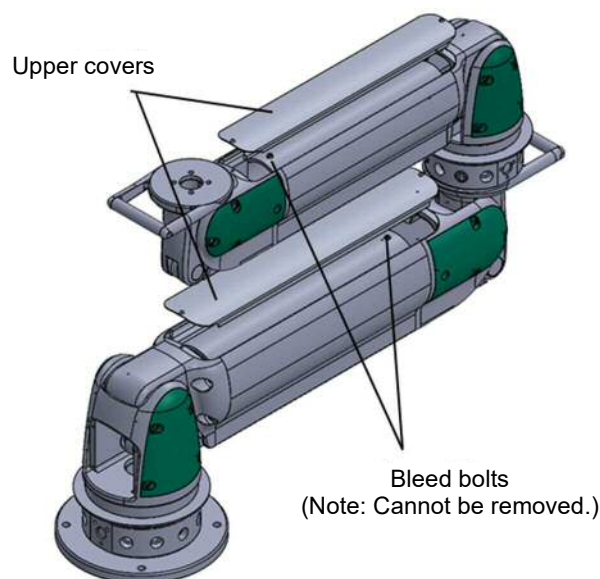

- The bleed bolts cannot be removed. If bleed bolts are forcibly removed, they may be damaged. Do not remove them.

5. If there are any jigs or attachments on the tip of the arm, remove all of them to handle only the product.
6. (a) Power Arm unit

Remove the covers from the Power Arm unit, fit new eyebolts and hexagon nuts (type 1) vertically as shown in the following figure, and tighten the hexagon nuts.

* Use eyebolts and hexagon nuts (type 1) (made of steel) conforming to the standards (ISO/IEC, JIS, etc.) in the user's country and region.

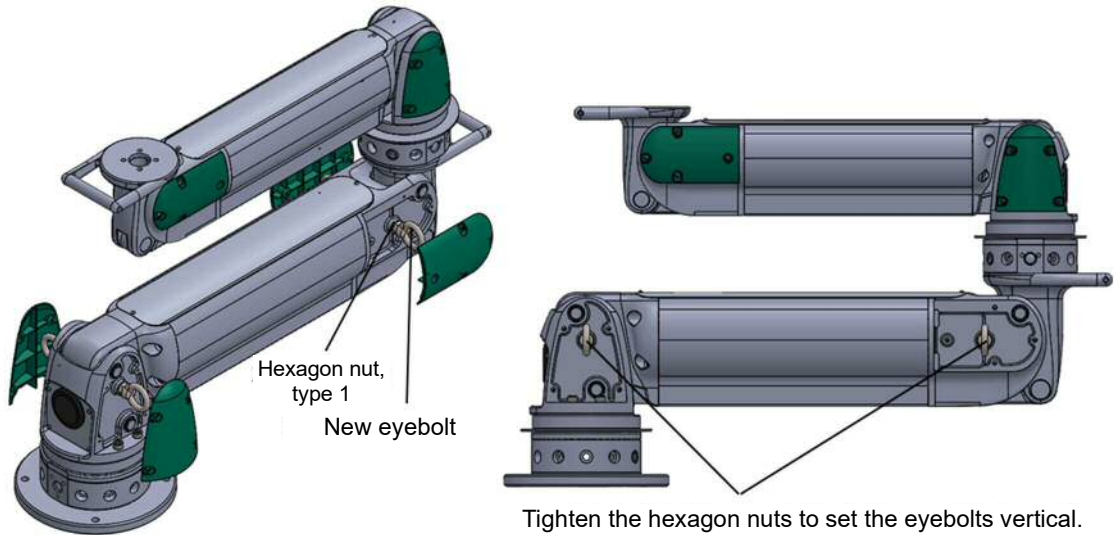

- (b) SCARA arm unit

Fit the eyebolt blocks to the lowermost rotation unit with bolts.

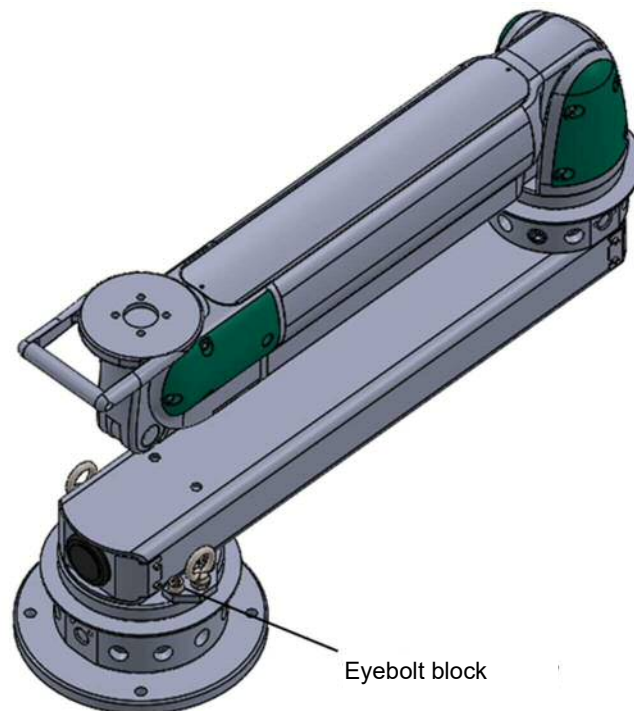

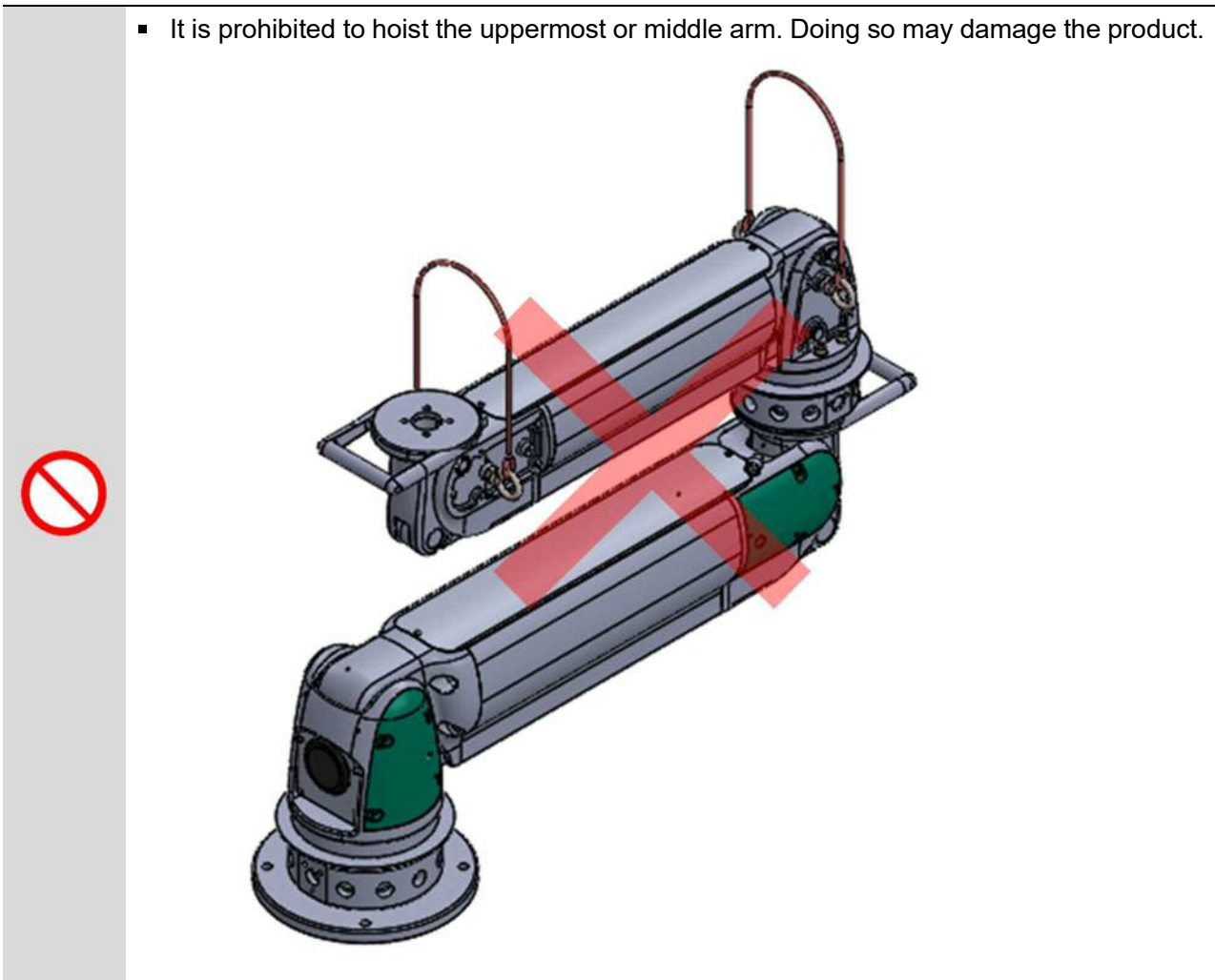

7. Move and install in the same manner as stated in 3.4.2.

- It is prohibited to hoist the uppermost or middle arm. Doing so may damage the product.



4. Usage

4.1 Safety Instructions

- 
 - Rubber cushions and shock absorber are built in at the upper, lower and rotation ends. However, the rubber cushions are designed only for rotation angular control and cannot absorb severe shock.
 - Do not use the arm in such a way that it collides against the upper, lower or rotation end.
- 
 - If the arm is left at the lower end with no pressure in the cylinder chamber, the internal cushion rubber may adhere. When applying pressure after leaving, gradually apply pressure while lifting up the operation handle to separate the adhering rubber.

4.2 Rotation Range

- 
 - The adjustment of the rotation range must be performed by a repair person.
 - The contents of 4.2.1 and 4.2.2 are applied from serial No.230928 (from Sep.28.2023). However, PAW-RU-ZS does not have maintenance holes because it keeps the mechanism of SM-A13989/4.

4.2.1 Restricting the rotation range (From SM-A13989/5)

The rotation range of each rotation unit can be restricted by screwing the stopper bolts into the adjustment holes.

Inside of Rotary unit has stopper plate at product label position. Put stopper bolts into adjustment holes of intended angular range. However, stopper bolts can not put into adjustment holes at 30 degrees position from rotation end (300 degree pos.).

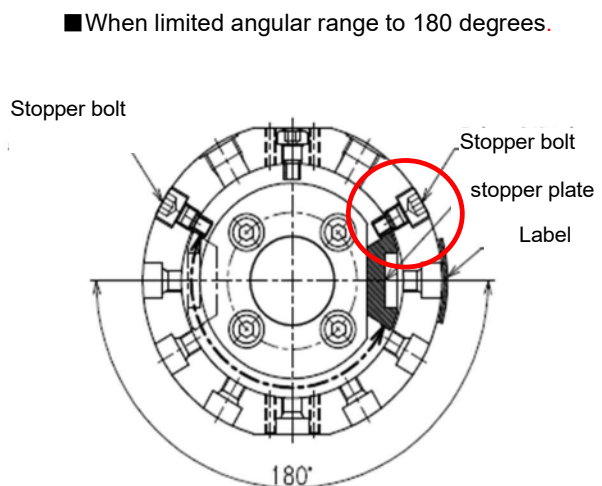
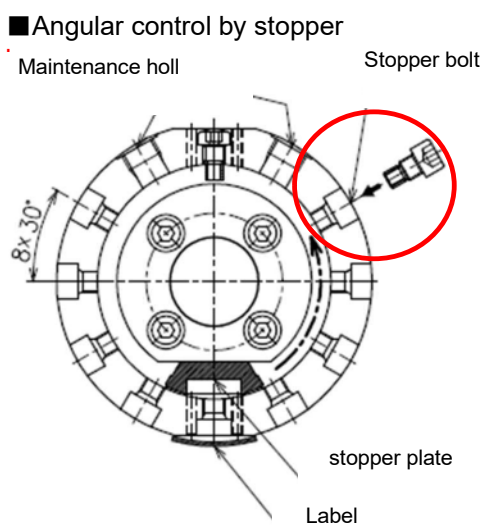

Point When a multi-axis (particularly 3 axes or more) model is used, it is recommended that the rotation ranges of the rotation parts other than the lowermost one are less than 180° (the axis motion can be easily controlled).

■ When rotating 300 degrees

Do not insert the stopper bolt

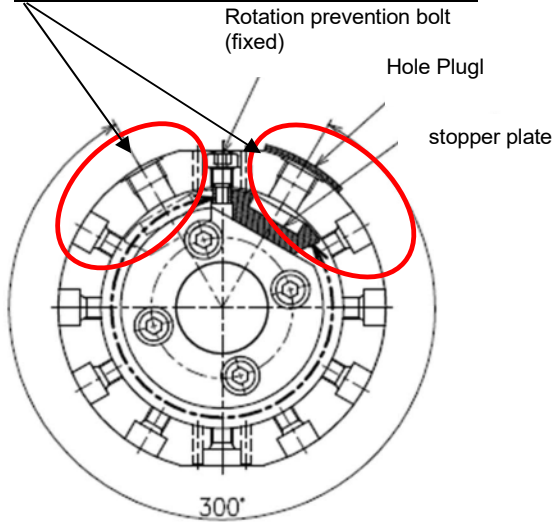

■ Cautions for stopper bolts

Stopper bolt cannot be inserted

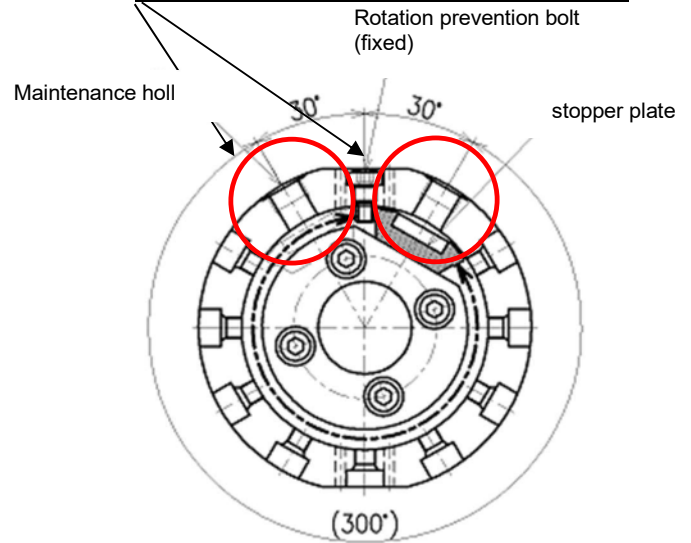

【Stopper Bolts】

- The thread size of the stopper bolt and width of the hexagonal hole are as follows.
Use a compatible hexagonal wrench.
- When installing or removing the stopper bolt, pay attention to the overall length of the stopper bolt before reassembling. Inserting a stopper bolt of a different size with a different overall length will result in failure of normal rotation operation.

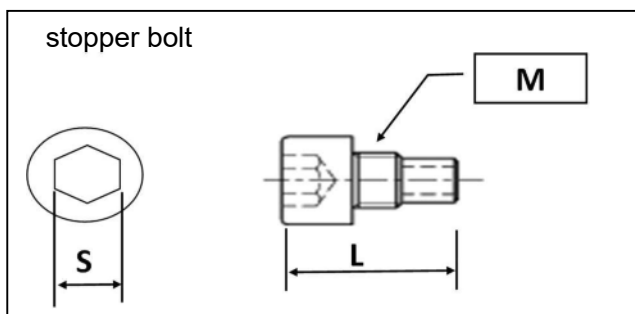
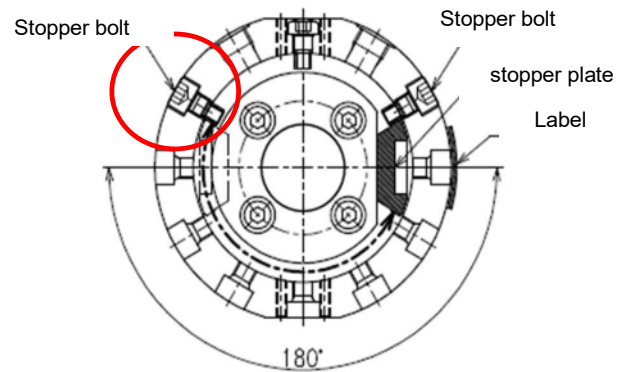
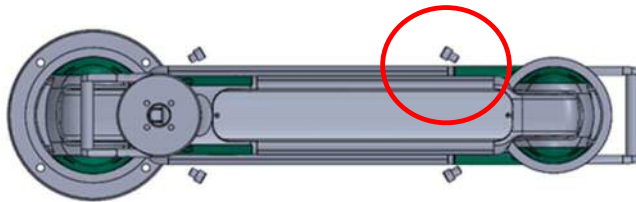

Rotation unit	thread size of the stopper bolt M	overall length of the stopper bolt L (mm)	width of the hexagonal hole S (mm)
PAW-RU-T	M10	25	8
PAW-RU-8	M12	28	10
PAW-RU-X	M12	32	10
PAW-RU-Z	M16 (Note)	43	14 (Note)
PAW-RU-ZS	M16	46	14

Note) The stopper bolt of PAW-RU-Z has been changed from SM-A13989/5 to M16.

4.2.2 Maintenance hole on rotating unit (From SM-A13989-A/5)

Each rotary unit has a maintenance hole in case the stopper bolt should break.

If a broken piece of the stopper bolt remains inside the rotary unit, remove it from the maintenance hole.

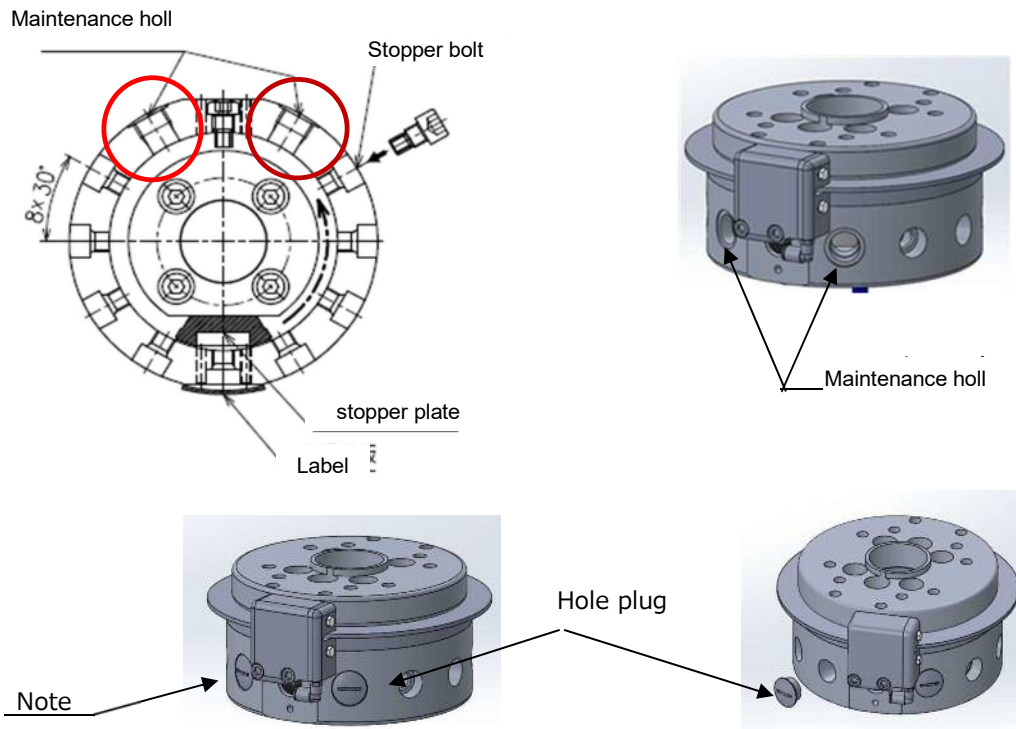

Note) When removing the hole plug (one side) of PAW-RU-T/RU-8, lock unit must be removed, See [Rotation lock unit] on page 57

Currently, PAW-RU-ZS does not have maintenance holes because it keeps the mechanism of SM-A13989/4.

4.3 Manually Unlocking Method



- The manual unlocking operation must be performed by a repair person who has sufficient knowledge of machines and air circuits.
- Remove the transfer object or workpiece at the tip before unlocking as much as possible.

When a trouble occurs (in the state where air is not supplied), the arm can be manually unlocked.

4.3.1 In the vertical direction

1. Stop the supply of air to the system and equipment (close the shut-off valve and discharge the residual pressure).
When the arm is electrically controlled, shut off the power supply to the electric system.
2. Remove the upper cover of the Power Arm unit.
3. Loosen the bleed bolt marked in yellow on the upper surface two or three turns.

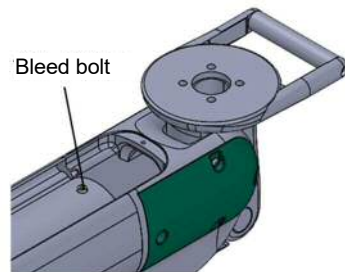

- The bleed bolts cannot be removed. If they are forcibly removed, they may be damaged. Do not remove them.

4. The air in the air cylinder will be gradually discharged and the arm will slowly move down under its own weight.



- The arm will slowly move down for safety. It cannot be lowered rapidly.

5. After the air in the air cylinder is completely discharged, tighten the bleed bolt.
(Tightening torque: $1.3\text{N}\cdot\text{m}\pm 10\%$)



- If the bleed bolt is excessively tightened, it may be damaged. Tighten it to the specified tightening torque.

6. Attach the upper cover.

4.3.2 Rotation direction in the case of model with rotation lock (option: L)

1. Stop the supply of air to the system and equipment (close the shut-off valve and discharge the residual pressure).
When the arm is electrically controlled, shut off the power supply to the electric system.
2. Remove the two plugs (FPL-M5) and screw two hexagon socket head cap screws into the threaded holes without the plugs to unlock the rotation direction.

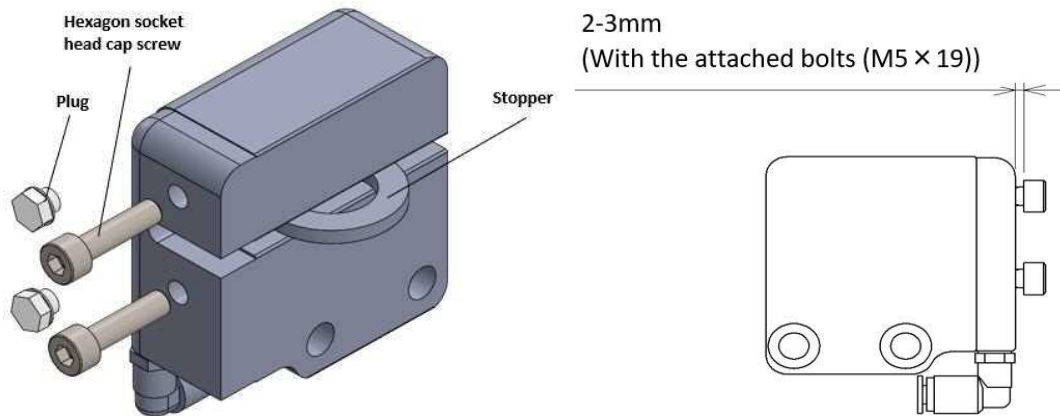

- Do not use tools such as a hex key.
- Do not turn the screws too tightly. The rotation lock unit will be damaged.
- Do not screw until less than 2-3mm.



- For the hexagon socket head cap screw for manual release, use the hexagon socket head cap screw M5 x 20 with strength class 10.9 to 12.9.
(If M5x20 is used, the remaining amount of screws shown in the above figure will be 3 to 4 mm.)

3. After completing the work in the manually released state, loosen and remove the two hexagon socket head cap screws that have been screwed in all the way.
4. Screw the two plugs (FPL-M5) into the threaded holes and tighten them.
(Tightening torque: $1.3\text{N}\cdot\text{m} \pm 10\%$)

5. Assembly of unit product

-  The assembly of units must be performed by a repair person who has sufficient knowledge of machine assembly and pneumatic equipment assembly.

Some of the Power Arm units, rotation units, SCARA arm unit and base plate are heavy. When installing the heavy unit, hoist the unit with a crane and install it.

-  The crane shall be operated by experts wearing protective equipment such as helmets and safety shoes and the lifting height shall be the minimum necessary.
- Use wire ropes or belt slings having sufficient safety load for the weight of the multi-axis product.
- When moving and installing the product, hoist or lift in a well-balanced state (at first, hoist or lift it slightly and make sure that it is well-balanced before transporting).

The Power Arm unit is shipped with four eyebolts for hoisting. Other units are not included with hoisting attachment. Prepare the required members listed in the table below before installation if necessary.

Unit name	Required parts
Rotation unit PAW-RU-ZS	M16 eyebolt: 2 pcs. M16 hexagon nut (type 1): 2 pcs.
SCARA arm unit PAW-SU-XS	M10 eyebolt: 1 pc. M12 eyebolt: 1 pc. M10 hexagon nut (type 1): 1 pc. M12 hexagon nut (type 1): 1 pc.
SCARA arm unit PAW-SU-ZS	M12 eyebolt: 1 pc. M16 eyebolt: 1 pc. M12 hexagon nut (type 1): 1 pc. M16 hexagon nut (type 1): 1 pc.
Base plate PAW-BP-ZS	M14 eyebolt: 2 pcs. M14 hexagon nut (type 1): 2 pcs.

* Use eyebolts and hexagon nuts (type 1) (made of steel) conforming to the standards (ISO/IEC, JIS, etc.) in the user's country and region.

Hoisting method

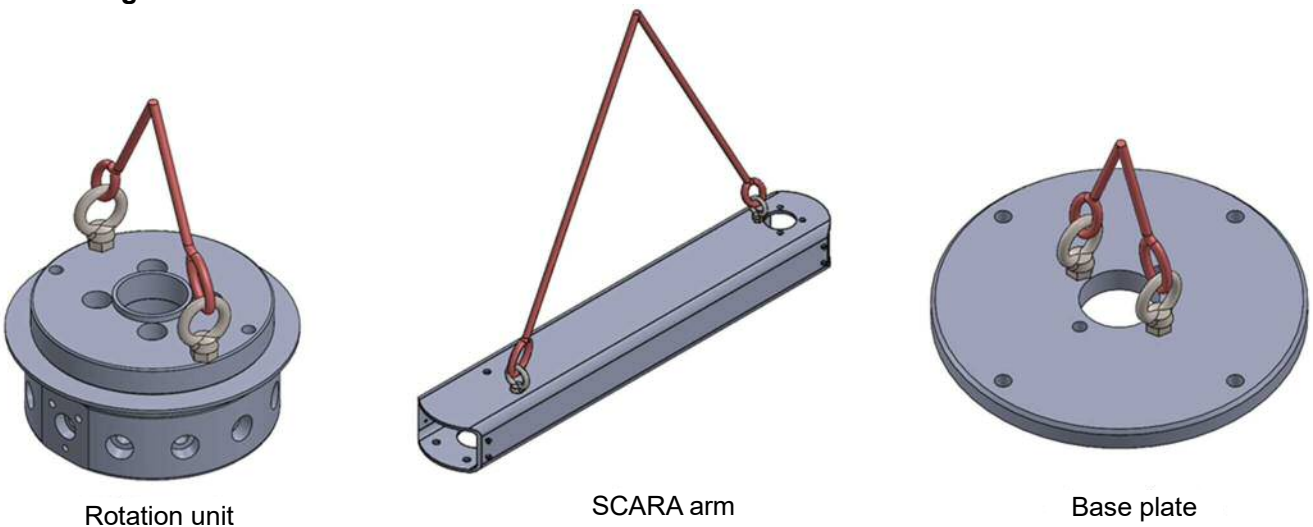

Units not shown above weigh 15 kg or less and do not need hoisting attachments. Handle the units taking great care not to drop them or pinch your fingers.

Required pneumatic equipment

Pneumatic equipment will be required in the assembly process. Prepare one changeover valve (miniature mechanical selector valve MS-01-SE1 or the like) that can be kept in a state and the same number of precision regulators RP2000 as the number of the Power Arm units.

When tightening each part, use a torque wrench and tighten the part to the specified tightening torque.



- Tighten them with the specified tightening torque. Tightening with a torque other than the specified tightening torque may cause the bolts to loosen during use, resulting in malfunction.

Adhesive to apply to bolts

If it is instructed to apply adhesive to the bolts, refer to the figure below and apply a small amount. Wipe off extra adhesive.

Recommended adhesive: Medium strength type, Loctite 243 (Henkel)
Scotch-Weld TL43J (3M)

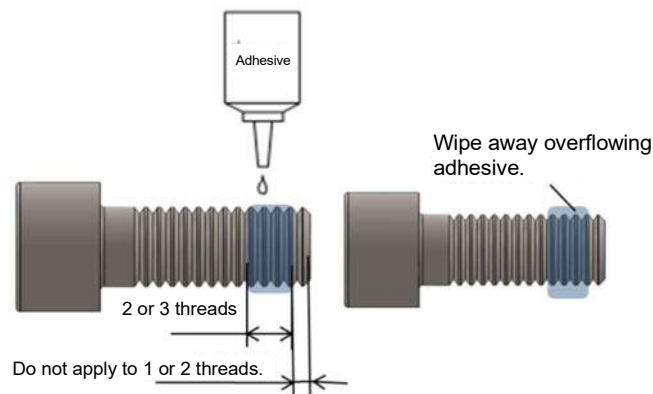

- Pay attention to the amount of adhesive applied. Applying a large amount of adhesive, extra adhesive may enter the inside and cause malfunction.

5.1 Preparation

5.1.1 Required members

Common required members

- Spiral tube: Polyethylene, OD 10 to 12
Recommended product: TS-9(HellermannTyton)
or WPE25 (HellermannTyton, Between Power arm and the controller)
- Binding band: Appropriate quantity
Recommended product: AB100 (Hellermann Tyton)
- In the case of model with rotation lock (option: L): 0.2mm(or 0.15mm) shim x 2 pcs.
(To be used for positioning during assembly of the rotation lock unit)

5.1.2 Required parts

Prepare parts appropriate to the model number (combination of axes) and cut the tube to the specified length (tolerances $^{+5}_0$).



- Cut the tube at right angles with the dedicated cutter.

Dedicated cutter: AZ-1200 (Aoi Co., Ltd.)

Required parts for PAW-S-8

Common and individual required parts	Name	Length, quantity	Remarks
Common required parts	Wear-resistant tube ARU-8 x 5 (Aoi Co., Ltd.)	2876 mm	
	Soft nylon tube F-1504 (CKD Corporation)	2614 mm	
Individual required parts (PAW-S-8, PAW-S-8-R)	Fitting blank plug GWP4-B	2 pcs.	For PAW-S-8, PAW-S-8-R, they are required in addition to the common parts
Individual required parts (PAW-S-8-L)	Soft nylon tube F-1504 (CKD Corporation)	553 mm	For PAW-S-8-L, it is required in addition to the common parts
	Fitting blank plug GWP4-B	1 pc.	
Individual required parts (PAW-S-8-LR)	Soft nylon tube F-1504 (CKD Corporation)	553 mm	For PAW-S-8-LR, it is required in addition to the common parts
	Soft nylon tube F-1504 (CKD Corporation)	538 mm	

Required parts for PAW-S-X

Common and individual required parts	Name	Length, quantity	Remarks
Common required parts	Wear-resistant tube ARU-8 x 5 (Aoi Co., Ltd.)	2985 mm	
	Soft nylon tube F-1504 (CKD Corporation)	2693 mm	
Individual required parts (PAW-S-8, PAW-S-X-R)	Fitting blank plug GWP4-B	2 pcs.	For PAW-S-X, PAW-S-X-R, they are required in addition to the common parts
Individual required parts (PAW-S-X-L)	Soft nylon tube F-1504 (CKD Corporation)	653 mm	For PAW-S-X-L, it is required in addition to the common parts
	Fitting blank plug GWP4-B	1 pc.	
Individual required parts (PAW-S-X-LR)	Soft nylon tube F-1504 (CKD Corporation)	653 mm	For PAW-S-X-LR, it is required in addition to the common parts
	Soft nylon tube F-1504 (CKD Corporation)	628 mm	

Required parts for PAW-S-Z

Common and individual required parts	Name	Length, quantity	Remarks
Common required parts	Wear-resistant tube ARU-10 x 6.5 (Aoi Co., Ltd.)	3076 mm	
	Soft nylon tube F-1504 (CKD Corporation)	2746 mm	
Individual required parts (PAW-S-Z, PAW-S-Z-R)	Fitting blank plug GWP4-B	2 pcs.	For PAW-S-Z, PAW-S-Z-R, they are required in addition to the common parts
Individual required parts (PAW-S-Z-L)	Soft nylon tube F-1504 (CKD Corporation)	797 mm	For PAW-S-Z-L, it is required in addition to the common parts
	Fitting blank plug GWP4-B	1 pc.	
Individual required parts (PAW-S-Z-LR)	Soft nylon tube F-1504 (CKD Corporation)	797 mm	For PAW-S-Z-LR, it is required in addition to the common parts
	Soft nylon tube F-1504 (CKD Corporation)	732 mm	

■ Required parts for PAW-M-8S

Common and individual required parts	Name	Length, quantity	Remarks
Common required parts	Wear-resistant tube ARU-8 x 5 (Aoi Co., Ltd.)	3698 mm	
	Fitting Y-shaped tee GWY44-0	1 pc.	
	Soft nylon tube F-1504 (CKD Corporation)	2746 mm	
	Soft nylon tube F-1504 (CKD Corporation)	688 mm	
Individual required parts (PAW-M-8S, PAW-M-8S-R)	Fitting blank plug GWP4-B	3 pcs.	For PAW-M-8S, PAW-M-8S-R, they are required in addition to the common parts
Individual required parts (PAW-M-8S-L)	Soft nylon tube F-1504 (CKD Corporation)	653 mm	For PAW-M-8S-L, it is required in addition to the common parts
	Soft nylon tube F-1504 (CKD Corporation)	553 mm	
	Fitting blank plug GWP4-B	1 pc.	
Individual required parts (PAW-M-8S-LR)	Soft nylon tube F-1504 (CKD Corporation)	653 mm	For PAW-M-8S-LR, it is required in addition to the common parts
	Soft nylon tube F-1504 (CKD Corporation)	553 mm	
	Soft nylon tube F-1504 (CKD Corporation)	538 mm	

■ Required parts for PAW-M-XS

Common and individual required parts	Name	Length, quantity	Remarks
Common required parts	Wear-resistant tube ARU-10 x 6.5 (Aoi Co., Ltd.)	3940 mm	
	Fitting Y-shaped tee GWY44-0	1 pc.	
	Soft nylon tube F-1504 (CKD Corporation)	2877 mm	
	Soft nylon tube F-1504 (CKD Corporation)	790 mm	
Individual required parts (PAW-M-XS, PAW-M-XS-R)	Fitting blank plug GWP4-B	3 pcs.	For PAW-M-XS, PAW-M-XS-R, they are required in addition to the common parts
Individual required parts (PAW-M-XS-L)	Soft nylon tube F-1504 (CKD Corporation)	797 mm	For PAW-M-XS-L, it is required in addition to the common parts
	Soft nylon tube F-1504 (CKD Corporation)	653 mm	
	Fitting blank plug GWP4-B	1 pc.	
Individual required parts (PAW-M-XS-LR)	Soft nylon tube F-1504 (CKD Corporation)	797 mm	For PAW-M-XS-LR, it is required in addition to the common parts
	Soft nylon tube F-1504 (CKD Corporation)	653 mm	
	Soft nylon tube F-1504 (CKD Corporation)	628 mm	

■ Required parts for PAW-M-ZS

Common and individual required parts	Name	Length, quantity	Remarks
Common required parts	Wear-resistant tube ARU-10 x 6.5 (Aoi Co., Ltd.)	4258 mm	
	Fitting Y-shaped tee GWY44-0	1 pc.	
	Soft nylon tube F-1504 (CKD Corporation)	3013 mm	
	Soft nylon tube F-1504 (CKD Corporation)	970 mm	
Individual required parts (PAW-M-ZS, PAW-M-ZS-R)	Fitting blank plug GWP4-B	3 pcs.	For PAW-M-ZS, PAW-M-ZS-R, they are required in addition to the common parts
Individual required parts (PAW-M-ZS-L)	Soft nylon tube F-1504 (CKD Corporation)	900 mm	For PAW-M-ZS-L, it is required in addition to the common parts
	Soft nylon tube F-1504 (CKD Corporation)	797 mm	
	Fitting blank plug GWP4-B	1 pc.	
Individual required parts (PAW-M-ZS-LR)	Soft nylon tube F-1504 (CKD Corporation)	900 mm	For PAW-M-ZS-LR, it is required in addition to the common parts
	Soft nylon tube F-1504 (CKD Corporation)	797 mm	
	Soft nylon tube F-1504 (CKD Corporation)	732 mm	

■ Required parts for PAW-M-8X

Common and individual required parts	Name	Length, quantity	Remarks
Common required parts	Wear-resistant tube ARU-8 x 5 (Aoi Co., Ltd.)	3864 mm	
	Wear-resistant tube ARU-10 x 6.5 (Aoi Co., Ltd.)	2985 mm	
	Soft nylon tube F-1504 (CKD Corporation)	2693 mm	
	Soft nylon tube F-1504 (CKD Corporation)	950 mm	
Individual required parts (PAW-M-8X, PAW-M-8X-R)	Fitting blank plug GWP4-B	3 pcs.	For PAW-M-8X, PAW-M-8X-R, they are required in addition to the common parts
Individual required parts (PAW-M-8X-L)	Soft nylon tube F-1504 (CKD Corporation)	653 mm	For PAW-M-8X-L, it is required in addition to the common parts
	Soft nylon tube F-1504 (CKD Corporation)	553 mm	
	Fitting blank plug GWP4-B	1 pc.	
Individual required parts (PAW-M-8X-LR)	Soft nylon tube F-1504 (CKD Corporation)	653 mm	For PAW-M-8X-LR, it is required in addition to the common parts
	Soft nylon tube F-1504 (CKD Corporation)	553 mm	
	Soft nylon tube F-1504 (CKD Corporation)	538 mm	

■ Required parts for PAW-M-XZ

Common and individual required parts	Name	Length, quantity	Remarks
Common required parts	Wear-resistant tube ARU-10 x 6.5 (Aoi Co., Ltd.)	4200 mm	
	Wear-resistant tube ARU-10 x 6.5 (Aoi Co., Ltd.)	3076 mm	
	Soft nylon tube F-1504 (CKD Corporation)	2746 mm	
	Soft nylon tube F-1504 (CKD Corporation)	1150 mm	
Individual required parts (PAW-M-XZ, PAW-M-XZ-R)	Fitting blank plug GWP4-B	3 pcs.	For PAW-M-XZ, PAW-M-XZ-R, they are required in addition to the common parts
Individual required parts (PAW-M-XZ-L)	Soft nylon tube F-1504 (CKD Corporation)	797 mm	For PAW-M-XZ-L, it is required in addition to the common parts
	Soft nylon tube F-1504 (CKD Corporation)	653 mm	
	Fitting blank plug GWP4-B	1 pc.	
Individual required parts (PAW-M-XZ-LR)	Soft nylon tube F-1504 (CKD Corporation)	797 mm	For PAW-M-XZ-LR, it is required in addition to the common parts
	Soft nylon tube F-1504 (CKD Corporation)	653 mm	
	Soft nylon tube F-1504 (CKD Corporation)	628 mm	

■ Required parts for PAW-M-8XS

Common and individual required parts	Name	Length, quantity	Remarks
Common required parts	Wear-resistant tube ARU-8 x 5 (Aoi Co., Ltd.)	4925 mm	
	Wear-resistant tube ARU-10 x 6.5 (Aoi Co., Ltd.)	3940 mm	
	Fitting Y-shaped tee GWY44-0	1 pc.	
	Soft nylon tube F-1504 (CKD Corporation)	2877 mm	
	Soft nylon tube F-1504 (CKD Corporation)	790 mm	
	Soft nylon tube F-1504 (CKD Corporation)	950 mm	
Individual required parts (PAW-M-8XS, PAW-M-8XS-R)	Fitting blank plug GWP4-B	4 pcs.	For PAW-M-8XS, PAW-M-8XS-R, they are required in addition to the common parts
Individual required parts (PAW-M-8XS-L)	Soft nylon tube F-1504 (CKD Corporation)	797 mm	For PAW-M-8XS-L, it is required in addition to the common parts
	Soft nylon tube F-1504 (CKD Corporation)	653 mm	
	Soft nylon tube F-1504 (CKD Corporation)	553 mm	
	Fitting blank plug GWP4-B	1 pc.	
Individual required parts (PAW-M-8XS-LR)	Soft nylon tube F-1504 (CKD Corporation)	797 mm	For PAW-M-8XS-LR, it is required in addition to the common parts
	Soft nylon tube F-1504 (CKD Corporation)	653 mm	
	Soft nylon tube F-1504 (CKD Corporation)	553 mm	
	Soft nylon tube F-1504 (CKD Corporation)	538 mm	

■ Required parts for PAW-M-XZS

Common and individual required parts	Name	Length, quantity	Remarks
Common required parts	Wear-resistant tube ARU-10 x 6.5 (Aoi Co., Ltd.)	5350 mm	
	Wear-resistant tube ARU-10 x 6.5 (Aoi Co., Ltd.)	4258 mm	
	Fitting Y-shaped tee GWY44-0	1 pc.	
	Soft nylon tube F-1504 (CKD Corporation)	3013 mm	
	Soft nylon tube F-1504 (CKD Corporation)	970 mm	
	Soft nylon tube F-1504 (CKD Corporation)	1150 mm	
Individual required parts (PAW-M-XZS, PAW-M-XZS-R)	Fitting blank plug GWP4-B	4 pcs.	For PAW-M-XZS, PAW-M-XZS-R, they are required in addition to the common parts
Individual required parts (PAW-M-XZS-L)	Soft nylon tube F-1504 (CKD Corporation)	900 mm	For PAW-M-XZS-L, it is required in addition to the common parts
	Soft nylon tube F-1504 (CKD Corporation)	797 mm	
	Soft nylon tube F-1504 (CKD Corporation)	653 mm	
	Fitting blank plug GWP4-B	1 pc.	
Individual required parts (PAW-M-XZS-LR)	Soft nylon tube F-1504 (CKD Corporation)	900 mm	For PAW-M-XZS-LR, it is required in addition to the common parts
	Soft nylon tube F-1504 (CKD Corporation)	797 mm	
	Soft nylon tube F-1504 (CKD Corporation)	653 mm	
	Soft nylon tube F-1504 (CKD Corporation)	628 mm	

■ Required parts for PAW-M-8XZ

Common and individual required parts	Name	Length, quantity	Remarks
Common required parts	Wear-resistant tube ARU-8 x 5 (Aoi Co., Ltd.)	5182 mm	
	Wear-resistant tube ARU-10 x 6.5 (Aoi Co., Ltd.)	4200 mm	
	Wear-resistant tube ARU-10 x 6.5 (Aoi Co., Ltd.)	3076 mm	
	Soft nylon tube F-1504 (CKD Corporation)	2746 mm	
	Soft nylon tube F-1504 (CKD Corporation)	1150 mm	
	Soft nylon tube F-1504 (CKD Corporation)	950 mm	
Individual required parts (PAW-M-8XZ, PAW-M-8XZ-R)	Fitting blank plug GWP4-B	4 pcs.	For PAW-M-8XZ, PAW-M-8XZ-R, they are required in addition to the common parts
Individual required parts (PAW-M-8XZ-L)	Soft nylon tube F-1504 (CKD Corporation)	797 mm	For PAW-M-8XZ-L, it is required in addition to the common parts
	Soft nylon tube F-1504 (CKD Corporation)	653 mm	
	Soft nylon tube F-1504 (CKD Corporation)	553 mm	
	Fitting blank plug GWP4-B	1 pc.	
Individual required parts (PAW-M-8XZ-LR)	Soft nylon tube F-1504 (CKD Corporation)	797 mm	For PAW-M-8XZ-LR, it is required in addition to the common parts
	Soft nylon tube F-1504 (CKD Corporation)	653 mm	
	Soft nylon tube F-1504 (CKD Corporation)	553 mm	
	Soft nylon tube F-1504 (CKD Corporation)	538 mm	

5.2 Base plate

Set the base plate to the anchor reinforcing bars and tighten the nuts evenly.

When installing the product on a mount or a dolly, tighten bolts of strength class 10.9 or 12.9 evenly.

Product model number	Anchor bar dimensions	Tightening torque
PAW-S-8 PAW-S-X PAW-M-8S PAW-M-8X	W3/8" or M10	25N·m±10%
PAW-S-Z PAW-M-XS PAW-M-XZ PAW-M-8XS PAW-M-8XZ	W1/2" or M12	43N·m±10%
PAW-M-ZS PAW-M-XZS	W5/8" or M16	106N·m±10%

- Note that the direction of the base plate in the possible rotation range has been determined on PAW-BP-Z and PAW-BP-ZS.

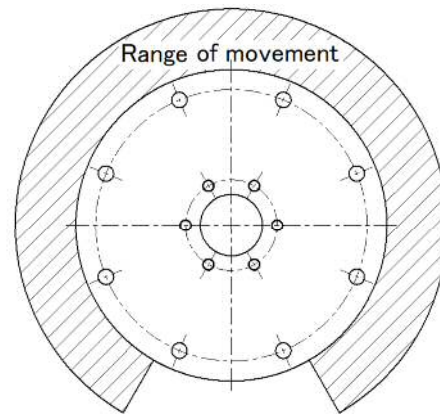
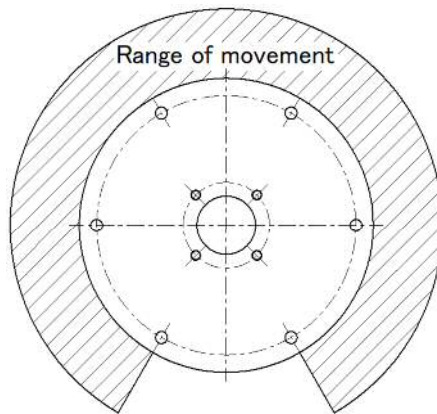

5.3 Rotation unit (lowermost)

1. Place the boss of the rotation unit onto the center hole in the base plate so that they are fitted.
2. Adjust the direction of the rotation unit.

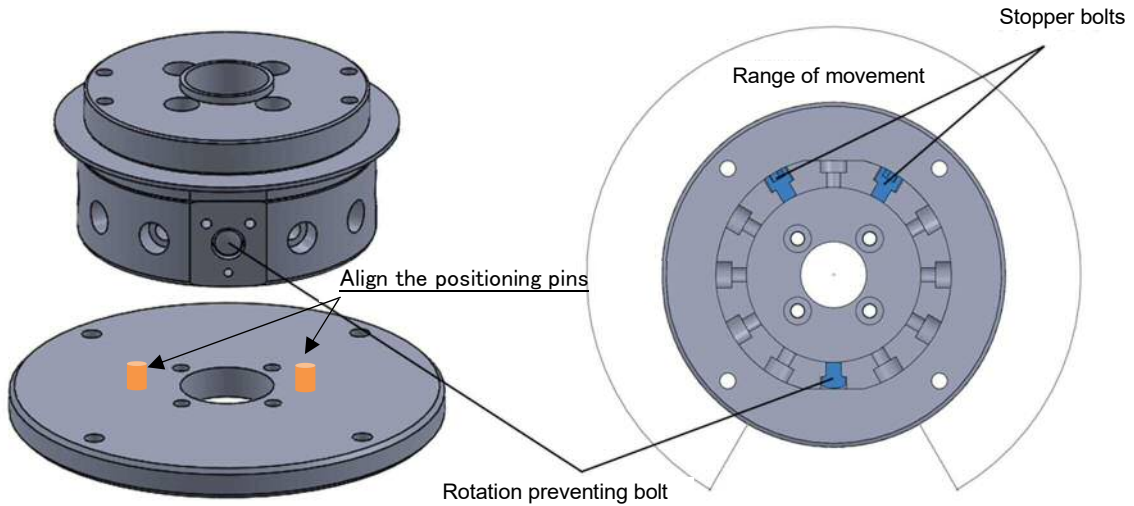

Positioning pin mechanism is applied from serial No.230928 (from Sep.28.2023). (Excluding RU-ZS)

3. Remove the two stopper bolts, turn the mounting plate and tighten the supplied bolts and washers in two positions.

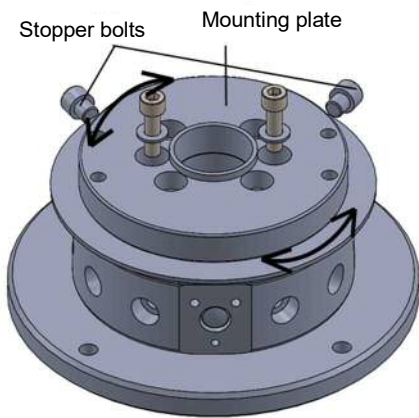

Rotation unit model number	Tightening torque
PAW-RU-8	13N·m±10%
PAW-RU-X	25N·m±10%
PAW-RU-Z	43N·m±10%
PAW-RU-ZS	68N·m±10%

Point

When removing the first stopper bolt, push the mounting plate to the other stopper bolt and the bolt can be removed easily.

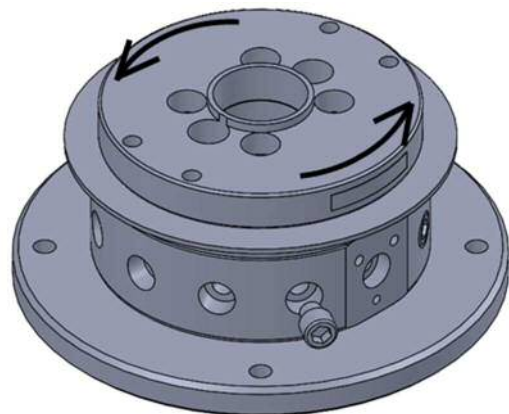

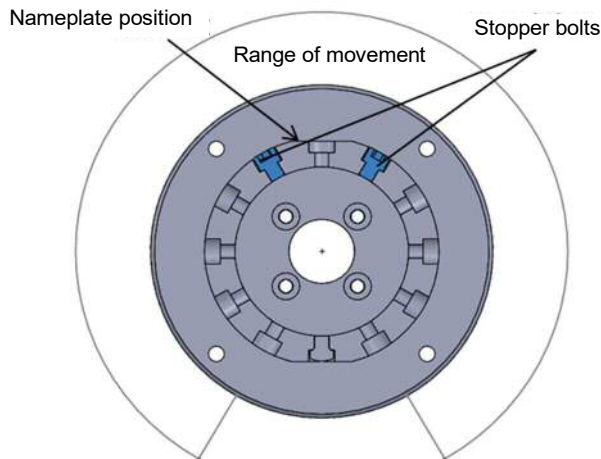

- Assemble the washers without fail.
- Apply adhesive to the bolts.

- Return the mounting plate to the original position (refer to the figure below) using the nameplate as a guide and insert the removed stopper bolts again.

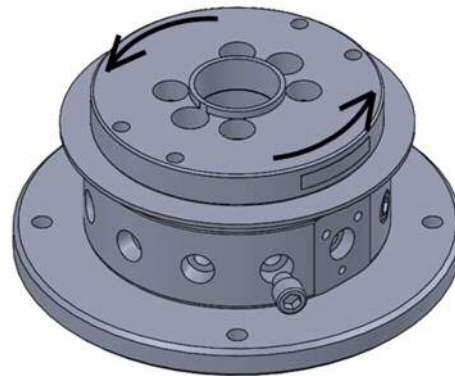

Point
 When inserting the second stopper bolt, push the mounting plate to the other stopper bolt and the bolt can be inserted easily.



 After inserting the stopper bolts, make sure that the mounting plate does not rotate. If it rotates, correct the stopper bolt positions.

[Only in the case of model with rotation lock (option: L)]

- Insert the $\varnothing 4$ tube prepared in “Required parts” in “5.1.2 Preparation” into the hole under the rotation prevention bolt as shown in the figure below and pull it out from the upper surface of the rotation unit.
- When the length of the tube over the upper surface reaches about 50 mm, temporarily secure the tube with masking tape so that it will not come off.

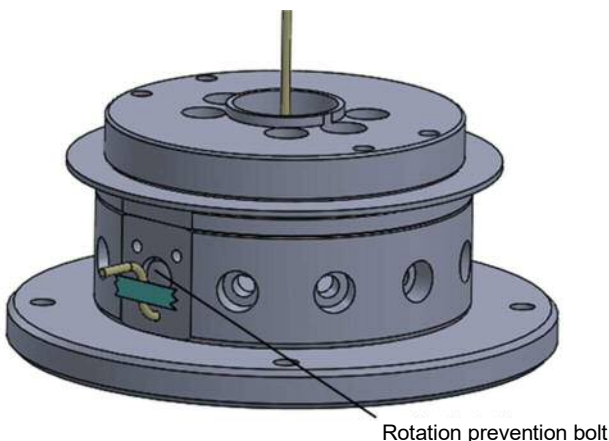

Rotation unit model number	Length of inserted tube
PAW-RU-8	553 mm
PAW-RU-X	653 mm
PAW-RU-Z	797 mm
PAW-RU-ZS	900 mm

5.4 Power Arm unit/ SCARA arm unit (lowermost arm)

1. Remove the upper cover and rear cover of the Power Arm unit or the front cover and rear cover of the SCARA arm unit.

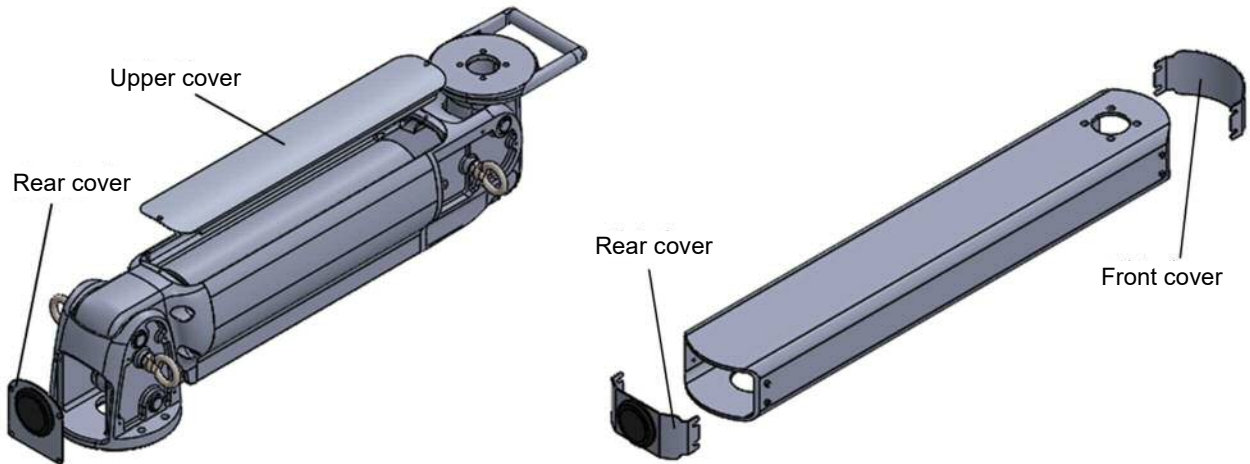

2. Place the Power Arm unit or the SCARA arm unit onto the boss of the rotation unit so that they are fitted.

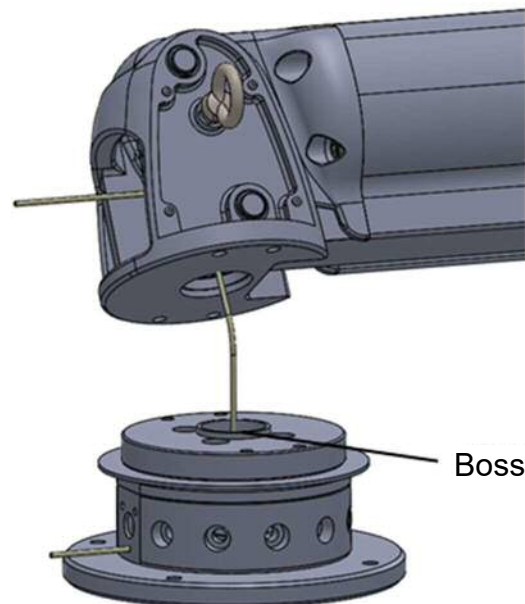

- In the case of model with rotation lock (option: L), insert the $\varnothing 4$ tube pulled out in “In the case of model with rotation lock (option: L)” in “5.3 Rotation unit” into the mounting hole. Be careful not to pinch the tube.

3. Tighten the supplied bolts and washers.

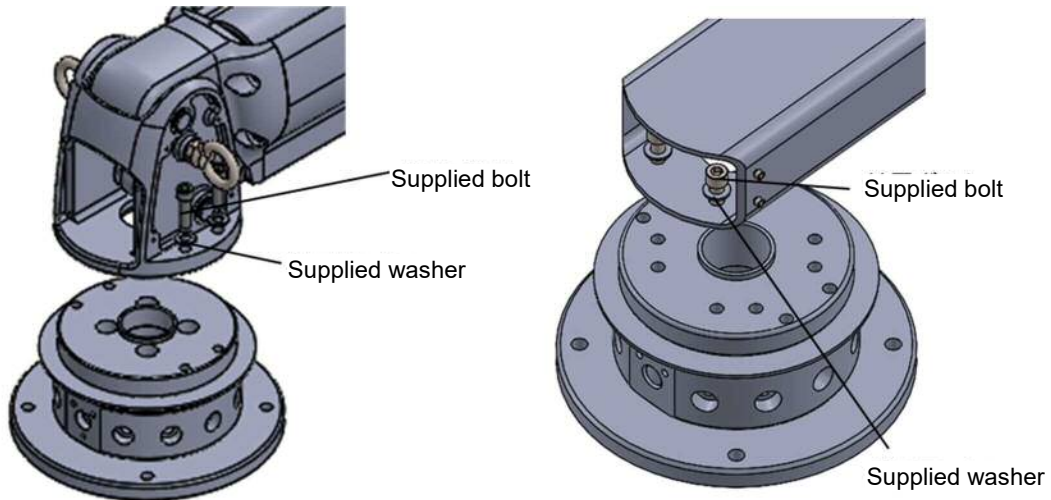

Unit model number	Tightening torque	Supplied bolt
Power Arm unit PAW-AU-8	13N·m±10%	M8 x 35
Power Arm unit PAW-AU-X	25N·m±10%	M10 x 40
Power Arm unit PAW-AU-Z	43N·m±10%	M12 x 45
SCARA arm unit PAW-SU-8S	25N·m±10%	M10 x 35
SCARA arm unit PAW-SU-XS	43N·m±10%	M12 x 40
SCARA arm unit PAW-SU-ZS	106N·m±10%	M16 x 50



- Assemble the washers without fail.
- Apply adhesive to the bolts.

[In the case of Power Arm unit (PAW-AU-[8, X, Z])]

Remove the eyebolts and nuts and fit the supplied covers.

(Tightening torque: 1.3N·m±10%)

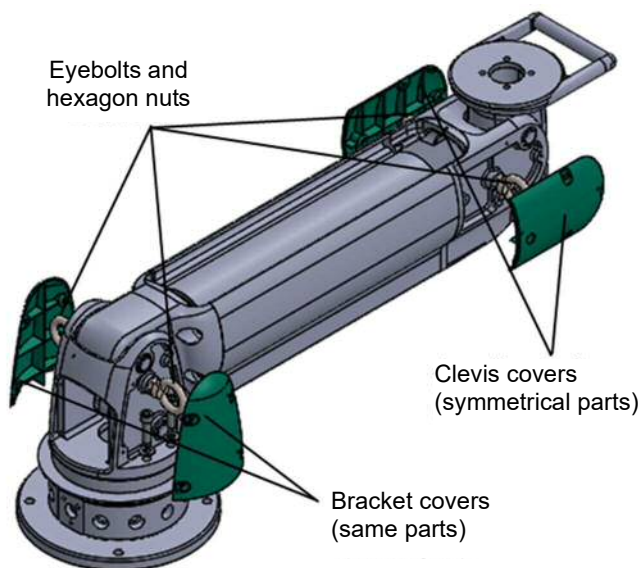

- Discard the removed eyebolts and nuts. They must not be reused.

[In the case of single-axis model (PAW-S-[8, X, Z])]

-> To Step 5.11 (Tubing, page 57)

**[In the case of single-axis model with rotation mechanism at end
(PAW-S-[8, X, Z]-(L)R)]**

-> To Step 5.9 (Rotation unit (rotation mechanism at end), page 51)

[In the case of single-axis model with rotation lock (PAW-S-[8, X, Z]-L)]

-> To Step 5.10 (Installation of rotation lock unit, page 54)

5.5 Rotation unit (the second stage from the bottom)

1. Place the boss of the rotation unit onto the center hole of the Power Arm unit or the SCARA arm unit so that they are fitted.
2. Adjust the direction using the position of the rotation prevention bolt as a guide.

[Number of axes: 2, Bending direction: No symbol]PAW-M-[8S,XS,ZS,8X,XZ]

[Number of axes: 3, Bending direction: C].....PAW-M-[8XS,XZS,8XZ]-C

-> Adjust so that the rotation prevention bolt is on the right side when viewed from the base plate.

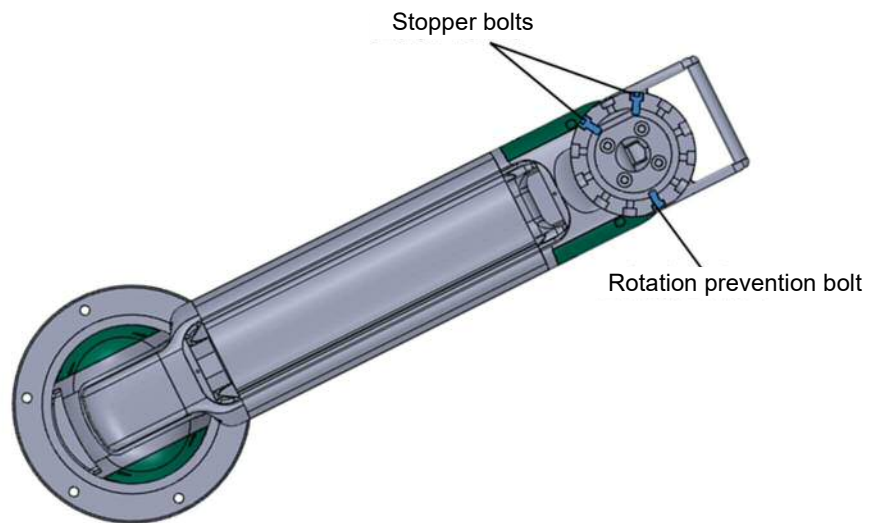

[Number of axes: 2, Bending direction: C].....PAW-M-[8S,XS,ZS,8X,XZ]-C

[Number of axes: 3, Bending direction: No symbol]PAW-M-[8XS,XZS,8XZ]

-> Adjust so that the rotation prevention bolt is on the left side when viewed from the base plate.

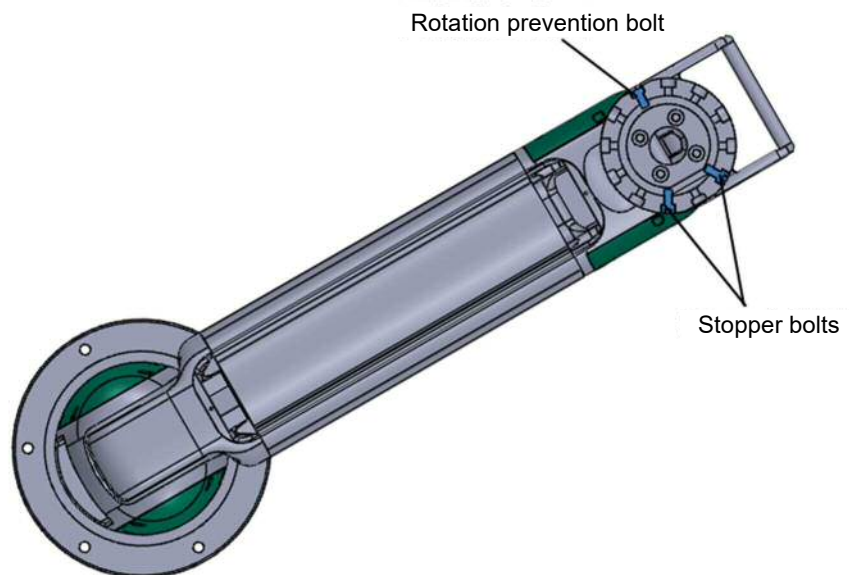

- Remove the stopper bolts, turn the mounting plate and tighten the supplied bolts and washers in the two positions.

(The same work as in 5.3. See page 38.)

Rotation unit model number	Tightening torque
PAW-RU-8	13N·m±10%
PAW-RU-X	25N·m±10%
PAW-RU-Z	43N·m±10%



- Assemble the washers without fail.
- Apply adhesive to the bolts.

- Return the mounting plate to the position shown in the figure below and insert the removed stopper bolts again.

(Similar work to that in 5.3. See page 39.)

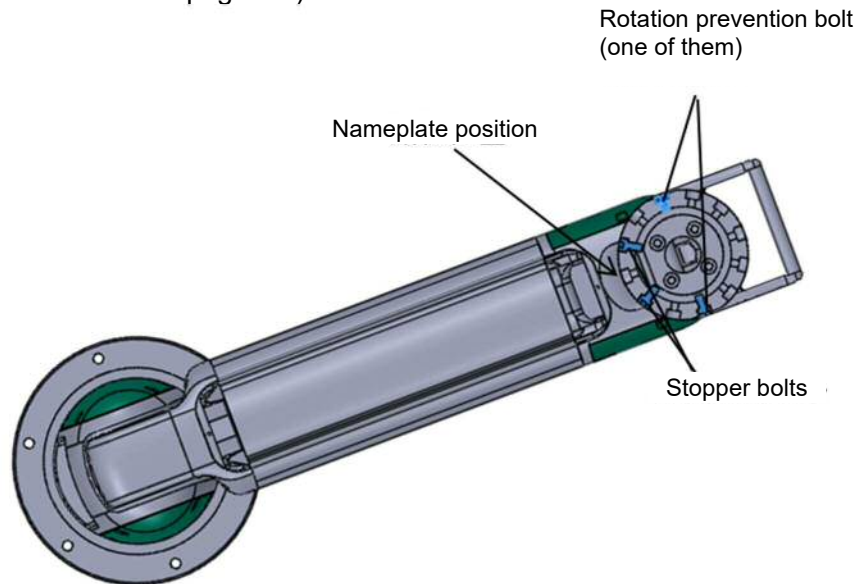

- After inserting the stopper bolts, make sure that the mounting plate does not rotate. If it rotates, correct the stopper bolt positions.

[Only in the case of model with rotation lock (option: L)]

- Insert the ø4 tube prepared in “Required parts” in “5.1.2 Preparation” into the hole under the rotation prevention bolt and pull it out from the upper surface of the rotation unit.
- When the length of the tube over the upper surface reaches about 50 mm, temporarily secure the tube with masking tape so that it will not come off.

(The same work as in 5.3. See page 39.)

Rotation unit model number	Length of inserted tube
PAW-RU-8	553 mm
PAW-RU-X	653 mm
PAW-RU-Z	797 mm

5.6 Power Arm unit (the second arm from the bottom)

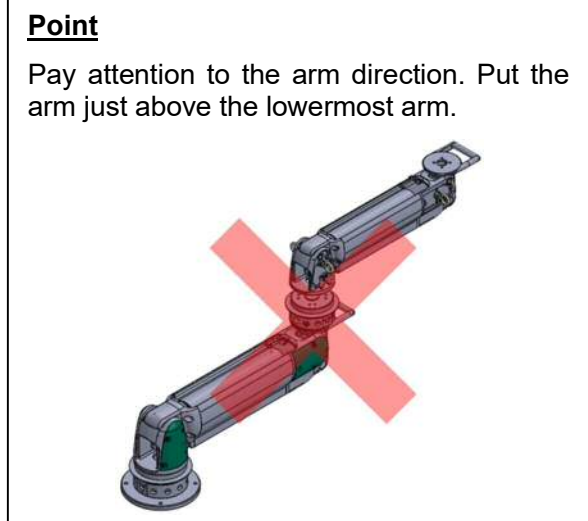
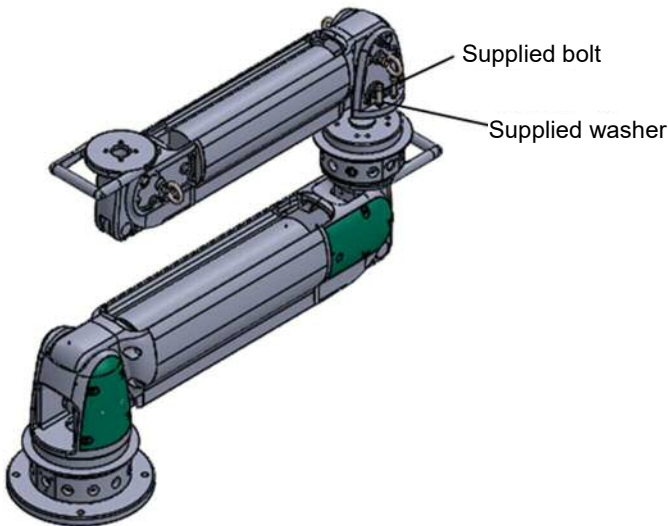

1. Remove the upper cover and rear cover of the Power Arm unit.
(The same work as in 5.4. See page 40.)
2. Place the Power Arm unit onto the boss of the rotation unit so that they are fitted.
(The same work as in 5.4. See page 40.)



- 
 In the case of model with rotation lock (option: L), insert the $\varnothing 4$ tube pulled out in "In the case of model with rotation lock (option: L)" in "5.5 Rotation unit (the second stage from the bottom)" into the mounting hole. Be careful not to pinch the tube.

3. Tighten the supplied bolts and washers.
(The same work as that in 5.4. See page 41.)

Power Arm unit model number	Tightening torque	Supplied bolt
PAW-AU-8	13N·m \pm 10%	M8 x 35
PAW-AU-X	25N·m \pm 10%	M10 x 40
PAW-AU-Z	43N·m \pm 10%	M12 x 45

- 
 Fit the washers without fail.
- 
 Apply adhesive to the bolts.

4. Remove the eyebolts and nuts and fit the supplied covers.
(Tightening torque: 1.3N·m \pm 10%)
(The same work as in 5.4. See page 41.)

- 
 Discard the removed eyebolts and nuts. They must not be reused.

[In the case of 2-axis model (PAW-M-[8S, XS, ZS, 8X, XZ])]

-> To Step 5.11 (Tubing, page 57)

**[In the case of 2-axis model with rotation mechanism at end
(PAW-M-[8S, XS, ZS, 8X, XZ]-(L)R)]**

-> To Step 5.9 (Rotation unit (rotation mechanism at end), page 51)

[In the case of 2-axis model with rotation lock (PAW-M-[8S, XS, ZS, 8X, XZ]-L)]

-> To Step 5.10 (Installation of rotation lock unit, page 54)

5.7 Rotation unit (the third stage from the bottom)

1. Place the boss of the rotation unit onto the center hole of the Power Arm unit so that they are fitted.
2. Adjust the direction using the position of the rotation prevention bolt as a guide.

[Bending direction: No symbol]PAW-M-[8XS,XZS,8XZ]

-> **Adjust so that the rotation prevention bolt is on the right side when viewed from the base plate.**
(On the same side as in the second rotation unit from the bottom)

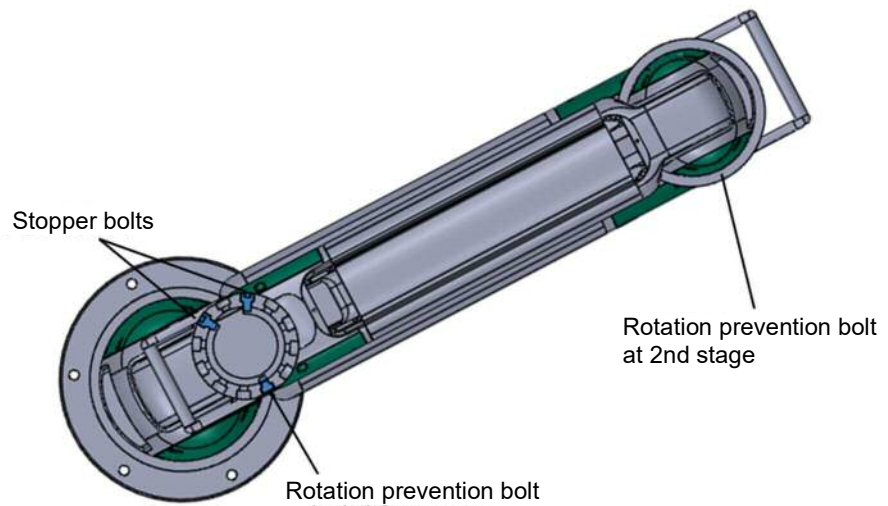

[Bending direction: C]PAW-M-[8XS,XZS,8XZ]-C

-> **Adjust so that the rotation prevention bolt is on the left side when viewed from the base plate.**
(On the same side as in the second rotation unit from the bottom)

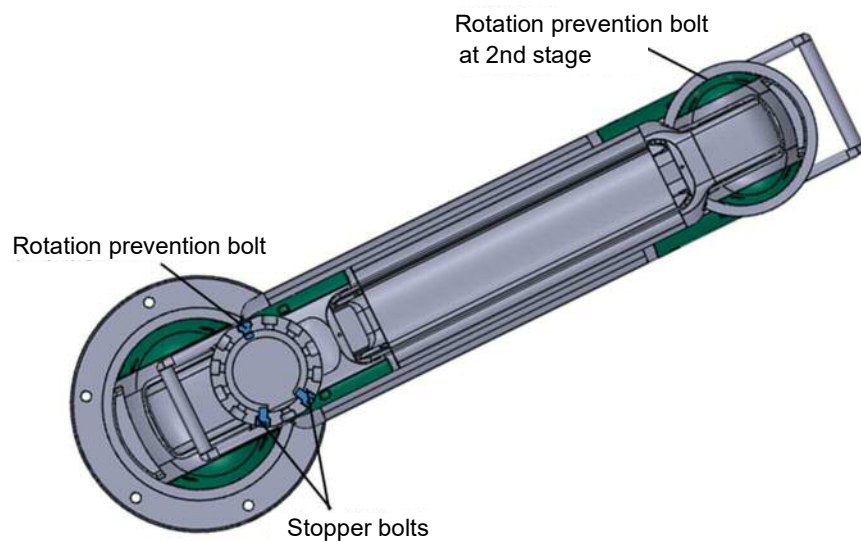

- Remove the stopper bolts, turn the mounting plate and tighten the supplied bolts and washers in the two positions.

(The same work as in 5.3. See page 38.)

Rotation unit model number	Tightening torque
PAW-RU-8	13N·m±10%
PAW-RU-X	25N·m±10%



- Assemble the washers without fail.
- Apply adhesive to the bolts.

- Return the mounting plate to the position shown in the figure below and insert the removed stopper bolts again.

(Similar work to that in 5.3. See page 39.)

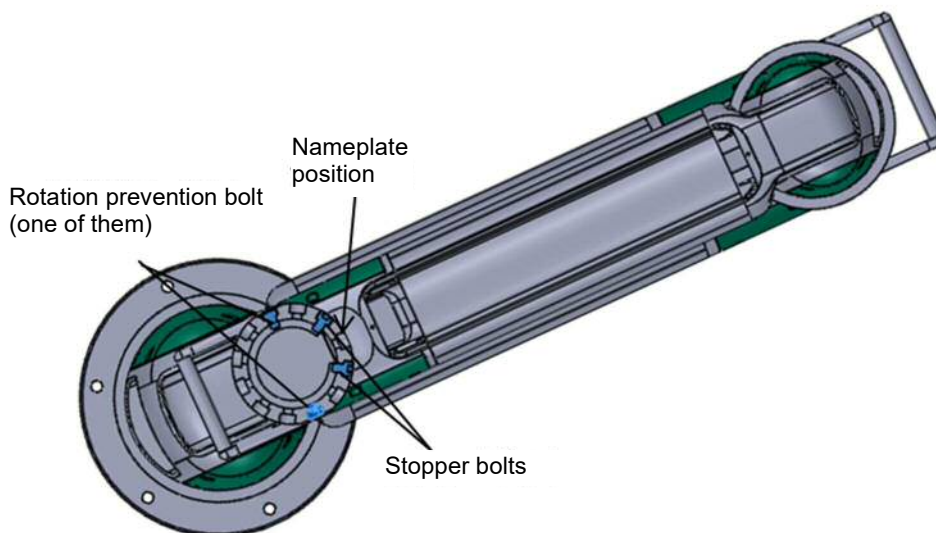

- After inserting the stopper bolts, make sure that the mounting plate does not rotate. If it rotates, correct the stopper bolt positions.

[Only in the case of model with rotation lock (option: L)]

- Insert the ø4 tube prepared in “Required parts” in “5.1.2 Preparation” into the hole under the rotation prevention bolt and pull it out from the upper surface of the rotation unit.
- When the length of the tube over the upper surface reaches about 50 mm, temporarily secure the tube with masking tape so that it will not come off.

(The same work as in 5.3. See page 39.)

Rotation unit model number	Length of inserted tube
PAW-RU-8	553 mm
PAW-RU-X	653 mm

5.8 Power Arm unit (the third arm from the bottom)

1. Remove the upper cover and rear cover of the Power Arm unit.
(The same work as in 5.4. See page 40.)
2. Place the Power Arm unit onto the boss of the rotation unit so that they are fitted.
(The same work as in 5.4. See page 40.)

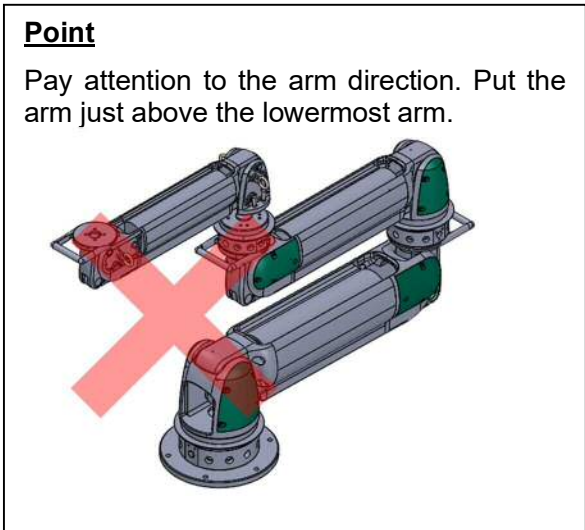
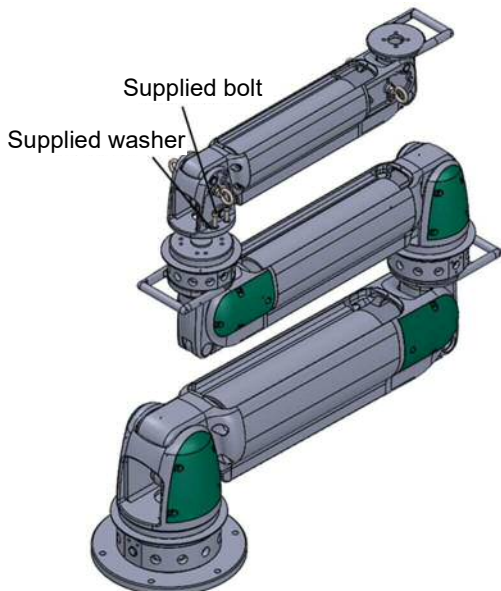

- 
 In the case of model with rotation lock (option: L), insert the $\varnothing 4$ tube pulled out in “In the case of model with rotation lock (option: L)” in “5.7 Rotation unit (the third stage from the bottom)” into the mounting hole. Be careful not to pinch the tube.

3. Tighten the supplied bolts and washers.
(The same work as that in 5.4. See page 41.)

Power Arm unit model number	Tightening torque	Supplied bolt
PAW-AU-8	13N·m±10%	M8 x 35
PAW-AU-X	25N·m±10%	M10 x 40

- 
 Fit the washers without fail.
- 
 Apply adhesive to the bolts.

4. Remove the eyebolts and nuts and fit the supplied covers.
(Tightening torque: 1.3N·m±10%)
(The same work as in 5.4. See page 41.)

- 
 Discard the removed eyebolts and nuts. They must not be reused.

[In the case of 3-axis model (PAW-M-[8XS, XZS, 8XZ])]

-> To Step 5.11 (Tubing, page 57)

**[In the case of 3-axis model with rotation mechanism at end
(PAW-M-[8XS, XZS, 8XZ]-(L)R)]**

-> To Step 5.9 (Rotation unit (rotation mechanism at end), page 51)

[In the case of 3-axis model with rotation lock (PAW-M-[8XS, XZS, 8XZ]-L)]

-> To Step 5.10 (Installation of rotation lock unit, page 54)

5.9 Rotation unit (rotation mechanism at end)

In case of model with rotation lock (option: L), refer to steps 1 to 10. In case of model without rotation lock, refer to steps 5 to 8.

[Only in the case of model with rotation lock (option: L)] (Steps 1 to 4)

1. Insert the $\varnothing 4$ tube prepared in "Required parts" in "5.1.2 Preparation" into the hole under the rotation prevention bolt as shown in the figure below and pull it out from the upper surface of the rotation unit.
2. When the length of the tube over the upper surface reaches about 50 mm, temporarily secure the tube with masking tape so that it will not come off.

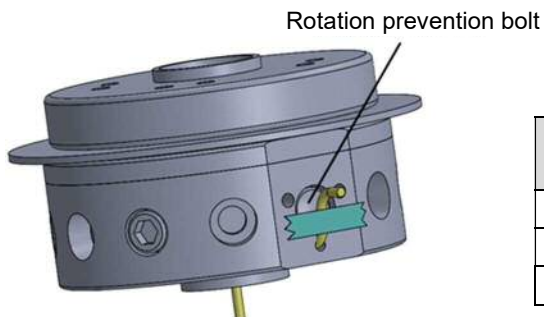

Rotation unit model number	Length of inserted tube
PAW-RU-T	538 mm
PAW-RU-8	628 mm
PAW-RU-X	732 mm

3. Insert the pulled $\varnothing 4$ tube into the center hole at the end of the Power Arm unit and draw the tube into the unit.
4. Insert the $\varnothing 4$ tube to the front of the fitting on the upper surface of the Power Arm unit.

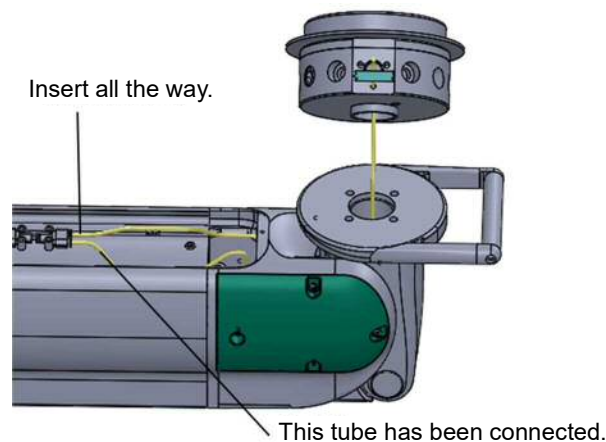

- Insert the tube securely all the way into the tube end and make sure that it does not come disconnected from the fitting before use.

Common to all models (steps 5 to 8)

5. Place the boss of the rotation unit onto the center hole in Power Arm unit so that they are fitted.



- In the case of model with rotation lock (option: L), be careful not to pinch the tube.

6. Adjust the direction using the position of the rotation prevention bolt as a guide.

[In the case of single-axis model] PAW-S-[8,X,Z]

[Number of axes: 2, Bending direction: No symbol] PAW-M-[8S,XS,ZS,8X,XZ]

[Number of axes: 3, Bending direction: C]..... PAW-M-[8XS,XZS,8XZ]-C

-> **Adjust so that the rotation prevention bolt is on the right side when viewed from the base plate.**

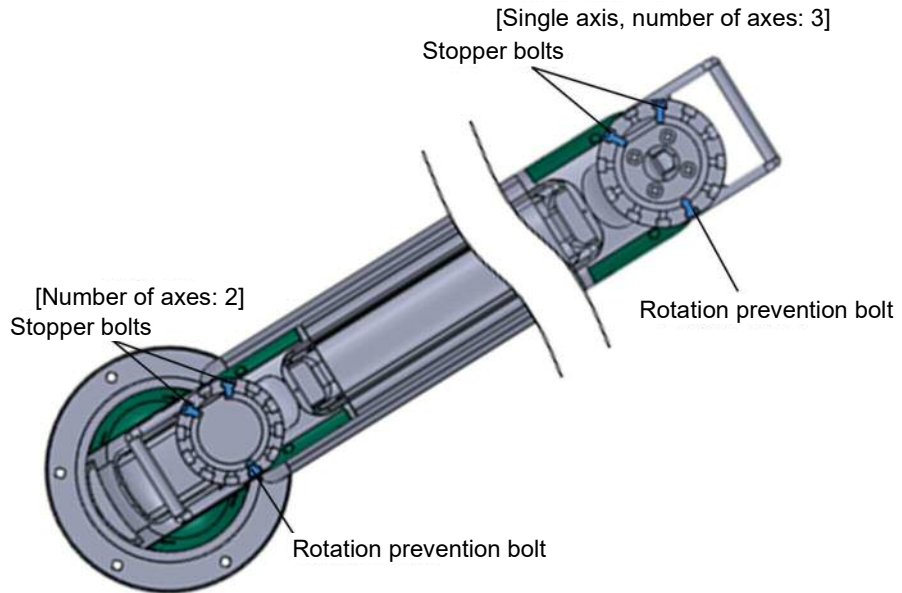

[Number of axes: 2, Bending direction: C]..... PAW-M-[8S,XS,ZS,8X,XZ]-C

[Number of axes: 3, Bending direction: No symbol] PAW-M-[8XS,XZS,8XZ]

-> **Adjust so that the rotation prevention bolt is on the left side when viewed from the base plate.**

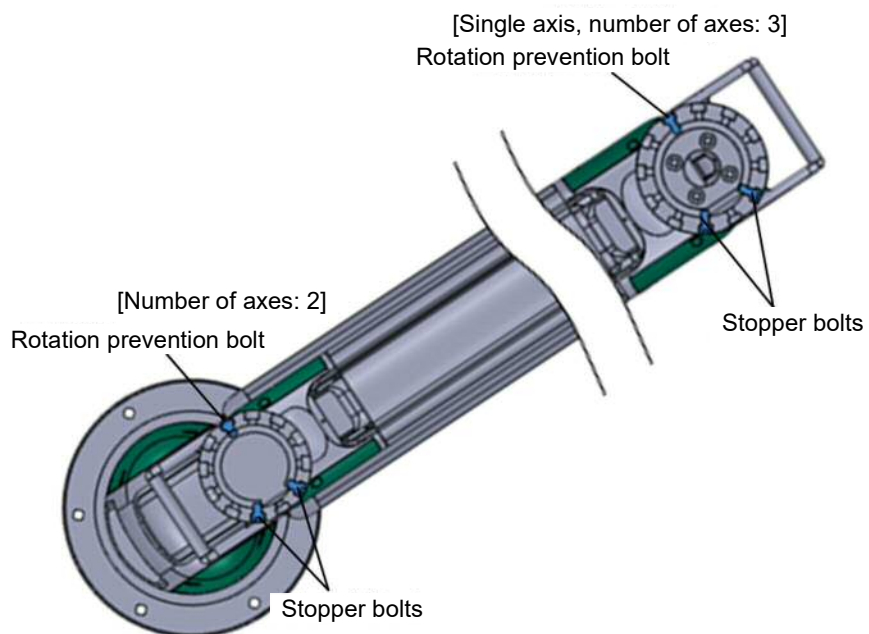

7. Remove the stopper bolts, turn the mounting plate and tighten the supplied bolts and washers in the two positions.

(The same work as in 5.3. See page 38.)

Rotation unit model number	Tightening torque
PAW-RU-T	13N·m±10%
PAW-RU-8	13N·m±10%
PAW-RU-X	25N·m±10%

!

- Assemble the washers without fail.
- Apply adhesive to the bolts.

8. Return the mounting plate to the position shown in the figure below and insert the removed stopper bolts again.

(Similar work to that in 5.3. See page 39.)

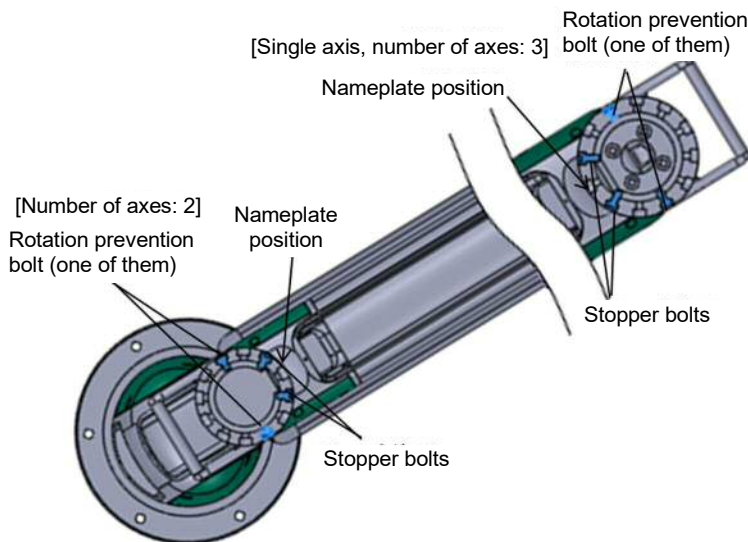

!

- After inserting the stopper bolts, make sure that the mounting plate does not rotate. If it rotates, correct the stopper bolt positions.

[In the case of model without rotation lock]

-> To Step 5.11 (Tubing, page 57)

[In the case of model with rotation lock (option: L)]

-> To Step 5.10 (Installation of rotation lock unit, page 54)

5.10 Rotation lock unit (In the case of model with rotation lock (option: L))



- Be sure to release lock (Supplying air or manual release) when removing stopper . And do not lock without lock disc or stopper.
- Do not supply air after manually releasing the lock.

* The rotation lock unit can be installed in the same manner on all types of lock unit installation.

1. Remove the two plugs (FPL-M5) of the rotation lock unit.
2. Screw the supplied hexagon socket head cap screws (M5 x 20) all the way in to release the lock and remove the stopper.

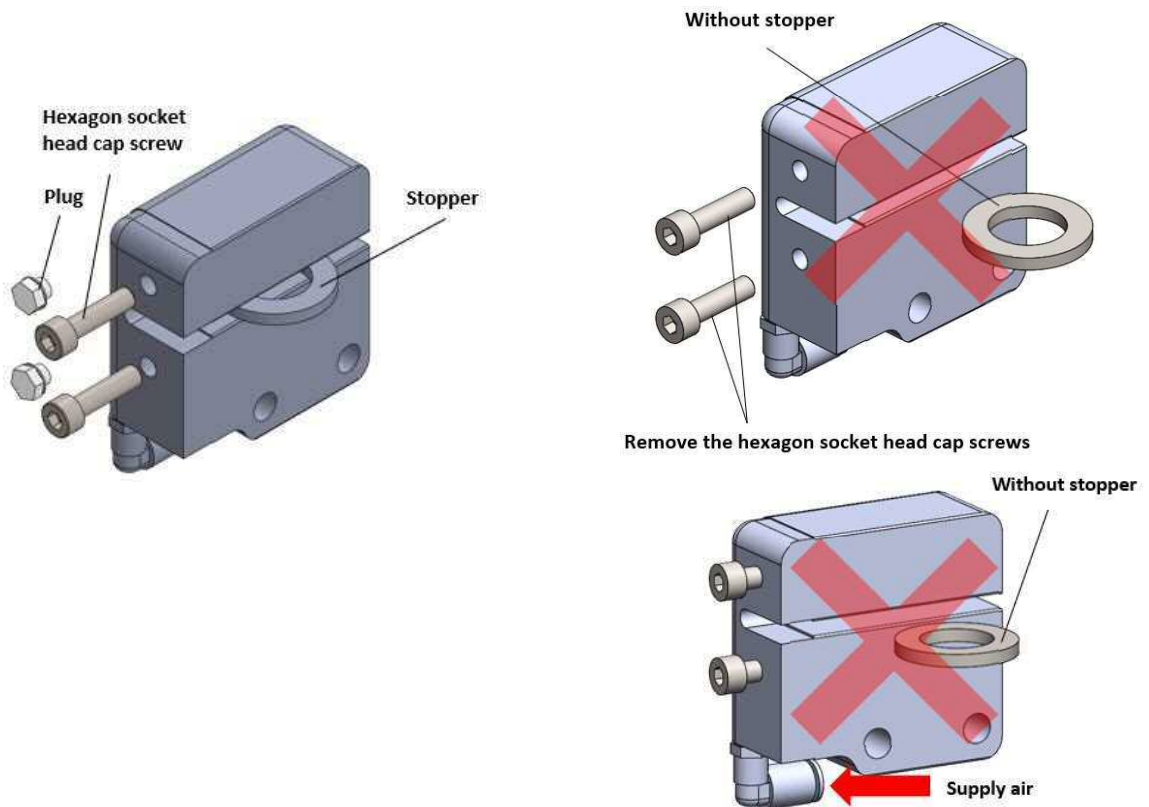



- Do not screw the bolts for manual release by tool (Hexagonal bar wrench).
- Do not turn the screws too tightly. The rotation lock unit will be damaged. Do not screw until less than 2-3mm.

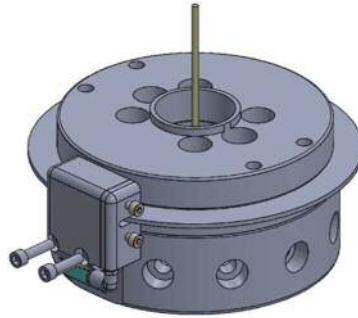

- Removed stopper is necessary for Lock unit maintenance or replacement. Keep the stopper after installing Lock unit.

3. Temporarily fit the rotation lock unit to the rotation unit with the supplied two M6 x 25 bolts.



	<ul style="list-style-type: none"> Before temporarily fitting the unit, apply adhesive to the bolts. After applying the adhesive, immediately fit and tighten the bolts. Do not leave the unit in the temporarily installed state.
	<ul style="list-style-type: none"> Brake shoe of Lock unit might come out because it is floating. In that case, it is hard to insert the brake shoe into Rotation lock unit because there is no clearance between upper and lower brake shoe. Push in the brake shoe using around 0.1mm shim plate, and insert the brake disk.

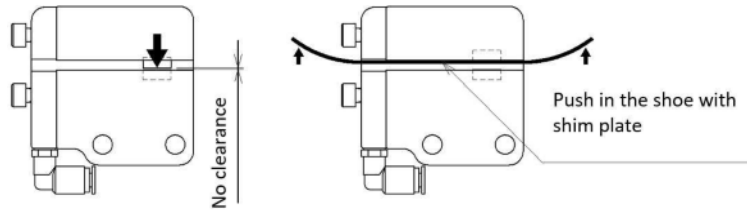

4. Insert the 0.2 mm(or 0.15mm) shims into the two positions on the right and left sides on the retaining disk as shown in the figure below.

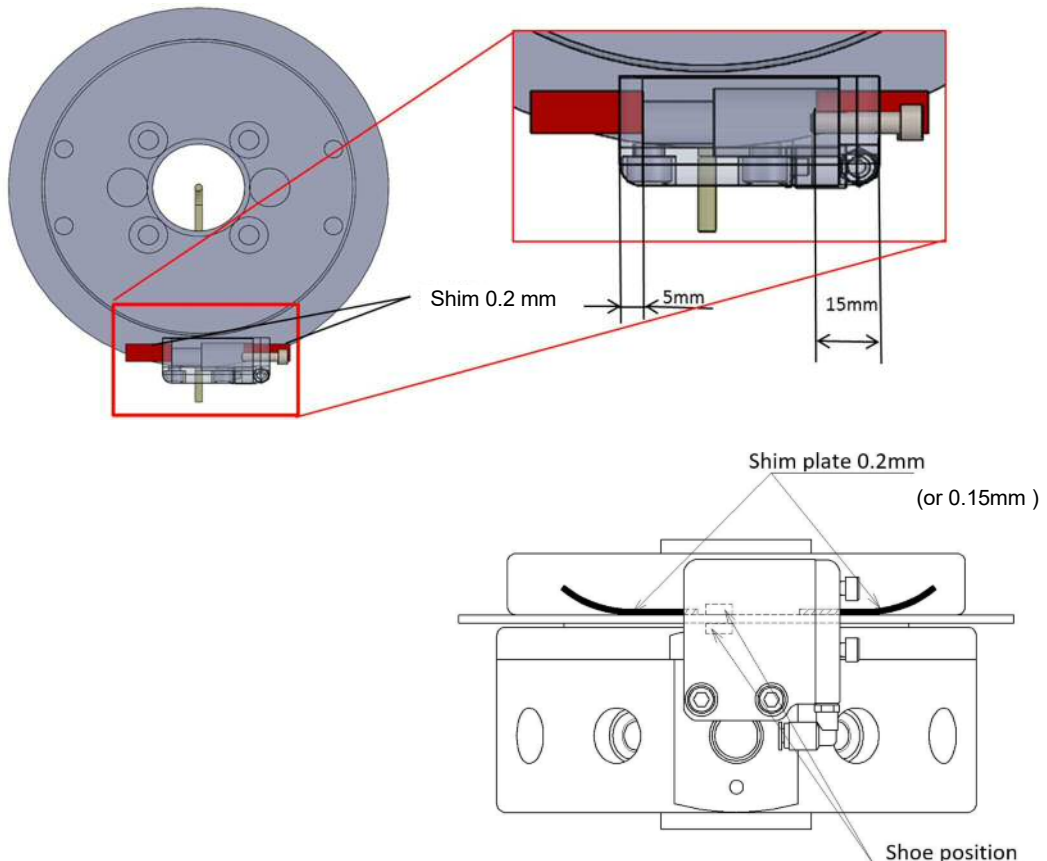

5. Lightly press down on the rotation lock unit to uniform the gap between the retaining disk and rotation lock unit, tighten the two temporarily fitted bolts and remove the shims.

(Tightening torque: $5N \cdot m \pm 10\%$)

Loosen and remove the two hexagon socket head cap screws that have been screwed into the unit.

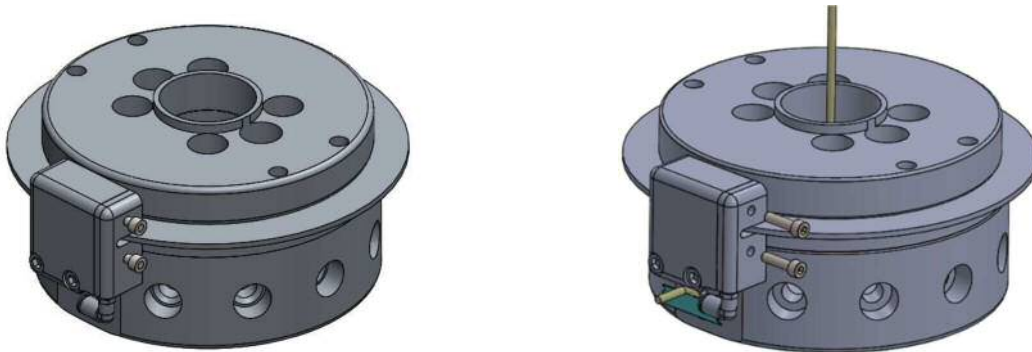

- The remove hexagon socket head cap screws will be required to manually release the lock. Keep them for future use.
- If they are lost, use hexagon socket head cap screws M5 x 20 of strength class 10.9 to 12.9 to manually release the lock.

6. Screw the two removed plugs (FPL-M5) into the threaded holes which the hexagon socket head cap screws are removed and tighten the plugs.

(Tightening torque: $1.3N \cdot m \pm 10\%$)

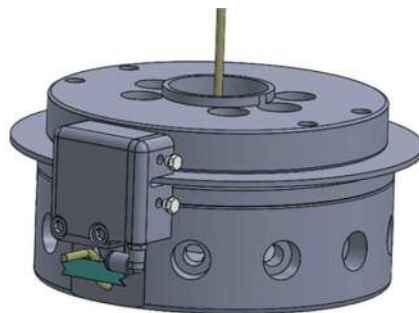

8. Insert the $\varnothing 4$ tube temporarily secured on the rotation unit into the fitting.

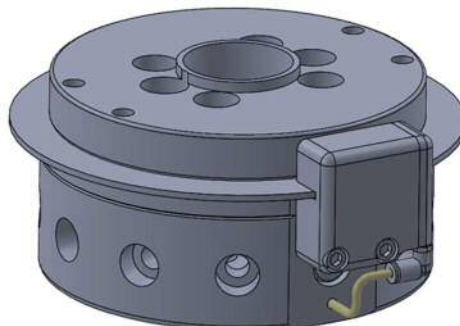

- Insert the tube securely all the way into the tube end and make sure that it does not come disconnected from the fitting before use.

5.11 Tubing

⚠ WARNING

Connect Air piping certainly. If the piping come out, dangerous situation will happen because Power Arm is fallen.

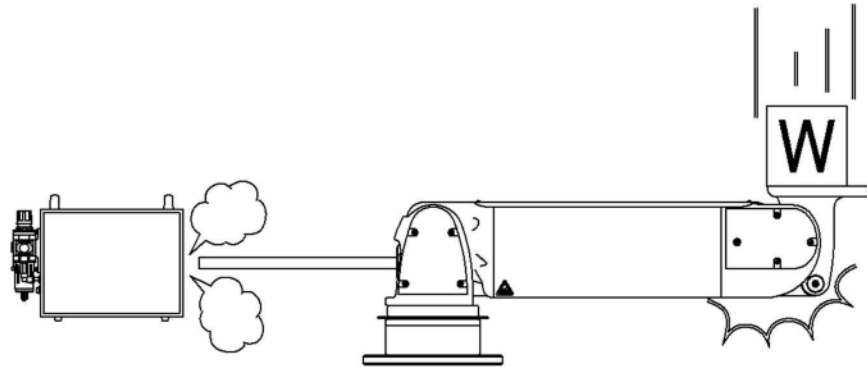

- Insert the tube and the blank plug securely all the way into the tube end and make sure that it does not come disconnected from the fitting before use.

5.11.1 Selection according to option

1. [In the case of model without rotation lock]
[In the case of model with rotation lock (option: L) and without rotation mechanism at end]

Insert the blank plug GWP4-B to the front of the fitting on the upper surface of the Power Arm unit of the uppermost arm.

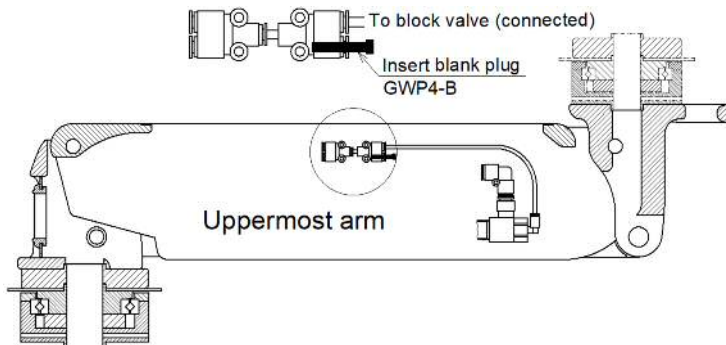

2. [In the case of model without rotation lock]

Insert the blank plug GWP4-B to the rear of the fitting on the upper surface of each Power Arm unit.

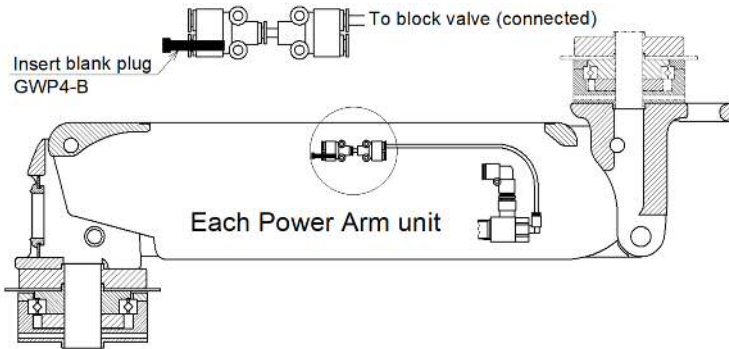

If the lowermost arm is the SCARA arm unit, place the fitting Y-shaped tee GWY44-0, and insert the blank plug GWP4-B into one insertion port.

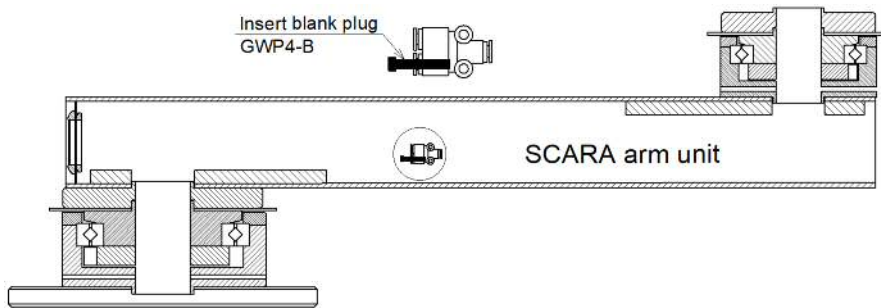

3. [In the case of model with rotation lock (option: L)]

Draw the $\varnothing 4$ tube from the upper surface of each rotation unit into the Power Arm unit, and insert the tube to the rear of the fitting on the upper surface of each Power Arm unit.

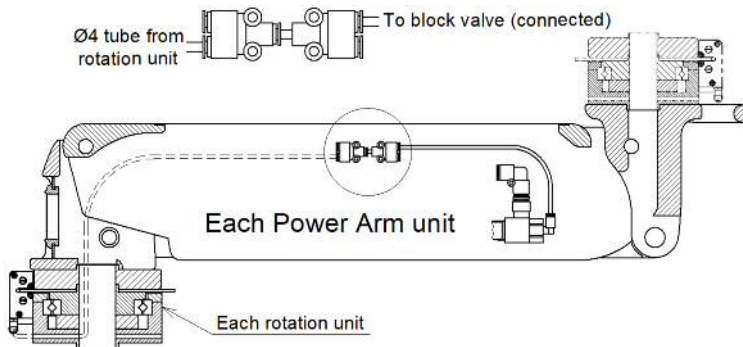

When the SCARA arm unit is installed on the lowermost arm, place the fitting Y-shaped tee GWY44-0, and insert the $\varnothing 4$ tube from the upper surface of the rotation unit into one insertion port.

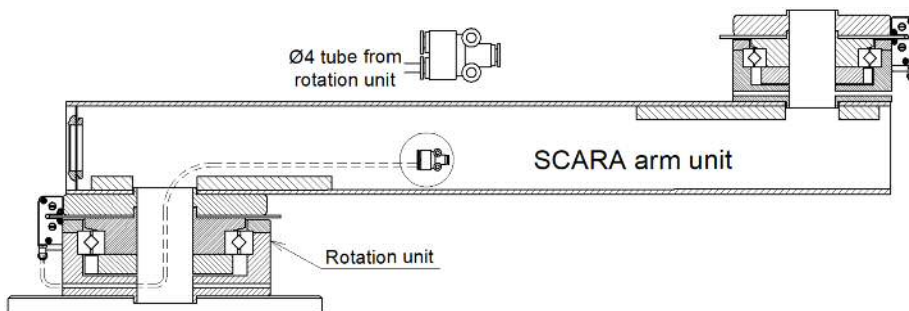

5.11.2 Common to all models

[Piping for unlocking (ø4)]

Lay the ø4 tube on each model as shown in each figure.

PAW – S - [8 , X , Z]

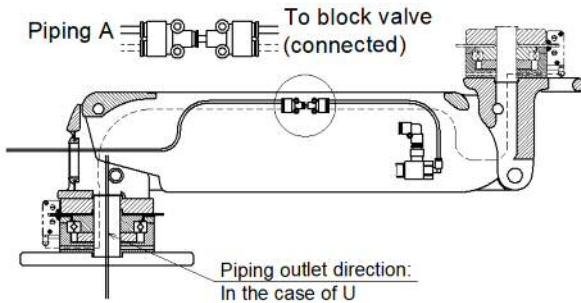

	Piping A
PAW-S-8	2314 mm
PAW-S-X	2393 mm
PAW-S-Z	2446 mm

PAW – M - [8S , XS , ZS]

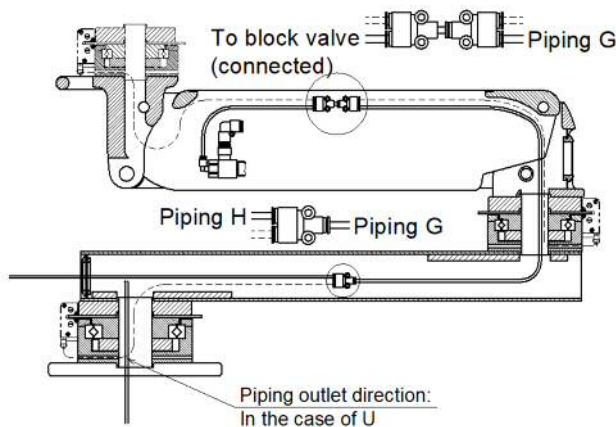

	Piping G	Piping H
PAW-M-8S	688 mm	2446 mm
PAW-M-XS	790 mm	2577 mm
PAW-M-ZS	970 mm	2713 mm

PAW - M - [8X , XZ]

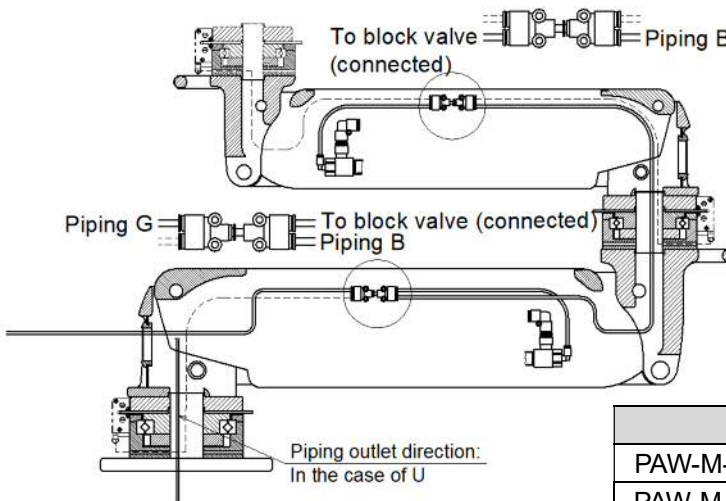

	Piping B	Piping C
PAW-M-8X	950 mm	2393 mm
PAW-M-XZ	1150 mm	2446 mm

PAW – M - [8XS , XZS]

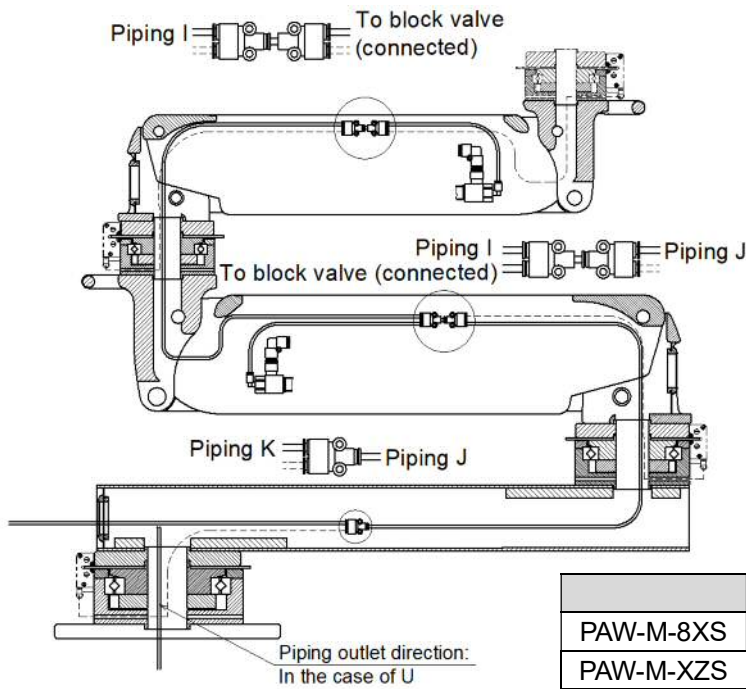

	Piping I	Piping J	Piping K
PAW-M-8XS	950 mm	790 mm	2577 mm
PAW-M-XZS	1150 mm	970 mm	2713 mm

PAW – M - [8XZ]

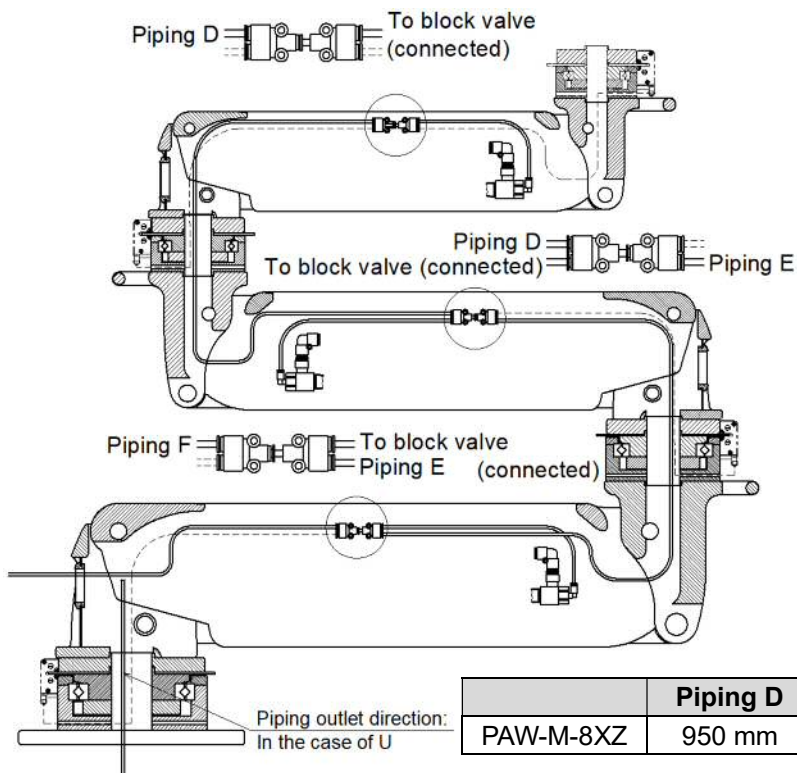

	Piping D	Piping E	Piping F
PAW-M-8XZ	950 mm	1150 mm	2446 mm

[Piping for cylinder (ø8 and ø10 tubes)]

Connect the ø8- and ø10 wear-resistant tubes on each model as shown in each figure.

- To protect the pipe for cylinder from friction and wear, check the position inside the Power Arm unit and the center hole of the rotation unit referring to the figure below and wind the spiral tube when piping.
- For the recommended spiral tubes, refer to “5.1.1 Preparation”.

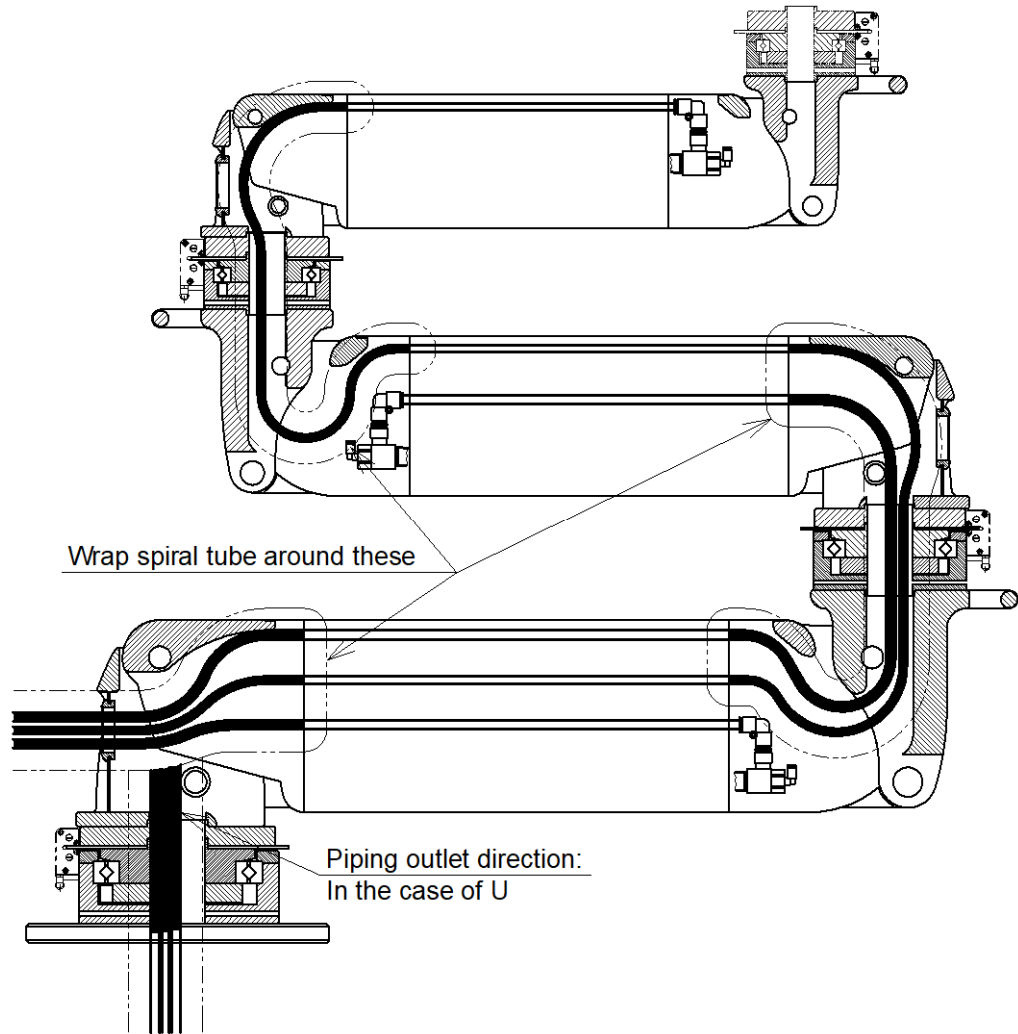

PAW – S - [8 , X , Z]

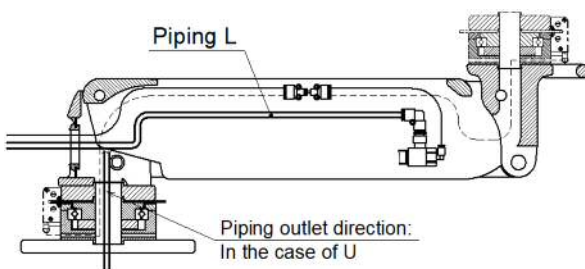

	Piping L
PAW-S-8	Ø8 Tube 2576 mm
PAW-S-X	Ø10 Tube 2685 mm
PAW-S-Z	Ø10 Tube 2776 mm

PAW – M - [8S , XS , ZS]

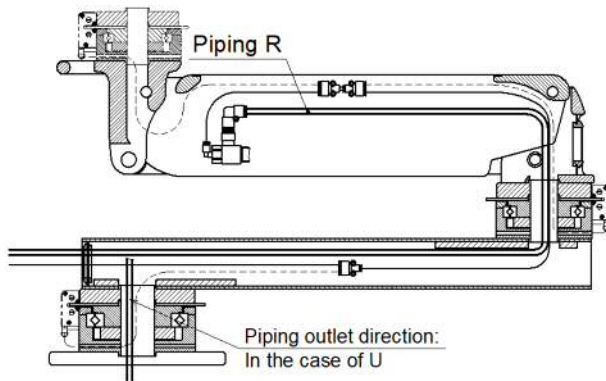

	Piping R
PAW-M-8S	Ø8 Tube 3398 mm
PAW-M-XS	Ø10 Tube 3640 mm
PAW-M-ZS	Ø 10Tube 3958 mm

PAW - M - [8X , XZ]

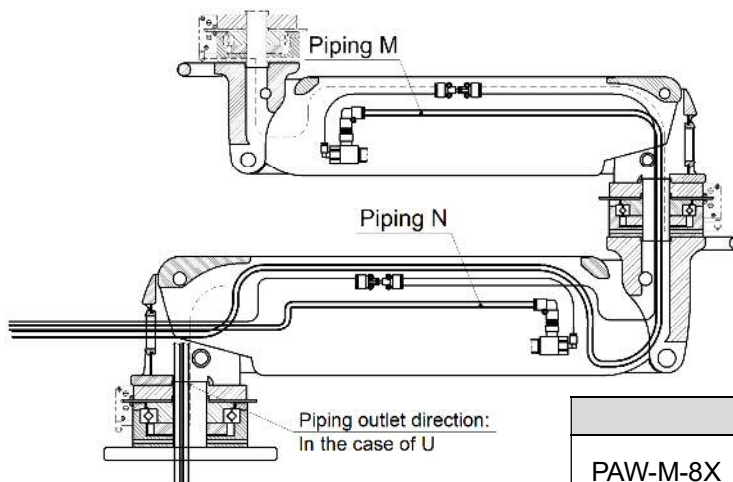

	Piping M	Piping N
PAW-M-8X	Ø8 Tube 3564 mm	Ø10 Tube 2685 mm
PAW-M-XZ	Ø10 Tube 3900 mm	Ø10 Tube 2776 mm

PAW – M - [8XS , XZS]

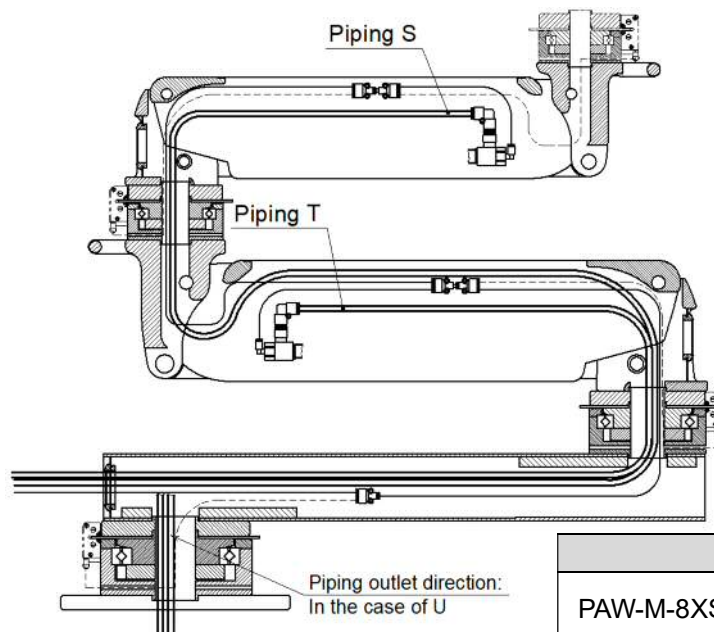

	Piping S	Piping T
PAW-M-8XS	Ø8 Tube 4625 mm	Ø10 Tube 3640 mm
PAW-M-XZS	Ø10 Tube 5050 mm	Ø10 Tube 3958 mm

PAW – M - [8XZ]

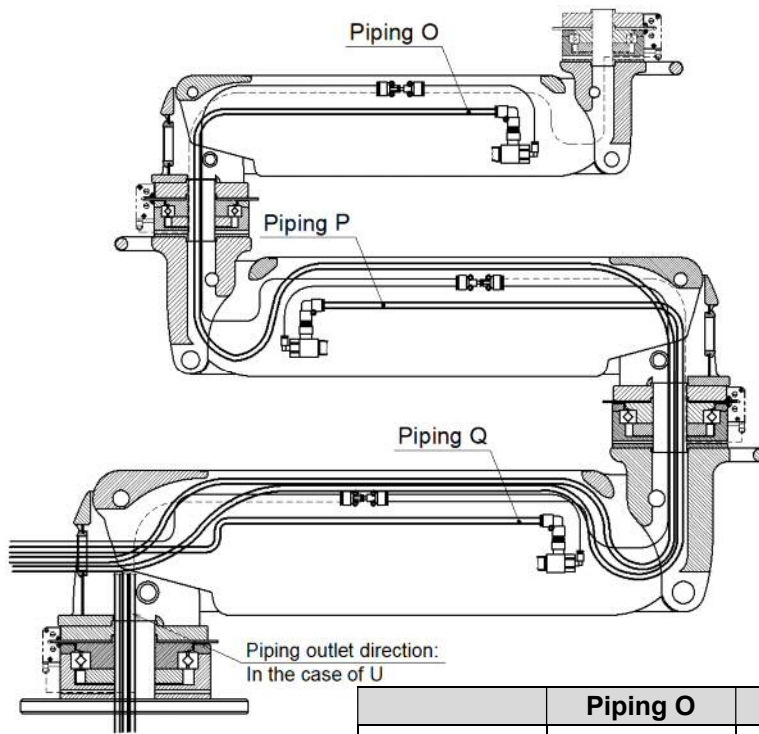

	Piping O	Piping P	Piping Q
PAW-M-8XZ	Ø8 Tube 4882 mm	Ø10 Tube 3900 mm	Ø10 Tube 2776 mm





- When piping the tubes, be careful not to twist or bend them or entangle them with other pipes.

5.11.3 Supplying air

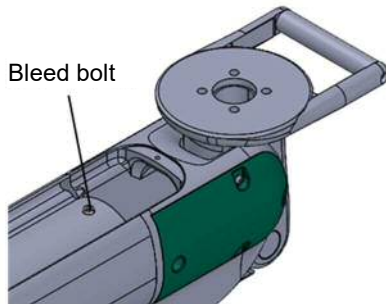
1. Loosen the bleed bolt marked in yellow on each Power Arm unit two or three turns and leave the unit for one to two minutes to discharge the residual pressure in the cylinder.
2. After discharging the pressure, tighten the bleed bolt to the specified tightening torque to close the bolt.
(Tightening torque: $1.3\text{N}\cdot\text{m} \pm 10\%$)



- 
 - If the bleed bolt is excessively tightened, it may be damaged. Tighten it to the specified tightening torque.
- 
 - The bleed bolts cannot be removed. If they are forcibly removed, they may be damaged. Do not remove them.

3. Connect the air equipment (for the air equipment used, refer to Required pneumatic equipment in “2.7 Installation Method of Unit Product”) as shown in the figure below, make sure that the manual changeover valve is NC and the secondary pressure of each precision regulator is 0. Then, supply clean compressed air of 0.5MPa to the primary side.

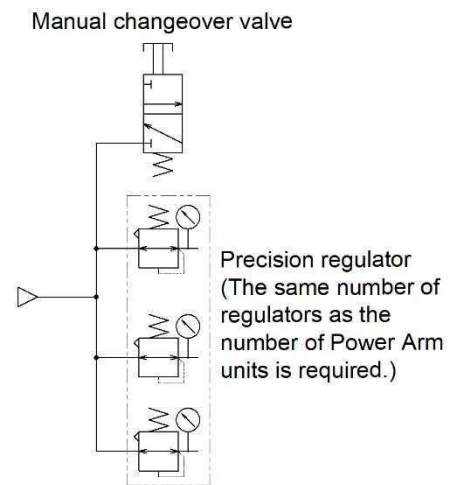

4. Connect the pipe for unlocking ($\varnothing 4$ tube) running from the lowermost arm to the manual changeover valve and connect the piping for cylinder ($\varnothing 8$ and $\varnothing 10$ tube) to each precision regulator.

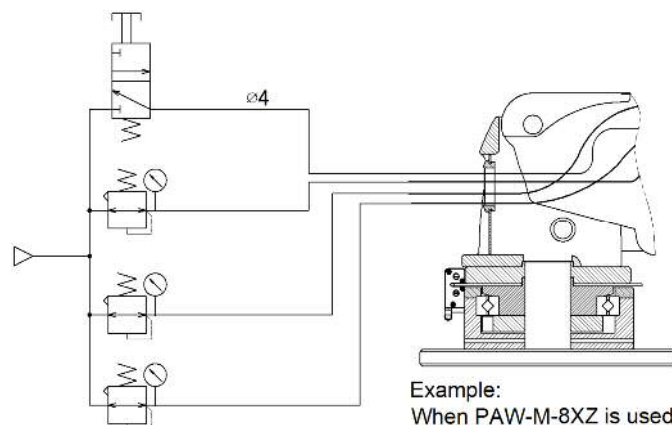

5. Switch the manual changeover valve to release the lock.
6. Gradually open the pressure adjustment knob of the precision regulator connected to the pipe for cylinder of the uppermost arm unit until the tip of the arm moves up.



- The arm will move up. Before opening the knob, make sure that there are no persons, machines and tools above the arm.



- Do not quickly open the pressure adjustment knob. The arm will move up suddenly and it may cause a hazardous situation.

7. When moving up and down the arm by the handle, adjust the pressure with the precision regulator so that the upward and downward operating forces are equal to each other at an arm angle of 30 to 40°. After the completion of pressure adjustment, tighten the lock nut of the precision regulator to secure the knob.



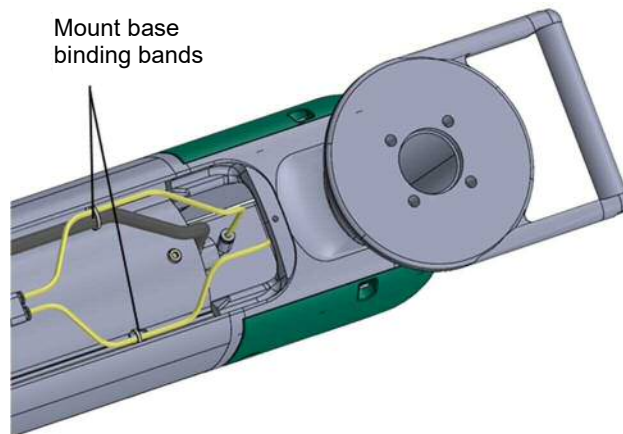

- When the pressure has been adjusted appropriately, the arm is apt to move up near the lowermost position, move down in the range from the center to the upper position and move up near the uppermost position.

8. In the case of a multi-axis model, adjust the pressure with the precision regulators of the second and third arms from the top. After the completion of pressure adjustment, tighten the lock nut of the precision regulator to secure the knob.
9. Secure the pipe on the mount base with binding bands starting from the upper tube while holding the handle and operating the arm continuously from the upper most position to the lowermost position to confirm that the pipe for unlocking and pipe for cylinder are not excessively pulled or loosened.



- Do not tighten the binding bands too tightly. The tube may be crushed and the air flow may be disturbed.

10. Gradually close the pressure adjustment knobs of all precision regulators to set the secondary pressure to 0.

	<ul style="list-style-type: none"> ▪ The arm will move down. Before closing the knobs, make sure that there are no persons, machines and tools under the arm. ▪ Before switching the manual changeover valve in the next process, set the secondary pressure to 0. Otherwise, residual pressure will remain in the cylinder.
	<ul style="list-style-type: none"> ▪ Do not quickly close the pressure adjustment knobs. The arm will move down suddenly and it may cause a hazardous situation.

11. Switch the manual changeover valve to lock the arm.

12. Disconnect the pipe for unlocking from the manual changeover valve and disconnect the pipe for cylinder from each precision regulator.

13. Fit the covers except the piping outlet cover of the lowermost arm.

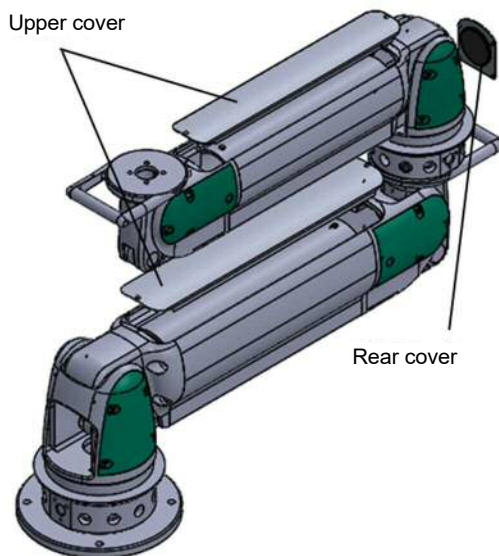

Parts name	Tightening torque
Power Arm unit cover and rear cover	1.3N·m±10%
SCARA arm unit front cover and rear cover	3.2N·m±10%

[Direction of leading out the piping: Only in the case of no symbol]

14. Make a cross cut in the grommet diaphragm on the cover of the piping outlet of the lowermost arm.



	<ul style="list-style-type: none"> ▪ Handle a knife carefully. When working with a knife, wear protective gloves to protect your hands and fingers.
---	--

[Direction of leading out the piping: Only in the case of no symbol]

15. Pass the piping for unlocking and the piping for cylinder through the grommet hole and fit the piping outlet cover.

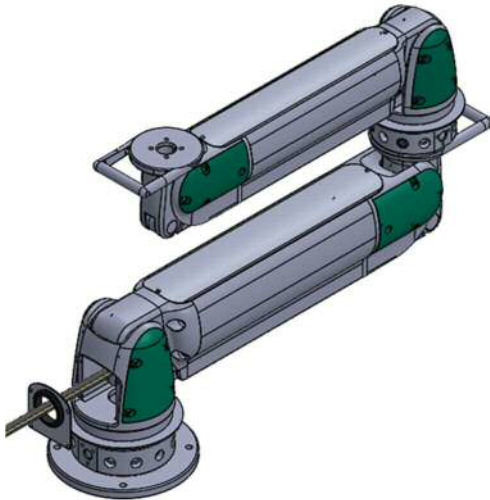



Parts name	Tightening torque
Power Arm unit rear cover	1.3N·m±10%
SCARA arm unit rear cover	3.2N·m±10%

16. Bundle the piping for unlocking and piping for cylinder and wrap the spiral tube around them.

Direction of leading out piping: No symbol

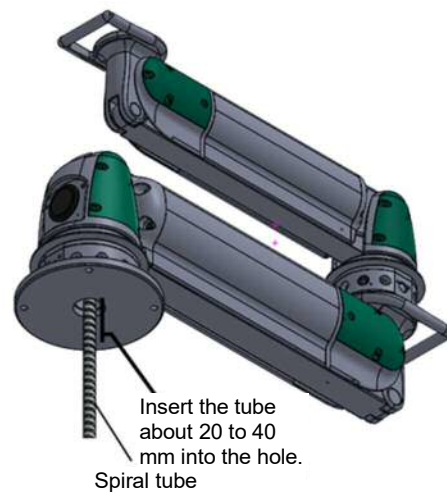
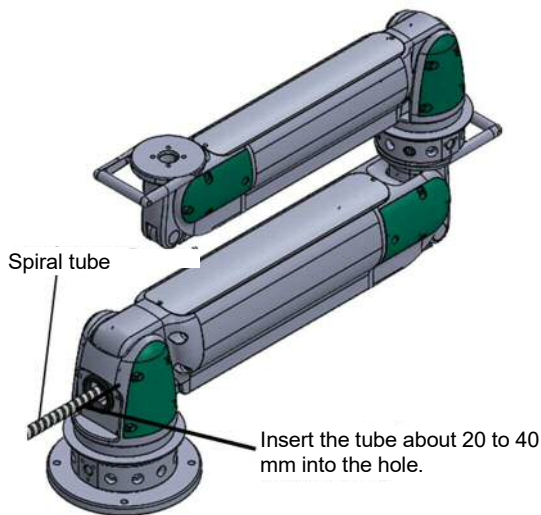
Direction of leading out piping: U



- 
 - When wrapping the spiral tube, push the tube to insert the tube about 20 to 40 mm into the piping outlet cover.
- 
 - Take care not to crush the piping or apply tension stress to it.

17. Cutting the end of the pipe, to align the length.

6. MAINTENANCE AND INSPECTION

6.1 Periodic Inspection

In order to use the product safely under optimum conditions, an operator or a maintenance person must perform a periodic inspection every day.

Inspection item

Inspect the following items to make sure that there is no abnormality with the product. If there is an abnormality, stop using the product, have a repair person check the situation, and take measures.

Inspection item	Action
Check that the mounting bolts securing the base plate are not loose.	Tighten the bolts with appropriate tightening torque.
Check that the bolts securing the jig to the Power Arm end are not loose.	Tighten the bolts with appropriate tightening torque.
Check that there is no contamination or peeling of the warning labels.	Clean and re-apply the warning labels.
Check that there are no dents or damage on the product.	Replace the relevant unit. ^{Note 1}
Check that the operation is smooth (no abnormal resistance or noise during up-down movement and turning).	Since the parts of the unit are damaged or deformed, replace the relevant unit. ^{Note 1}
Check that there is no abnormality with operating the product in the movable range.	Since the parts of the unit are damaged or deformed, replace the relevant unit. ^{Note 1}
Check that there is no abnormality with the locking mechanism (arms do not move vertically and do not rotate in the locked state).	Since the parts of the unit are damaged or deformed, replace the relevant unit. ^{Note 1}
Check that there are no air leakage from piping parts and deterioration of piping materials or tubes.	Replace the piping materials and tubes.

Note 1: Do not disassemble the units. If the units are disassembled, their original performance and accuracy may not be restored.

If any unit must be overhauled, contact CKD.

6.2 Periodic maintenance parts



- The consumable parts must be replaced by a repair person.



- Before replacing any part, shut off the air supply and switch the shut-off valve to discharge the residual pressure.
During replacement, lock the shut-off valve in the “Discharge position”.

Part name	Model number of part	Model number of relevant unit	Standard replacement period ^{Note 1}
Stopper bolt	PAW-RU-T-STB-KIT	PAW-RU-T	20,000 operations or 1 year ^{Note 2}
	PAW-RU-8-STB-KIT	PAW-RU-8	
	PAW-RU-X-STB-KIT	PAW-RU-X	
	PAW-RU-Z-STB-KIT	PAW-RU-Z (Note 3)	
	PAW-RU-ZS-STB-KIT	PAW-RU-ZS	
Rotation prevention bolt	PAW-RU-T-ARB-KIT	PAW-RU-T	100,000 operations or 5 years (20,000 operations or 1 year when used as a rotation stopper instead of using the stopper bolt)
	PAW-RU-8-ARB-KIT	PAW-RU-8	
	PAW-RU-X-ARB-KIT	PAW-RU-X	
	PAW-RU-Z-ARB-KIT	PAW-RU-Z (Note 3)	
	PAW-RU-ZS-ARB-KIT	PAW-RU-ZS	
Spiral tube Binding band	Refer to “Required members” in “5.1 Preparation”		100,000 operations or 5 years
Tube	Refer to “Required members” in “5.1 Preparation”		

Note 1: These values are not guaranteed because they differ depending on the frequency of use and the condition of use.

Note 2: This is an approximation calculated as follows: 80 operations/day (up-down movement) × 240 days/year.

Note 3: Please confirm serial No. of PAW when ordering Stopper bolt KIT(PAW-RU-Z-STB-KIT) or Rotation prevention bolt KIT(PAW-RU-Z-ARB-KIT).

【Stopper bolts 、 Rotation prevention bolt】

•The thread size of the stopper bolt and width of the hexagonal hole are as follows.

Use a compatible hexagonal wrench.。

Model number of part	thread size of the stopper bolt	width of the hexagonal hole
PAW-RU-T-STB-KIT / PAW-RU-T-ARB-KIT	M10	8
PAW-RU-8-STB-KIT / PAW-RU-8-ARB-KIT	M12	10
PAW-RU-X-STB-KIT / PAW-RU-X-ARB-KIT	M12	10
PAW-RU-Z-STB-KIT / PAW-RU-Z-ARB-KIT	M16 (Note4)	14 (Note4)
PAW-RU-ZS-STB-KIT / PAW-RU-ZS-ARB-KIT	M16	14

Note 4) The stopper bolt of PAW-RU-Z has been changed from SM-A13989/5 to M16.。

Note 5) When installing or removing the stopper bolt, pay attention to the total length of the stopper bolt and reassemble it. (See page 31)

7. TROUBLESHOOTING

Problems, Causes, and Solutions

When any problem occurs during use of the product, stop using the product, have a maintenance person (or a repair person depending on the item) to check the situation, and take measures.

Problem	Cause	Solution
Product does not operate.	No pressure or insufficient pressures are applied to product.	Connect pressure sources.
	Power Arms are locked.	Supply air to the piping for releasing the lock.
Power Arms do not move up.	Load capacity is exceeded.	Reduce the weight of the transfer object.
		Increase the pressure in the pipe for cylinder.
Upward and downward operating forces are uneven.	Pressures adjusted by precision regulator (electro-pneumatic regulator) are high or low.	Re-adjust the pressures with the precision regulator (electro-pneumatic regulator).
Power Arms cannot be held in place in the rotation direction.	Installation surface is not horizontal.	Ask a repair person to level the installation surface.
Stopper bolt on Rotation unit was broken. (Angular range was expanded from intended range.)	Stopped rotating Power arm using stopper bolts.	Remove broken piece of stopper bolt from maintenance hole. And ,replace stopper bolt (See page 31) Stop rotating operation before stopper plate hit stopper bolt.

8. Disposal

8.1 Dismantling



- The units shall be dismantled by a service person who has sufficient knowledge of machine assembly and pneumatic equipment assembly.

When dismantling the product, at first, remove all jigs and attachments from the end, and dismantle it in order from the top in the reverse procedure to 5 “Assembly of unit product.”

Some of the Power Arm units, rotation units, SCARA arm units and base plates are heavy. Dismantle the heavy units with a crane.



- The crane shall be operated by qualified experts wearing protective equipment such as helmets and safety shoes and the lifting height shall be the minimum necessary.
- Use wire ropes or belt slings having sufficient safety load for the weight of the multi-axis product.
- When moving and installing the product, hoist or lift in a well-balanced state (at first, hoist or lift it slightly and make sure that it is well-balanced before transporting).

Prepare hoisting attachments as needed.

Unit name	Required parts
Rotation unit PAW-RU-ZS	M16 eyebolt: 2 pcs. M16 hexagon nut (type 1): 2 pcs.
SCARA arm unit PAW-SU-XS	M10 eyebolt: 2 pcs. M12 eyebolt: 2 pcs. M10 hexagon nut (type 1): 2 pcs. M12 hexagon nut (type 1): 2 pcs.
SCARA arm unit PAW-SU-ZS	M12 eyebolt: 2 pcs. M16 eyebolt: 2 pcs. M12 hexagon nut (type 1): 2 pcs. M16 hexagon nut (type 1): 2 pcs.
Base plate PAW-BP-ZS	M14 eyebolt: 2 pcs. M14 hexagon nut (type 1): 2 pcs.

* Use eyebolts and hexagon nuts (type 1) (made of steel) conforming to the standards (ISO/IEC, JIS, etc.) in the user's country and region.

Units not shown above weigh 15 kg or less and do not need hoisting attachments. Handle the units taking great care not to drop them or pinch your fingers.

8.2 Disposal

When disposing of the product, follow the local laws and government ordinances.

9. Declaration of CE conformity

CE/UKCA Declaration of Conformity is open to public on CKD website.

<https://www.ckd.co.jp/productinfo/eu/>

10. WARRANTY PROVISIONS

10.1 Warranty Conditions

■ Warranty coverage

If the product specified herein fails for reasons attributable to CKD within the warranty period specified below, CKD will promptly repair the faulty product at one of CKD's facilities free of charge.

However, following failures are excluded from this warranty:

- Failure caused by handling or use of the product under conditions and in environments not conforming to those stated in the catalog, the Specifications, or this Instruction Manual.
- Failure caused by use or management that violates the "DANGER", "WARNING", and "CAUTION" precautions and other instructions stated in the catalog, the Specifications, or this Instruction Manual.
- Failure not caused by the product.
- Failure caused by use not intended for the product.
- Failure caused by modifications/alterations or repairs not carried out by CKD.
- Failure that could have been avoided if the machinery or device of another manufacturer, which is attached to the product when in use, had been subjected to risk assessments that are defined and required in the product safety standards such the basic safety standards, the group safety standards, and the individual machinery safety standards classified according to ISO/IEC Guide 51 and had functions and structures for securing safety.
- Failure caused by reasons unforeseen at the level of technology available at the time of delivery.
- Failure caused by acts of nature and disasters beyond control of CKD.

The warranty stated herein covers only the delivered product itself. Any loss or damage induced by failure of the delivered product is excluded from this warranty.

■ Confirmation of product compatibility

It is the responsibility of the customer to confirm compatibility of the product with any system, machinery, or device used by the customer.

■ Others

The terms and conditions of this warranty stipulate basic matters.

When the terms and conditions of the warranty described in individual specification drawings or the Specifications are different from those of this warranty, the specification drawings or the Specifications shall have a higher priority.

10.2 Warranty Period

The product is warranted for one (1) year from the date of delivery to the location specified by the customer.

10.3 Remarks

- Warranty period specified in 6.2 is based on the assumption that the number of operations does not exceed 100,000 in one (1) year. If the number of operations reaches 100,000 within one (1) year, the warranty shall expire at that time.
- If the product is exported outside Japan by the customer, it shall be repaired if returned to CKD's facility or a company or plant specified by CKD. Work and cost associated with the return shall not be covered by the warranty. The repaired product shall be delivered to a place in Japan specified by the customer in a package appropriate for delivery in Japan.



Japan

CKD Corporation
2-250 Uji, Komaki, Aichi 485-8551, Japan
Phone: +81-(0)568-74-1338 Fax: +81-(0)568-74-1165

China

CKD (Shanghai) Corporation
Room 612, 6th Floor, Yuanzhongkeyan Building, No. 1905
Hongmei Road, Xuhui District, Shanghai 200233, China
Phone: +86-(0)21-60906046/7/8 Fax: +86-(0)21-60906046

Taiwan

Taiwan CKD Corporation
16F-3, No. 7, Sec. 3, New Taipei Blvd., Xinzhuang Dist.,
New Taipei City 242, Taiwan
Phone: +886-(0)2-8522-8198 Fax: +886-(0)2-8522-8128

Korea

CKD Korea Corporation
(3rd Floor), 44, Sinsu-ro, Mapo-gu, Seoul 04088, Korea
Phone: +82-(0)2-783-5201/5202/5203 Fax: +82-(0)2-783-5204

Malaysia

M-CKD Precision Sdn. Bhd.
Lot No. 6, Jalan Modal 23/2, Seksyen 23, Kawasan, MIEL,
Fasa 8, 40300 Shah Alam, Selangor Darul Ehsan, Malaysia
Phone: +60-(0)3-5541-1468 Fax: +60-(0)3-5541-1533

Singapore

CKD Singapore Pte. Ltd.
33 Tannery Lane, #04-01 Hoesteel Industrial Building,
Singapore 347789, Singapore
Phone: +65-6744-2623 Fax: +65-67442486

CKD Corporation Branch Office
33 Tannery Lane, #04-01 Hoesteel Industrial Building,
Singapore 347789, Singapore
Phone: +65-6744-7260

Thailand

CKD Thai Corporation Ltd.
44, Smooth Life Tower, 19th Floor, Unit 1902,
North Sathorn Road, Silom, Bangrak, Bangkok 10500, Thailand
Phone: +66-(0)2-267-6300 Fax: +66-(0)2-267-6304/6305

Vietnam

CKD Vietnam Engineering Co., Ltd.
18th Floor, CMC Tower, Duy Tan Street, Cau Giay District,
Hanoi, Vietnam
Phone: +84-(0)24-3795-7631 Fax: +84-(0)24-3795-7637

Indonesia

PT CKD Trading Indonesia
Menara Bidakara 2, 18th Floor, Jl. Jend. Gatot Subroto
Kav. 71-73, Pancoran, Jakarta 12870, Indonesia
Phone: +62-(0)21-2938-6601 Fax: +62-(0)21-2906-9470

India

CKD India Private Limited
Unit No. 607, 6th Floor, Welldone Tech Park, Sector 48,
Sohna Road, Gurgaon-122018, Haryana, India
Phone: +91-(0)124-418-8212

U. S. A.

CKD USA Corporation
1605 Penny Lane, Schaumburg, IL 60173, USA
Phone: +1-847-648-4400 Fax: +1-847-565-4923

Mexico

CKD Mexico, S. de R.L. de C.V.
Cerrada la Noria No. 200 Int. A-01, Querétaro Park II,
Parque Industrial Querétaro, Santa Rosa Jáuregui,
Querétaro, C.P. 76220, México
Phone: +52-442-161-0624

Europe

CKD Europe B.V.
Beechavenue 125A, 1119 RB Schiphol-Rijk, The Netherlands
Phone: +31-(0)23-5541490

CKD Corporation Europe Branch
Beechavenue 125A, 1119 RB Schiphol-Rijk, The Netherlands
Phone: +31-(0)23-5541490

Italy

CKD Italia S.R.L.
Via di Fibianna 15, 50041 Calenzano (FI), Italy
Phone: +39-(0)55-882-5359 Fax: +39-(0)55-882-7376

●Specifications are subject to change without notice.