



Safety Precautions

Always read this section before use.

When designing equipment using electric actuators, the manufacturer is obligated to ensure that the safety of the mechanism and the electrically controlled system are secured.

It is important to select, use, handle and maintain CKD products appropriately to ensure their safe usage.

Observe warnings and precautions to ensure device safety.

Check that device safety is ensured and a safe device is manufactured.

WARNING

- 1** This product is designed and manufactured as a general industrial machine part. It must be handled by an operator having sufficient knowledge and experience in handling.
 - 2** Use the product within specifications range.
This product must be used within its stated specifications. It must not be modified or machined additionally. This product is intended for use as a device or part for general-purpose industrial machinery. It is not intended for use outdoors (except for outdoor type) or for use under the following conditions or environment.
(Note that this product can be used under the following conditions only when CKD is consulted prior to use and the customer consents to CKD product specifications. The customer must provide safety measures to avoid risks in the event of problems.)
 - 1** Use for special applications which require the safety, including nuclear energy, railways, aircrafts, marine vessels, vehicles, medicinal devices, devices or applications coming into contact with beverages or foodstuffs, amusement devices, emergency operations (cutoff circuits, opening etc.) circuits, press machines, brake circuits, or safety devices or applications.
 - 2** Use for applications where life or assets could be adversely affected and special safety measures are required.
 - 3** Observe organization standards and regulations, etc. related to the safety of device design.
 - 4** Never remove devices before confirming safety.
 - 1** Inspect and service on the machine and devices after confirming safety of the entire system related to this product.
 - 2** Note that there may be hot or charged sections even after operation is stopped.
 - 3** When inspecting or maintaining device, be sure to shut down the power supply of the equipment and the relevant power supply, using caution to avoid electric shock.
 - 5** Observe instruction manual and precautions attached the product surely to prevent accidents.
 - 1** The product could operate unexpectedly during teaching operation or trial operation. Be especially careful not to touch the actuator. If operating the product from a position where the shaft body cannot be seen, be sure to first confirm that the safety is secured even if the actuator moves.
 - 6** Observe precautions to prevent electric shock.
 - 1** Do not touch the heat sink, cement friction, or motor inside the controller.
These will heat up, and could cause burns. Wait an appropriate amount of time prior to performing inspections or other tasks. A high voltage is applied until the electrical load stored in the internal capacitors is discharged after the power is turned OFF. Do not touch for around three minutes after the power OFF.
 - 2** Make sure to turn the switch on the controller power supply source OFF, before maintenances and inspections.
There is a danger of high voltage electric shocks.
 - 3** Do not attach or remove connector, while the power is on. Otherwise, this may cause malfunction, failure, or electric shock.
 - 7** Install an overcurrent protector.
The wiring to the driver should be in accordance with JIS B 9960-1:2019 (IEC 60204-1:2016) Safety of Machinery - Electrical Equipment of Machines - Part 1: General Requirements. Install an overcurrent protector (a circuit breaker or circuit protector for wiring) on the main power, control power, and I/O power.

(Reference: JIS B 9960-1 7.2.1 General description)
If there is a possibility the circuit current may exceed the rated value of the component or the allowable current of the conductor, an overcurrent protection must be provided. The details of the ratings or set values to be selected shall be provided in 7.2.10.
 - 8** Observe precautions below to prevent accidents.
- The precautions are ranked as "DANGER", "WARNING" and "CAUTION" in this section.

 **DANGER:** When a dangerous situation may occur if handling is mistaken leading to fatal or serious injuries, and when there is a high degree of emergency to a warning.

 **WARNING:** When a dangerous situation may occur if handling is mistaken leading to fatal or serious injuries.

 **CAUTION:** When a dangerous situation may occur if handling is mistaken leading to minor injuries or physical damage.

Note that some items described as "CAUTION" may lead to serious results depending on the situation. Every item provides important information and must be observed.

Warranty

1 Warranty period

The product specified herein is warranted for one (1) year from the date of delivery to the location specified by the customer.

2 Warranty coverage

If the product specified herein fails for reasons attributable to CKD within the warranty period specified above, CKD will promptly provide a replacement for the faulty product or a part thereof or repair the faulty product at one of CKD's facilities free of charge.

However, following failures are excluded from this warranty:

- 1) Failure caused by handling or use of the product under conditions and in environments not conforming to those stated in the catalog, the Specifications, or the Instruction Manual.
- 2) Failure caused by use of the product exceeding its durability (cycles, distance, time, etc.) or caused by consumable parts.
- 3) Failure not caused by the product.
- 4) Failure caused by use not intended for the product.
- 5) Failure caused by modifications/alterations or repairs not carried out by CKD.
- 6) Failure caused by reasons unforeseen at the level of technology available at the time of delivery.
- 7) Failure caused by acts of nature and disasters beyond control of CKD.

The warranty stated herein covers only the delivered product itself. Any loss or damage induced by failure of the delivered product is excluded from this warranty.

Note: For details on the durability and consumable parts, contact your nearest CKD sales office.

3 Compatibility confirmation

The customer is responsible for confirming the compatibility of CKD products with the customer's systems, machines and equipment.

4 Range of service

The delivered product price does not include engineer dispatch service fees. Separate fees will be charged in the following cases.

- (1) Instruction of installation and adjustment, and presence on test operation
- (2) Maintenance and inspection, adjustment, and repair
- (3) Technical instructions and technical education (operation, program, wiring method, safety education, etc.)

Precautions for export

Products and related technologies in this catalog

Those of the products and related technologies in this catalog which are subject to US Export Administration Regulations

(EAR) are marked on the product page as "Product subject to the EAR (EAR99) or (EAR99 and 3A991)". For export or provision of products or related technologies subject to EAR regulations, we request that the US Export Administration Regulations (EAR) be observed appropriately.



Safety Precautions

Be sure to read this section before use.

Also refer to "Electric actuator, controller ECR, ECG Series (Catalog No.CC-1444A)".

IndividualCaution: Electric actuator FLSHSeries

Design/selection

⚠ WARNING

- The gripping force may decrease during a power outage or similar. Use a safe design that takes this into consideration. The gripping force may decrease during a power outage or similar, dislodging the workpiece, so be sure to install a safety mechanism to prevent injury or mechanical damage.

⚠ CAUTION

- When gripping long or large workpieces, stable gripping requires a grip on the center of gravity. Stability is a must when using larger or multiple workpieces as well.

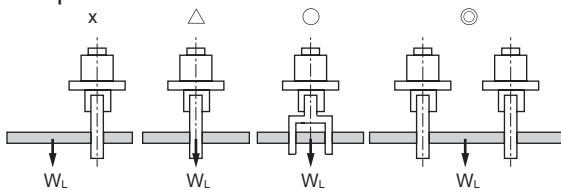

◎: Excellent, ○: Good, △: Conditional, x: NG

- The rubber cover is a consumable part. Replace if necessary.
- Select a model that has sufficient power to grip the workpiece weight.
- Select a model that has sufficient opening/closing width for the workpiece size. The gripping position may become unstable due to variation in the open/close width or the workpiece. When opening after gripping operation, increase the stroke by an amount corresponding to the backlash.

Mounting, installation and adjustment

⚠ CAUTION

- Do not move the cable leading out of the actuator. Fix the cable part. Furthermore, use cables with a bending radius of 40mm or more. (* Other than case removal)

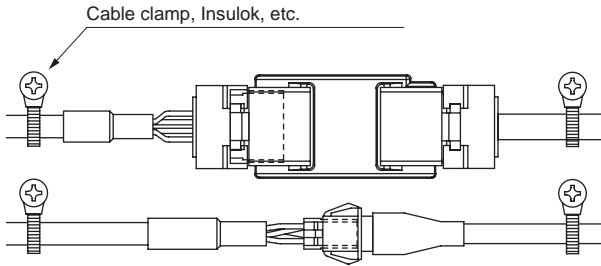

- Use cable for case removal with a bending radius of 31mm or more.
- Refer to the following section for body mounting.
- Front mounting

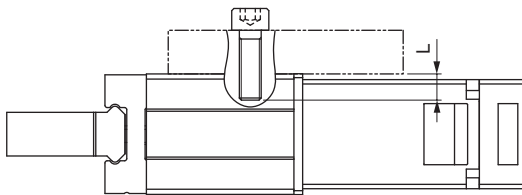

Item	Bolt used	Tightening torque (N·m)	Max. screw insertion depth L (mm)
FLSH-16	M 4 x 0.7	2.1	8
FLSH-20	M 5 x 0.8	4.3	8
FLSH-25	M 6 x 1.0	5.2	10

● Side mounting

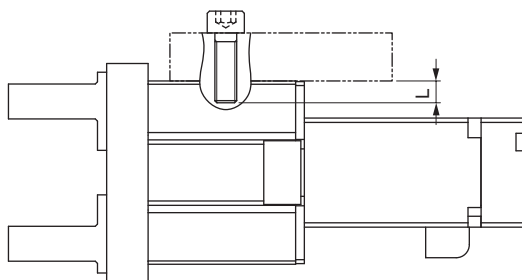

Item	Bolt used	Tightening torque (N·m)	Max. screw insertion depth L (mm)
FLSH-16	M 4 x 0.7	1.6	4.5
FLSH-20	M 5 x 0.8	3.3	8
FLSH-25	M 6 x 1.0	5.2	10

● Use of through hole

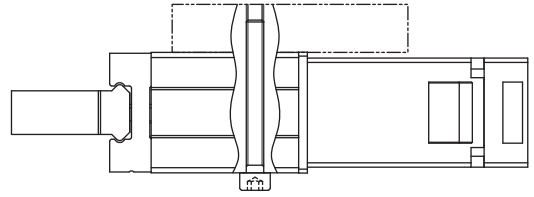

Item	Bolt used	Tightening torque (N·m)
FLSH-16	M 3 x 0.5	0.88
FLSH-20	M 4 x 0.7	2.1
FLSH-25	M 5 x 0.8	4.3

- To remove the workpiece when not energized, use the manual operation plate to open/close the finger, or remove the attachment and then remove the workpiece. Do not apply excessive force to the manual operation plate. Otherwise it could be damaged or malfunction. (Refer to page 21)
- Be sure not to apply an excessive load to the fingers and attachment when attaching and detaching or conveying workpieces. The linear guide rolling contact surface of the fingers may be scratched or dented, resulting in a malfunction.

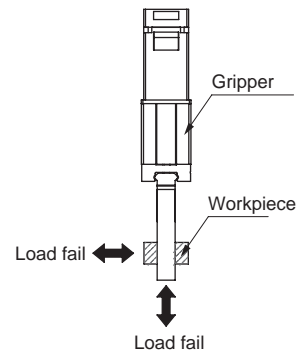

- Do not cause dents or scratches that may damage flatness or perpendicularity on the body mounting surface and finger.
- Do not retighten or disassemble, other than the screws used for fixing the body and finger. This could lead to malfunction.

● Attachment mounting method

When mounting the attachment to the finger, to prevent any effect on the gripper, support with a wrench, etc., when tightening so that the finger is not twisted.

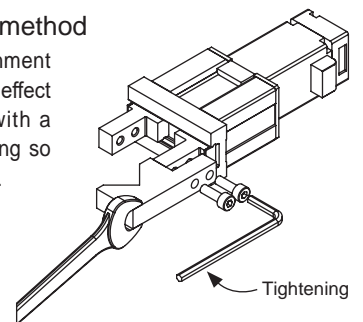

Item	Bolt used	Tightening torque (N·m)
FLSH-16	M 3 x 0.5	0.59
FLSH-20	M 4 x 0.7	1.4
FLSH-25	M 5 x 0.8	2.8

⚠ CAUTION

■ Repeatability

The repeatability here indicates the displacement of the finger in the case of repeated clamping and unclamping in the same conditions (gripper fixed, same attachment used: see below). Shock during opening and closing may lead to position misalignment of the workpiece and deterioration of repeatability. Note as well that attachment wear or insufficient rigidity may lead to deterioration of accuracy.

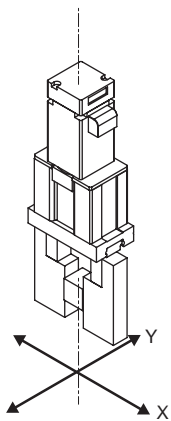

Conditions

- Attachment dimensions, shape, weight
- Attachment workpiece gripping position
- Clamp method, length
- Attachment and workpiece contact area resistance
- Fluctuation of gripping power, etc.

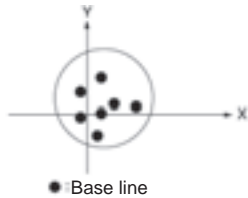

- The amount of backlash has no effect during pressing operation. Backlash may cause misalignment in the position of the finger during positioning operation, so be sure to take the amount of backlash into consideration when setting the position.
- When gripping during pressing operation, set the target position with some margin from the stop position. (Include the amount of backlash.)
- When gripping a workpiece, always use pressing operation. Do not allow the finger or attachment to strike the workpiece during positioning operation or within the positioning range. The feed screw may seize, leading to malfunction.
- Set the operating torque when releasing the grip to a value larger than the pressing operating torque. If the release torque is low, galling may prevent releasing.

- If the finger suffers galling due to operation setting abnormalities, use the manual operation plate to open/close the finger. However, do not apply excessive torque to the manual operation plate. Otherwise it could be damaged or malfunction.

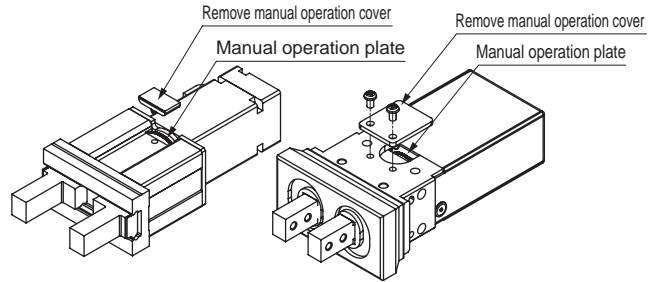

- This finger uses a finite orbit guide. Therefore, when inertia is applied due to travel or rotation, the steel ball moves closer, possibly increasing the sliding resistance or decreasing the accuracy. In this case, perform Full Stroke operation.
- Apply AFF grease (THK) to the guide rail surface after six months or when the number of operation times reaches one million, whichever comes first.