

**INSTRUCTION  
MANUAL****ELECTRIC ACTUATOR****KBZ Series****ROD TYPE****KBZ-3D****KBZ-4D****ACTUATOR INSTRUCTION  
MANUAL**

- Read this manual carefully and thoroughly before using this product.
- Pay extra attention to the instructions concerning safety.
- After reading this manual, keep it in a safe and convenient place.

# Discontinue

## Introduction

Before using the Electric Actuator KBZ series, read through and completely understand this instruction manual to assure correct use.

For general details on the Electric Actuator KBZ series, see the instruction manual (basic) provided separately.

## Cautions

1. This equipment comes under the industrial robot as prescribed in Article 36, Paragraph 31 of the Industrial Safety and Health Law of Japan. Before the use, therefore, be sure to read through and strictly observe the important notices stipulated in the technical guidelines relating to the safety standards for using the industrial robot, etc., pursuant to Article 28 of the same Law.
2. The contents of this manual are subject to change without prior notice to effect improvements.
3. All efforts have been made to assure the contents of this manual. If you have any questions, or find any mistakes, however, please contact CKD.
4. CKD will not be held responsible for any effects caused by using this equipment, regardless of Item 3 above.
5. This equipment does not have an explosion-proof structure. Take utmost care of the operating environment.

# Discontinue

## Table of Contents

	Page
Introduction	2
General Descriptions .....	1
Section 1 Safety .....	1
1.1 Safety Instructions .....	1
1.2 To Use the Equipment Safely .....	4
1.2.1 Safety Measures .....	4
1.2.2 Installation Precautions .....	4
1.2.3 Usage Precautions .....	5
1.3 Warranty .....	6
1.3.1 Warranty Period .....	6
1.3.2 Warranty coverage .....	6
1.3.3 Disclaimers .....	7
1.3.4 Notes .....	7
Section 2 List of Shipment .....	7
2.1 List of Shipment .....	7
Section 3 Axis (Actuator) Specifications .....	8
3.1 Type of Axis and Name of Each Part .....	8
3.2 Single Axis Specifications .....	9
Section 4 Installing Actuator (Axis) .....	12
4.1 Installing Actuator (Axis) .....	12
4.2 Setting Type of Robot .....	13
4.3 Setting Parameters .....	13
4.3.1 Parameter 1 Assigned by Type of Robot .....	13
4.3.2 Parameter 2 Assigned by Type of Robot .....	14
Section 5 Maintenance and Inspection .....	15
5.1 Cautions on Maintenance and Inspection .....	15
5.2 Inspection before Starting Operation .....	16
5.3 Regular Inspection .....	16
5.4 Adjusting Home Position and Changing Motor .....	17
5.5 Changing Home Position .....	19
5.6 Changing Motor Lead Wire Hole Direction .....	19
5.7 Lubricating Each Part .....	20
5.8 Maintenance of Other Parts .....	21

# Discontinue

5.9	Clamping Torque of Bolts and Nuts .....	21
Section 6	Spare Parts .....	21
6.1	Spare Parts .....	21

## General Descriptions

- This manual describes the axis code designation method, specifications and motor replacement procedures, etc., according to the type of axis.

## Section 1 Safety

### 1.1 Safety Instructions

- Before the installation, programming, operation, maintenance and inspection of the equipment, be sure to read through this manual so that you can use the Electric Actuator with safety.
- After you have read this manual, keep it nearby for future reference.

Be sure to strictly observe the following safety instructions to assure correct use of the Electric Actuator.

This manual contains the important information to prevent injury to the operators and persons nearby, to prevent damage to assets and to assure correct use of the equipment. Make sure that you have well understood the following details (indications and symbols) before reading this manual. Always observe the information that is noted.



This means that "incorrect handling will lead to fatalities or serious injuries."



This means that "incorrect handling" may lead to personal injuries or physical damage (i.e., damages to building, household goods, domestic animals and pets).

### Note

Briefly describes the points and notices for the operating procedures, and the points for using the equipment efficiently.

# Discontinue



## WARNING

- **Install the safety fences to prevent anyone from entering the working envelope of the robot.**

When the door is attached to the safety fence, the robot should be stopped at emergency at the same time that the door has opened.

- **Connect the EMERGENCY STOP pushbutton switch to the emergency stop input terminal of the controller and mount the same switch at an easy-to-operate place in an emergency.**

The EMERGENCY STOP switch must not be reset automatically and cannot be reset negligently by any person.

- **Wiring should be done safely and completely according to the Electrical Installations Technical Requirements and Interior Wiring Requirements of Japan.**

Incorrect wiring will result in an electric shock or a fire.

- **The equipment MUST NOT be repaired or modified without prior written permission from the manufacturer.**

Otherwise, an accident or damage will be caused.

- **Before the maintenance and inspection, be sure to turn off the controller main power switch. Take all necessary measures to prevent anyone other than the worker engaged in adjustment of the robot from negligently turning the power on. (Lock the switch and put a tag showing "DO NOT turn the power on.")**

**Also, DO NOT touch the controller interior three (3) minutes after the power is turned off.**

Otherwise, you may get an electric shock due to residual voltage of the capacitor.

- **DO NOT touch the internal parts of the controller immediately after the power is turned off.**

They are too hot and you may get burnt. Before performing inspection, take enough time to cool them off.

- **Take careful precautions when handling the stainless sheet.**

Otherwise, you may cut your finger by the end of the stainless sheet.

- **DO NOT pour water on the equipment interior or exterior, or drain water from it. Otherwise, you may get an electric shock, or the equipment will be damaged.**

When the equipment has contaminated, wipe it off with a hard squeezed cloth. DO NOT use a thinner, benzene or other organic solvent.

- **DO NOT put your finger or hand on the movable part.**

Otherwise, you may get injured.

- **When using the actuator in other than the horizontal state, be sure to select the actuator with brake.**

Otherwise, the movable part will drop at power OFF, and you will be injured.

- **As the equipment is heavy, make sure of its weight and gravity center position and disconnect the cables when carrying the equipment.**

Also, make sure that the movable parts are secured in place before carrying the equipment. Otherwise, the movable part will move and you will get injured.

# Discontinue

- **DO NOT use this equipment for the living body as a massaging machine.**  
Otherwise, you will be injured due to incorrect teaching or mis-operation.
- **This equipment is not completely sealed. During use, grease or wear of resin may scatter from the opening of the equipment.**  
When using this equipment for food and chemical applications, take appropriate measures against entry of them.
- **Enter the robot type and initialize the memory correctly.**  
Otherwise, the robot may move unexpectedly and you will be injured.
- **DO NOT use this equipment in an atmosphere of inflammable gas or an atmosphere inducing an explosion.**  
As this equipment is not explosion-proof, it may explode in the worst occasion.
- **DO NOT damage, break, process, forcibly bend, stretch, place a heavy object on or pinch the cables (power cable, controller cable).**  
Otherwise, an electric shock or a fire will be caused.
- **Should an abnormality such as smoke or nasty smell occur, turn the power off immediately and stop using the equipment.**  
If the equipment is used continuously, an electric shock or a fire will be caused.



## CAUTION

- **DO NOT place the equipment at a place where the ambient temperature exceeds 40°C, or where the temperature changes sharply, causing condensing, or where it is exposed to direct sunlight. DO NOT place it at a narrow place, either.**  
Otherwise, the ambient temperature rises due to heat generation in the controller itself or external device, which will result in malfunction or mis-operation of the equipment.
- **DO NOT use the equipment at a place where an impact or vibration is involved. Also, DO NOT use the equipment in an atmosphere where conductive dust, corrosive gas or oil mist generates.**  
Otherwise, a fire, electric shock, malfunction or mis-operation will be caused.
- **DO NOT exert external force which exceeds the maximum speed of the axis on the movable part.**  
Otherwise, the equipment may malfunction or operate incorrectly.
- **DO NOT use the equipment at a place where too much dust or dirt exists.**  
If the equipment is used at such a place, it may malfunction because this equipment is not dust-proof.
- **DO NOT use repair parts other than those designated by the manufacturer.**  
Otherwise, the equipment cannot be operated to its full capacity and will cause malfunction.
- **Mount the robot on a highly rigid frame.**  
If rigidity of the frame is not enough, vibration (or resonance) may be caused during the robot operation, adversely affecting the operation.

## 1.2 To Use the Equipment Safely

Before using the Electric Actuator KBZ Series, measures must be taken that meet the requirements below.

This equipment corresponds to an industrial robot as stipulated in Article 36, Item 31 of the Occupational Safety and Health Rules. In accordance with Article 28 of the Occupational Safety and Health Law, important information needed for “Selection”, “Installation”, “Operation”, “Periodic Inspection”, and “Training” is provided in “Technical Guidelines for Safety Standards in Operation and Other Use of the Industrial Robot”. Be sure to carefully read this information before using this equipment. A portion of this content is presented below.

### 1.2.1 Safety Measures

- (1) Provide a safety fence so that people do not easily enter the hazard area of the robot.

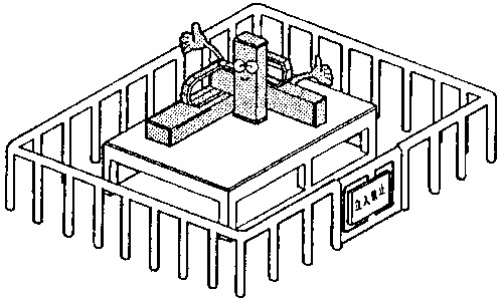

1. The fence must have sufficient strength to withstand the forces and other environmental conditions during work and must have a structure that cannot be easily adjusted, removed, climbed over, or otherwise circumvented.
2. The safety fence must not have tooth-shaped or sharp edges or other protrusions or hazardous parts.
3. The safety fence must be a lock type.
4. If installing a door or other access to the safety fence, an interlink must be provided that stops the robot when the door is opened.

- (2) In case of an emergency, emergency stop devices must be installed at locations easily accessible to the operator for enabling a quick stop of the robot.

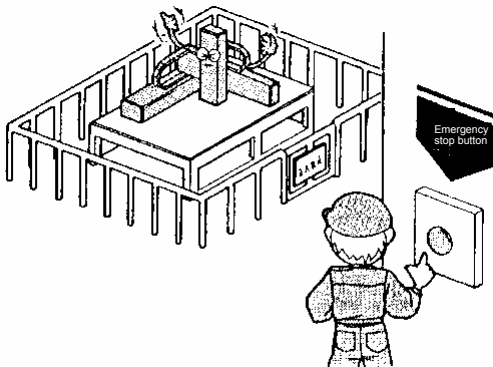

1. When an operator activates an emergency stop switch, the emergency stop function must be capable of bringing the robot to a complete stop quickly.
2. The emergency stop buttons must be red.
3. The emergency stop devices must be provided in locations where the operator can easily pull, press, touch, and intercepted rays.
4. Once the emergency stop function is activated, it cannot be reset automatically, and it should have a function unable to be reset unintentionally by the operator.

- (3) To ensure safety, never attempt to modify the robot unit or the controller.

### 1.2.2 Installation Precautions

Pay attention to the following points in the installation of the robot.

- (1) The robot must be installed in a location that can provide the required work space for robot teaching and maintenance and inspection.
- (2) The robot controller, other controllers, and stationary operation panels must be installed outside the movement range and at locations where the operator can oversee robot operation.
- (3) The pressure gauges, oil pressure gauges, and other instrumentation must be installed in easily visible locations.
- (4) If the electrical wires or hydraulic and pneumatic piping are subject to potential damage, covers or other protection must be provided.
- (5) To enable activation of the emergency stop device in the event of an emergency, switches for the emergency stop device must be installed at locations besides the operation panel as necessary.



# Discontinue

## 1.2.3 Usage Precautions

Pay attention to the following points in usage of the robot.

[Work within the movement range]

### (1) Work rules

Rules must be established for the items below, and work must be performed in accordance with these rules.

1. Startup procedures, switch operating procedures, and other robot operation methods and procedures required in the work
2. Robot unit speed when performing the teaching operation
3. Signaling method when performing work by two or more operators
4. Measures that must be taken by the operator based on the specific problem that occurs
5. After robot operation is stopped, such as by activation of an emergency stop device, measures required for restarting the robot for checking that the problem situation was resolved and for checking safety
6. In addition to the items above, the following measures required for preventing hazards due to unintended operation of the robot and malfunction of the robot
  - Indicators on the operation panel
  - Measures for ensuring safety of operators within the movement range
  - Position and stance for performing operation
  - Measures for preventing malfunctions due to noise
  - Signaling method with operators of related equipment
  - Types of problems and identification methods
7. Suitable work rules must be provided based on the robot type, installation location, work content, and other details.
8. In the drafting of the work rules, efforts must be made to solicit opinions from the involved operators, manufacturer technicians, occupational safety consultants, and other advisors.

### (2) Indicators on the operation panel

During work, safety measures must be implemented to prevent unintended operation of the startup switches, selector switches, and other controls by persons besides the operator engaged in the relevant work, such as by displaying easy-to-understand information on the relevant switches to indicate that work is in progress or by locking the operation panel cover.

### (3) Measures for ensuring safety of operators within the movement range

When performing work within the movement range, implement one of the measures below or an equivalent measure to enable immediate stopping of the robot in the event of a problem.

1. A supervisor with the required authority must be stationed at a location outside the movable area where robot operation can be observed, and this person must be assigned the principal task of supervision and perform the following actions.
  - Immediate activation of emergency stop device in the event of a problem
  - Preventing people besides operators engaged in work from entering into the movement range
2. The operator performing the work within the movement range must carry a switch for the emergency stop device.
3. Work must be performed using a portable operation panel with a structure for turning the power on and off and turning the hydraulic and pneumatic supplies on and off.

# Discontinue

- (4) Inspection before starting teaching and other work  
Before starting teaching and other work, inspect the following points, and if any problems are found, immediately fix the problem and take other necessary measures.
  1. Damage in the external power supply coating or covering (Turn off the power before performing this inspection.)
  2. Problems in operation of the robot unit
  3. Functions of braking devices and emergency stop devices
  4. Air pressure or oil leaks from piping
- (5) Measures for cleaning of work tools  
When painting nozzles and other work tools attached to the robot unit must be cleaned, it is preferable that the cleaning and related work be performed automatically for minimizing the number of times that operators enter into the movement range.
- (6) Release of residual pressure  
When disassembling the pneumatic system components, replacing parts, or performing other work, the residual pressure in the driving cylinder must be released beforehand.
- (7) Confirmation operation  
To the greatest extent possible, the confirmation operation must be performed without entering into the movable range.
- (8) Brightness  
The required brightness must be maintained for enabling work to be performed safely.

[Performing of automatic operation]

- (1) Measures at startup  
Before starting the robot, be sure to check the points below, and decide on a predetermined startup signal that is issued to the relevant operators.
  1. Make sure that no one is inside the movement range.
  2. The portable operation panel, tools, and other devices are at their proper locations.
  3. The robot and relevant devices do not indicate any problems or abnormalities.
- (2) Measures for automatic operation and for occurrence of problems
  1. After the robot is started, a check must be made that an indicator is displayed showing that automatic operation is in progress.
  2. If an operator must enter into the movement range for taking emergency action or other reason when a problem has occurred in the robot or related devices, measures must be provided for preventing operation of the robot by people besides the operator performing the emergency action such as by stopping robot operation using activation of an emergency stop device and carrying a safety plug and indicating that operation is in progress on the startup switch.

## 1.3 Warranty

### 1.3.1 Warranty Period

The warranty period of the product is one of the periods below, whichever is reached first.

- (1) 12 months after CKD factory shipping
- (2) 4000 hours of operation

### 1.3.2 Warranty coverage

- (1) This warranty covers this product. The scope of the warranty applies to the specifications and functions that were stipulated in the specifications, catalog, instruction manual, and other documentation of this product. CKD will not be liable for any secondary or incidental damage as a result of breakdowns of this product.

# Discontinue

- (2) During the warranty period of this product, CKD will repair free of charge only breakdowns that occur for operation and usage performed in accordance with the instruction manuals provided with the product. Repairs will entail the return of the product to the factory. However, if service staff are sent or other measures taken based on the customer's specific circumstances, CKD reserves the right to invoice separately for transportation and lodging costs and for costs arising not directly related to product repair.

## 1.3.3 Disclaimers

The cases below are outside the scope of the warranty.

- (1) Breakdowns and damage due to failure to use in accordance with the instruction manual or failure to pay attention during operation
- (2) Nonconformity due to the passage of time or usage wear (such as natural fading of paint and degradation of consumable parts\*<sup>1</sup>)
- (3) Nonconformity in sensory conditions (such as the occurrence of noises not affecting functionality)
- (4) When modifications or disassembly was performed without the authorization of CKD
- (5) Breakdowns or damage due to inadequate maintenance or inspection or improper repairs
- (6) Breakdowns and damage due to natural disasters, fires, or other external causes
- (7) Internal data, such as programs and points, and other that was created or modified by the customer
- (8) When this product was purchased in Japan and taken outside the country

\*1: Consumable parts refer to the maintenance and replacement parts (spare parts) shown in the instruction manual of each product and the parts that must be replaced periodically (such as backup batteries).

## 1.3.4 Notes

- (1) CKD cannot guarantee basic performance of this product when it is used under conditions outside the product specifications.
- (2) CKD is not liable for any accidents, damage, or breakdowns that occur as a result of failing to follow the warning and caution information provided in this instruction manual.
- (3) The warning and caution information and other descriptions provided in this manual do not cover every possible situation imaginable.
- (4) The numerical values presented in the technical documentation were derived from calculations and are intended to serve as a reference for durability and do not constitute a warranty of any kind. Differences will arise based on the specific usage conditions.

## Section 2 List of Shipment

### 2.1 List of Shipment

The actuator to be shipped normally consists of the following parts.

- (1) Actuator
- (2) Square nuts
  - The following quantities of square nut are attached for each axis (i.e., actuator) above. They may not be attached for some axes.

Axis	Square nut
KBZ-3D-ST-C12*-**	-
KBZ-4D-ST-C12*-**	M3 square nut; six (6) pcs.

- (3) Actuator Instruction Manual (This manual)

# Discontinue

## Section 3 Axis (Actuator) Specifications

### 3.1 Type of Axis and Name of Each Part

- Type of axis  
The type of axis is as shown below.

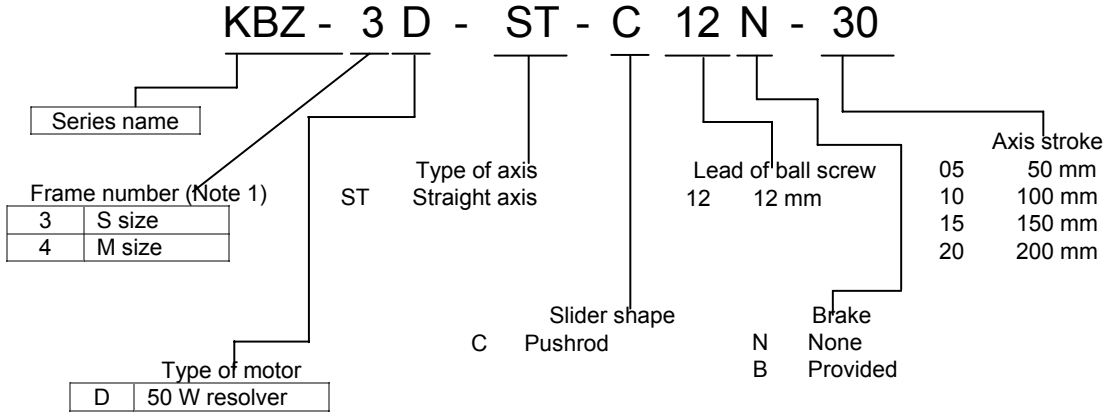

(Note 1) Frame width: Small size 35 mm, Medium size 45 mm

- Name of each part

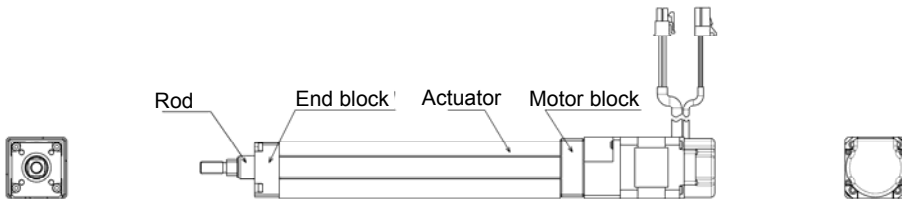
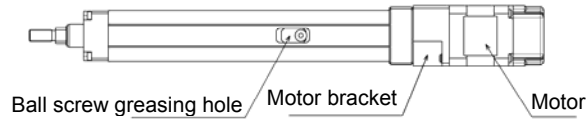

## 3.2 Single Axis Specifications

(1) Specifications

- Pushrod type

Type of axis: KBZ-3D-ST-C12□□-□□

Motor	50 W absolute AC servo motor	
Drive system	Use of ball screw	
	Diameter 8 mm	Lead 12 mm
Maximum payload mass	Horizontal (Note 1)	Vertical
	3 kg	(1.5 kg)
Rated thrust	49 N	
Maximum thrust	147 N	
Maximum speed	600 mm/s	
Repeatability	±0.02 mm	
Resolution	0.01 mm	
Service life (Note 2)	5,000 km	

Type of axis: KBZ-4D-ST-C12□□-□□

Motor	50 W absolute AC servo motor	
Drive system	Use of ball screw	
	Diameter 8 mm	Lead 12 mm
Maximum payload mass	Horizontal (Note 1)	Vertical
	5.2 kg	(2.2 kg)
Rated thrust	49 N	
Maximum thrust	147 N	
Maximum speed	600 mm/s	
Repeatability	±0.02 mm	
Resolution	0.01 mm	
Service life (Note 2)	5,000 km	

Note 1: This series can exert load only in the axial direction.  
The horizontal payload mass is the value when no radial load is imposed on the rod by using the linear guide also.

Note 2: This value is obtainable under the maximum payload mass at the rated speed and acceleration/deceleration of 0.15 sec.

(2) Axis dimensions  
[KBZ-3D-ST-C12] (50 W motor specifications)

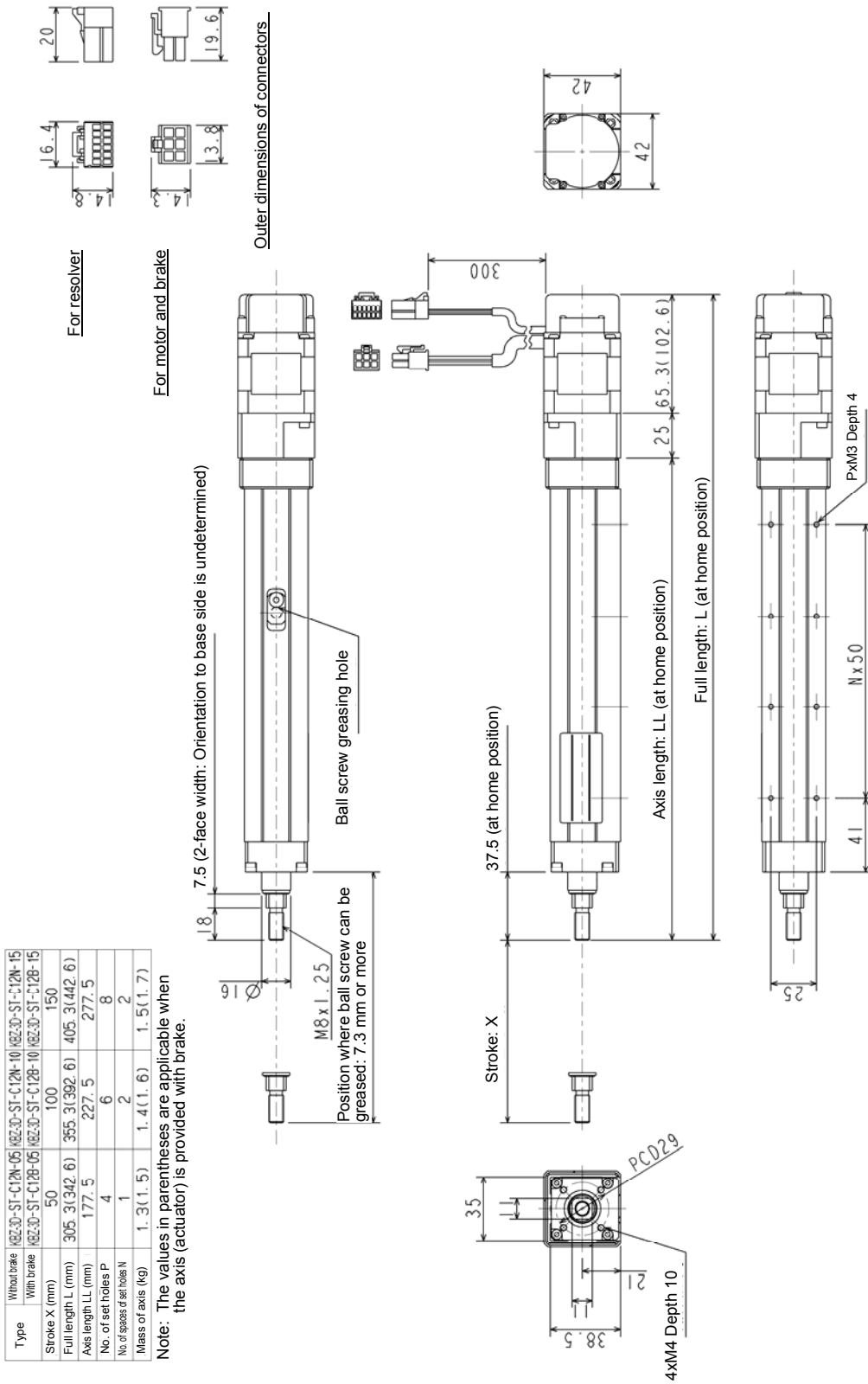

[KBZ-4D-ST-C12] (50 W motor specifications)

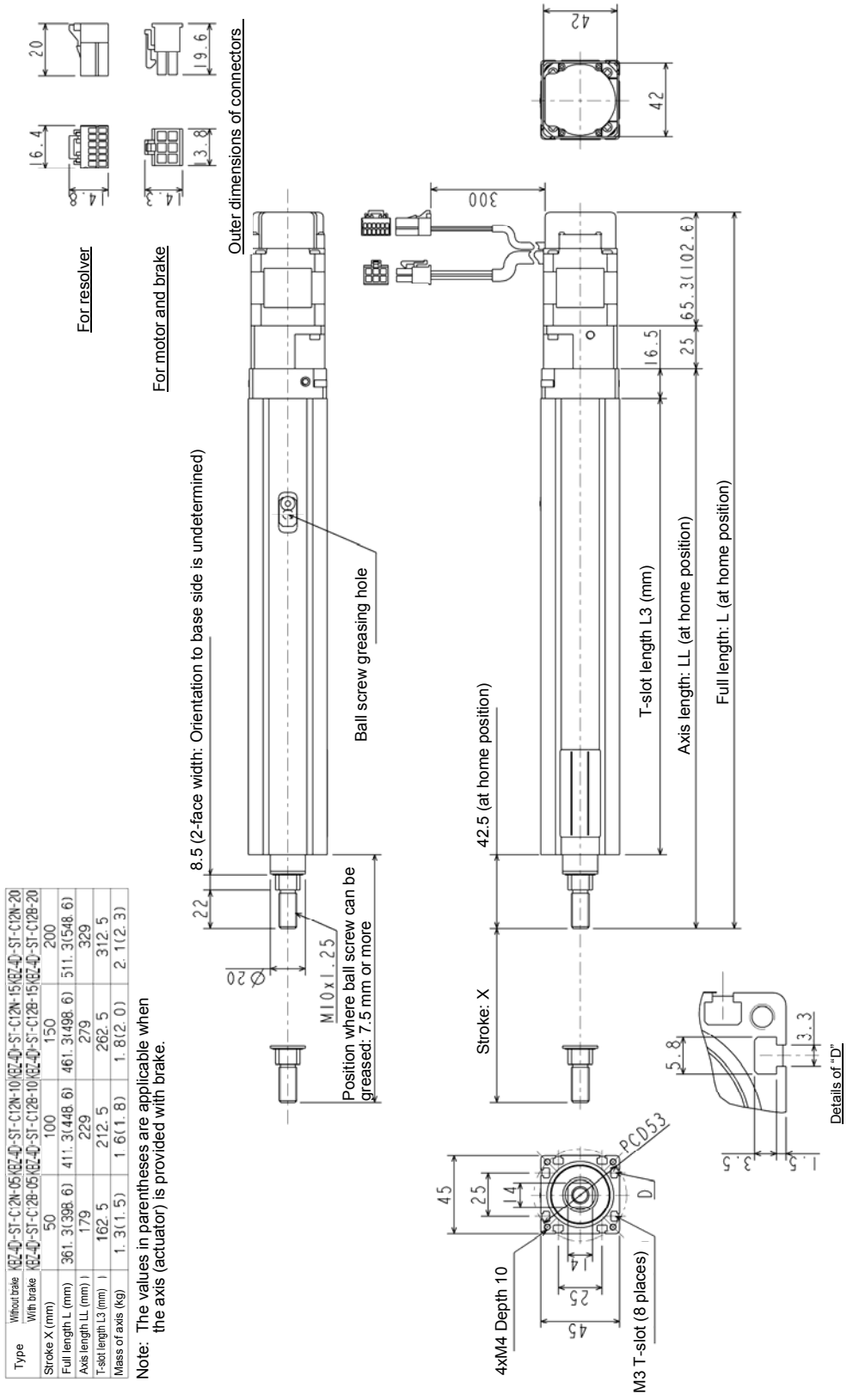

## Section 4 Installing Actuator (Axis)

### 4.1 Installing Actuator (Axis)

- This section describes the basic installation of the actuator (axis) and basic mounting of the peripheral parts.
- Install the actuator, referring to this section. If the actuator is installed incorrectly, the robot cannot be operated to its full capacity and its service life will shorten drastically.



Cautions on installation

- Environment of installation place
  - (1) The actuator should be installed under the following environment.
    - Temperature: 0°C ~ 40°C
    - Humidity: Location at 30% to 80% RH with no freezing or condensation
    - Place where dust or oil mist does not exist.
    - Place where inflammable or corrosive gas does not exist.
    - Place where electric noise is not involved.
    - Place where vacuum or radioactivity does not exist.
  - (2) This actuator is not designed to be explosion-proof. Avoid using it at a heavily contaminated place. Take careful precautions on the operating environment.
- Cautions on installation
  - (1) DO NOT drop the actuator or hit it against any object during transport.
  - (2) Provide an ample space for the maintenance and inspection beforehand.
  - (3) Install the controller at a place where the standard cable can reach from the actuator.
  - (4) At the time of installation:
    - Install the actuator on a leveled set base.
    - The set base shall have such a length that allows mounting of the frame only.
    - The set base must be made of steel plate with a thickness of 9 mm or more and having a machining surface with the specified flatness (KBZ-5D: 0.05 mm/200 mm, KBZ-7D: 0.06 mm/200 mm) or less or a flatness providing an equivalent accuracy. Mount the actuator on this base, then correct a bend or twist of the actuator frame and reinforce the same frame.
- Installation  
Install the actuator on the set base, using the taps and T-slots on the bottom surface of the actuator. Use screws with a suitable length to ensure that the screw ends do not interfere with the internal components.



## 4.2 Setting Type of Robot

The type of the robot refers to a six (6)-digit numerical number specified according to the type of the axis (actuator).

Once the type of the robot has been specified, various parameter values for the axis (actuator) to be used are set automatically. For details on the input procedure, see Para. 2.7.6 of the KCA-01-M05 Instruction Manual (Basic).

[Robot Type for KBZ-3D/KBZ-4D Pushrod Type]

(1) When the actuator serves as the rod type axis (normal use):

	Lead of ball screw (mm)	Axis code designation	Type of robot
KBZ-3D	12	KBZ-3D-ST-C12□-□□	700320
KBZ-4D	12	KBZ-4D-ST- C12□-□□	700420

## 4.3 Setting Parameters

This equipment is provided with Parameter 1 and Parameter 2 according to the counts of use. The contents of each group of parameters and relationship between the type of robot and each group of parameters are shown below.

When the type of the robot is specified, parameter values marked "○" under the column of auto setting are set automatically.

For details, see Chapter 3 of the KCA-01-M05 Instruction Manual (Basic).

### 4.3.1 Parameter 1 Assigned by Type of Robot

These are the parameters used very frequently.

- Straight axis (slider type axis)

Auto setting	Parameter	Type of robot	700320	700420
			Lead: 12	Lead: 12
	Soft limit value (plus)		0000.00	0000.00
	Soft limit value (minus)		0000.00	0000.00
○	Servo gain	P (Position)	20	20
		V (Speed)	50	70
○	Home point offset value		0000.00	0000.00
	Jog speed	L (low speed)	10	10
		H (High speed)	50	50
	Jog travel distance		0.01	0.01

# Discontinue

## 4.3.2 Parameter 2 Assigned by Type of Robot

Compared to Parameter 1, this includes axis-related parameters that are changed less frequently. After these parameters are changed, be sure to turn the control power and drive power off and then on again. The parameters will not be enabled unless the control power and drive power are turned off.

- Straight axis (slider type axis)

Auto setting	Parameter	Type of robot	700320	700420
			Lead: 12	Lead: 12
	Axis display		X1	X1
<input type="radio"/>	In-position data		0.05	0.05
<input type="radio"/>	Overflow data		5120	5120
<input type="radio"/>	Motor revolving direction		1	1
<input type="radio"/>	Maximum speed data		600	600
<input type="radio"/>	Home return speed data	L (Low speed)	2	2
		M (Mid speed)	20	20
		H (High speed)	100	100
<input type="radio"/>	Home return method		2	2
<input type="radio"/>	Logic of home point sensor		1	1
	High-speed home return position		20	20
<input type="radio"/>	Lead		12.000	12.000
<input type="radio"/>	No. of divisions of encoder		2048	2048
	Multiplier		4	4
	Sensor type		0	0

## Section 5 Maintenance and Inspection

### 5.1 Cautions on Maintenance and Inspection

- (1) Cautions on maintenance and inspection  
When performing inspection and maintenance, observe the following matters.
  1. Maintenance and inspection of the robot should be performed only by a qualified person well versed in the knowledge and having experiences. Unless such a person is present, consult with the manufacturer to take necessary measures such as having the relevant work done by the manufacturer or having the customer's responsible persons trained for the work by the manufacturer.
  2. Use an appropriate illumination.
  3. Put a tag showing "Under inspection (or maintenance)" on the start switch, etc., equipped on the stationary operation panel.  
When entering the fence or premises, lock the power switch which is turned off to completely cut off the power. If the safety plug is attached to the entry of the fence or premises, carry it with you.
  4. When you have to enter the fence or premises for inspection or maintenance of the control circuit, be sure to shut off the drive power source beforehand.
  5. When you have to operate the industrial robot for inspection or maintenance inside the fence or premises, it is recommended to take the measures prescribed below.
    - The work should be performed by two (2) persons. That is, when one person executes the work, the other person keeps a watch.
    - The robot speed is desirably such that can avoid contact with the worker should the robot move unexpectedly. Determine the appropriate speed according to the work to be done.
    - During the work, take careful precautions on the robot motions. If the robot has not moved just as you intended, immediately press the EMERGENCY STOP pushbutton switch.
  6. Before disassembling the air pressure gage, etc., or replacing the part, release the residual pressure from the cylinder.
  7. When disassembling the hydraulic or pneumatic circuit or replacing the part, take utmost care not to allow adhesion or entry of contaminant.
- (2) Measures to be taken at the end of inspection and maintenance
  1. Persons in charge of inspection and maintenance should return all tools to the predetermined place after the work has finished.
  2. After the maintenance, be sure to test-run the equipment for confirmation. In principle, the test-run for confirmation should be performed from outside the fence or premises.
  3. After the work in Item 2 above has been performed, persons responsible for inspection and maintenance should report their manager that the inspection or maintenance has completed.

## 5.2 Inspection before Starting Operation

- (1) Before starting the robot operation, perform check on the following matters.
  1. Function of control unit.
  2. Function of emergency stop switch.
  3. Function of robot interlock with equipment for preventing contact.
  4. Function of robot interlock with related equipment.
  5. Damage of external power supply, piping, etc.
  6. Abnormality of supply voltage, supply hydraulic pressure and supply pressure.
  7. Nonconformity of operation.
  8. Abnormal noise and abnormal vibration.
  9. Condition of equipment for preventing contact.
- (2) Execute the inspection outside the working envelope, where possible.

## 5.3 Regular Inspection

Determine the inspection standard including the check items, method, criteria for evaluation and time of execution for the following items, considering the robot installation place, frequency of use and durability of parts, then execute the inspection according to the same standard.

1. Looseness of main parts.
2. Lubrication state of movable parts and other abnormality of movable parts.
3. Abnormality of power transmission parts.
4. Abnormality of hydraulic and pneumatic circuits.
5. Abnormality of electric circuit.
6. Abnormality of function detecting a motion error.
7. Abnormality of resolver.
8. Abnormality of servo system.

[Check points of controller]

9. Make sure that the supply voltage to the controller falls under the predetermined range (i.e., rated voltage  $\pm 10\%$ ).
10. Check for the air vent holes on the controller, and remove contaminant if any left on them.
11. Check for the controller cable (running from the controller to the actuator) and make sure that all screws, etc., are tightened completely.
12. Make sure that the controller set screws, etc., are tightened completely.
13. Check each connector (power connector, motor connector, sensor connector, 232C connector, I/O connector), and make sure that they have no looseness, gaps, or other abnormalities.

## 5.4 Adjusting Home Position and Changing Motor

Adjust the home position in the following manner.

- (1) Turn the power off.
- (2) Remove the hexagon socket cap screw (M5) of the motor bracket.  
Move the rod forward or backward by hand to align the position of the coupling clamp screw (hexagon socket head cap screw (M2.5)) securing the motor shaft with the hole position where the hexagon socket cap screw was just removed. (Use a narrow rod or other object to check the hexagonal screw of the coupling in the motor block.) Loosen the coupling clamp screw that is securing the motor shaft.  
If the coupling screw is in a location that cannot be loosened in an axis with brake configuration, turn on the power, and use the jog operation to move the slider to a position where the tool will be inserted. (For details, see 2.9.9 in the KCA-01-M05 Instruction Manual (Basic).)  
Also, you can use the controller brake release switch (SW1) to release the brake, and move the slider to a position where work is possible. (For details, see 2.6-(2) in the KCA-01-M05 Instruction Manual (Basic).)  
Before loosening the coupling screw, turn off the servo, and turn off the power.

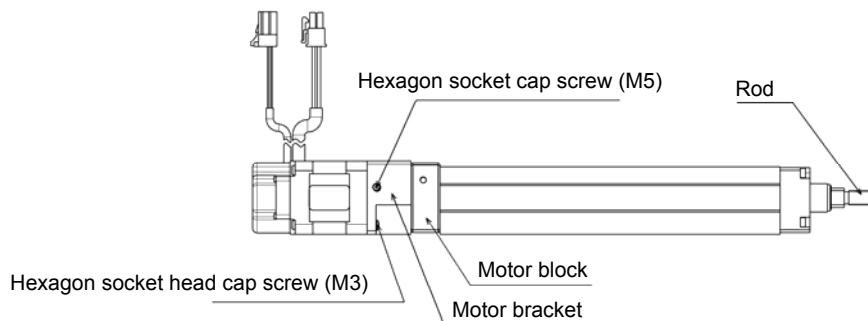

Fig. 5.4-1

- (3) Remove the hexagon socket cap screw (M3) securing the motor, and then remove the motor from the axis unit.
- (4) Connect the axis and controller, and turn on the power. For details on the connection procedure, see 2.8.6 in the KCA-01-M05 Instruction Manual (Basic).
- (5) Set the Parameter 1 servo gain (position and speed) to "0". For details on the setting procedure, see 3.3.3 and 3.3.4 in the KCA-01-M05 Instruction Manual (Basic).
- (6) Set the home position return method of Parameter 2 to "3". For details on the setting procedure, see 3.4.9 in the KCA-01-M05 Instruction Manual (Basic).
- (7) Execute the home return. Wait until the motor stops.

# Discontinue

- (8) Align the distance from the rod end to the body frame with the home position. When aligning, check whether coupling screws (M2.5) can be tightened from the hole of the hexagon socket cap screw (M5) that was just removed for loosening the coupling screws in the motor bracket. If it can be tightened, perform the operation in step (11).

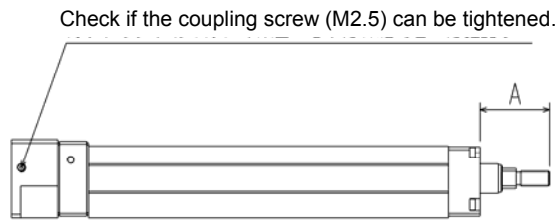

Fig. 5.4-2

Type of axis	A
KBZ-3D-ST-C***-**	37.5
KBZ-4D-ST-C***-**	42.5

- (9) If the coupling screw (M2.5) is not at a position where it can be tightened, remove the hexagon socket cap screw (M5), and remove the motor bracket.

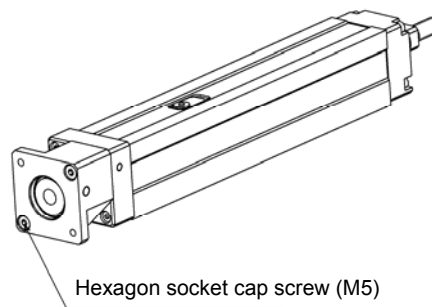

Fig. 5.4-3

- (10) Loosen the screw (M2) of the coupling that secures the joint shaft, adjust the coupling to a position where the coupling screw (M2.5) can be tightened from the M5 hole of the motor bracket, and after tightening the coupling bolt (M2) (tightening torque is 0.4 N·m) (see 5.9), reassemble the motor bracket.

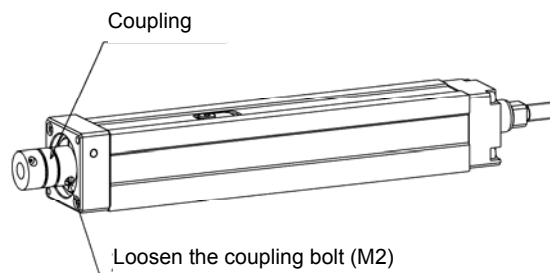

Fig. 5.4-4

# Discontinue

- (11) Turn off the controller power, mount the motor as originally set, then clamp it with the coupling screw (M2.5). (Clamping torque 1.0 N·m)  
(See Para. 5.9.)



Before tightening the coupling clamp screw, be sure to turn off the controller power.  
DO NOT shift the motor shaft and coupling from the stopped positions.

- (12) Turn the power on again, return the servo gain values (position and speed) to the previous values, then specify "2" for the home return method of Parameter 2.
- (13) After the power is turned off, then on again, execute the home return and make sure that the rod is located as shown in Fig. Table 5.1.
- (14) After the confirmation is completed, use the hexagonal socket cap screw (M5) to cover the work hole.

## 5.5 Changing Home Position

- (1) Specify "1" for the motor revolving direction of Parameter 2. For details on the connection procedure, see 3.4.9 in the KCA-01-M05 Instruction Manual (Basic).
- (2) Adjust the home position. The adjustment procedure is identical to 5.4. Align the distance from the rod end to the body frame with the modified home position.



Fig. 5.5-1

Type of axis	B
KBZ-3D-ST-C***-**	37.5
KBZ-4D-ST-C***-**	42.5

## 5.6 Changing Motor Lead Wire Hole Direction

When changing the direction of the motor lead wire hole, observe the same procedures as in Para. 5.4 above.

Before mounting the motor, rotate it toward the desired direction.

## 5.7 Lubricating Each Part

[Lubricating procedures]

1. Extend the rod further from the position that allows greasing of the ball screw as shown in Table 5.3. Thus, the ball screw can be greased directly from the ball screw greasing hole. (If the rod is contracted from the position that allows greasing of the ball screw, the internal part will stand in the way and the ball screw cannot be greased accordingly.)
2. Turn off the drive power.
3. Remove the cover of the ball screw greasing hole on the actuator.

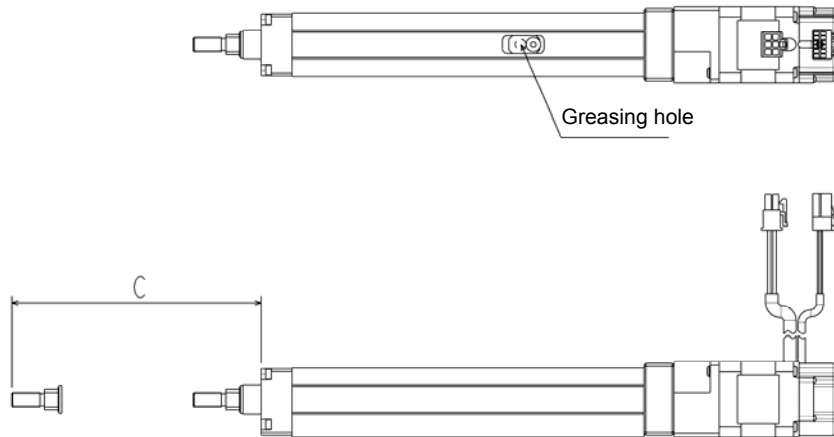

Fig. 5.7-1

Type of axis	C
KBZ-3D-ST-C12*-**	73 mm or more
KBZ-4D-ST-C12*-**	75 mm or more

4. Lubricate according to the following table and figures above.

Lubricating point	Type of oil (Maker)	Lubricating intervals	Lubricating volume
Ball screw	Alvania grease S2 (Shell Oil)	Every three (3) months	Fill the oil of 1 cc per 100 mm stroke from the ball screw greasing hole.

5. Wipe away any oozing oil and tarnished oil.
6. Attach the cover of the ball screw greasing hole.



## 5.8 Maintenance of Other Parts

- If a problem arises in the axis unit, such as a failure of a ball screw, please contact our sales agent in your territory.  
NEVER attempt to disassemble or repair components yourself.
- Generally, repair of ball screws requires replacing of the axis unit. Be aware that components inside the equipment and the axis unit combination with other equipment must be replaced.

## 5.9 Clamping Torque of Bolts and Nuts

Part name	Nominal size of screw	Clamping torque (N·m)	Remarks
Hexagon socket head cap screw	M2.5	1.0	For coupling (ball screw side)
Hexagon socket head cap screw	M2	0.4	For coupling (motor side)
Hexagon socket head cap screw	M5	5.88	For securing the motor bracket
Hexagon socket head cap screw	M3	0.98	For securing the motor

## Section 6 Spare Parts

### 6.1 Spare Parts

If the robot went wrong, but no repair part is available at hand, it cannot be repaired even if a trouble has been found at an early stage. To avoid this, it is recommended that each customer keep the spare parts at hand.

No.	Part name	Description
1	AC servo motor (Resolver)	Used for all KBZ series models (50 W)
2	AC servo motor with brake (Resolver)	Used for all KBZ series models (50 W)