

Drain separator FXW Outdoor-use Series

INSTRUCTION MANUAL

SM-A58844-A



- Read this Instruction Manual before using the product.
- Read the safety notes carefully.
- Keep this Instruction Manual in a safe and convenient place for future reference.

PREFACE

Thank you for purchasing CKD's **"FXW Outdoor-use Series" Drain separator**.

This Instruction Manual contains basic matters such as installation and usage instructions in order to ensure optimal performance of the product. Please read this Instruction Manual thoroughly and use the product properly.

Keep this Instruction Manual in a safe place and be careful not to lose it.

Product specifications and appearances presented in this Instruction Manual are subject to change without notice.

- The product is intended for users who have basic knowledge about materials, piping, electricity, and mechanisms of pneumatic components. CKD shall not be responsible for accidents caused by persons who selected or used the product without knowledge or sufficient training.
- Since there are a wide variety of customer applications, it is impossible for CKD to be aware of all of them. Depending on the application or usage, the product may not be able to exercise its full performance or an accident may occur due to fluid, piping, or other conditions. It is the responsibility of the customer to check the product specifications and decide how the product shall be used in accordance with the application and usage.

SAFETY INFORMATION

When designing and manufacturing any device incorporating the product, the manufacturer has an obligation to ensure that the device is safe. To that end, make sure that the safety of the machine mechanism of the device, the pneumatic or water control circuit, and the electric system that controls such mechanism is ensured.

To ensure the safety of device design and control, observe organization standards, relevant laws and regulations, which include the following:

ISO 4414, JIS B 8370, JFPS 2008 (the latest edition of each standard), the High Pressure Gas Safety Act, the Industrial Safety and Health Act, other safety rules, organization standards, relevant laws and regulations



In order to use our products safely, it is important to select, use, handle, and maintain the products properly.

Observe the warnings and precautions described in this Instruction Manual to ensure device safety.

Although various safety measures have been adopted in the product, customer's improper handling may lead to an accident. To avoid this:

**Thoroughly read and understand this Instruction Manual
before using the product.**

To explicitly indicate the severity and likelihood of a potential harm or damage, precautions are classified into three categories: "DANGER", "WARNING", and "CAUTION".

 DANGER	Indicates an imminent hazard. Improper handling will cause death or serious injury to people.
 WARNING	Indicates a potential hazard. Improper handling may cause death or serious injury to people.
 CAUTION	Indicates a potential hazard. Improper handling may cause injury to people or damage to property.

Precautions classified as "CAUTION" may still lead to serious results depending on the situation. All precautions are equally important and must be observed.

Other general precautions and tips on using the product are indicated by the following icon.

	Indicates general precautions and tips on using the product.
---	--

Precautions on Product Use

WARNING

The product must be handled by a qualified person who has extensive knowledge and experience.

The product is designed and manufactured as a device or part for general industrial machinery.

Use the product within the specifications.

The product must not be used beyond its specifications. Also, the product must not be modified and additional work on the product must not be performed.

The product is intended for use in devices or parts for general industrial machinery. It is not intended for use outdoors (Except for outdoor specification products) or in the conditions or environment listed below.

- In applications for nuclear power, railroad system, aviation, ship, vehicle, medical equipment, and equipment that directly touches beverage or food.
- For special applications that require safety including amusement equipment, emergency shut-off circuit, press machine, brake circuit, and safety measures.
- For applications where life or properties may be adversely affected, and special safety measures are required.

(Exception is made if the customer consults with CKD prior to use and understands the specifications of the product. However, even in that case, safety measures must be taken to avoid danger in case of a possible failure.)

Do not handle the product or remove pipes and devices until confirming safety.

- Inspect and service the machine and devices after confirming the safety of the entire system. Also, turn off the energy source (air supply or water supply) and power to the relevant facility. Release compressed air and fluid from the system and use extreme care to avoid water or electric leakage.
- Since there may be hot or live parts even after operation has stopped, use extreme care when handling the product or removing pipes and devices.
- When starting or restarting a machine or device that incorporates pneumatic components, make sure that a safety measure (such as a pop-out prevention mechanism) is in place and system safety is secured.

CONTENTS

- PREFACE..... i**
- SAFETY INFORMATION ii**
 - Precautions on Product Use..... iii
- CONTENTS..... iv**
- 1. PRODUCT OVERVIEW 1**
 - 1.1 Model Number Indication..... 1
 - 1.1.1 Single item..... 1
 - 1.1.2 Consumable and replacement parts 2
 - 1.2 Specifications..... 3
 - 1.2.1 Specifications 3
 - 1.2.2 Option weight..... 3
 - 1.3 Dimensions 4
 - 1.4 Internal Structure 5
- 2. INSTALLATION 6**
 - 2.1 Environment..... 6
 - 2.2 Unpacking 7
 - 2.3 Mounting 7
 - 2.4 Piping..... 7
- 3. USAGE..... 11**
- 4. AINTENANCE AND INSPECTION..... 12**
 - 4.1 Daily Inspection..... 12
 - 4.2 Periodic Inspection..... 12
 - 4.3 How to Discharge Drainage..... 13
 - 4.4 How to Perform Maintenance 13
- 5. TROUBLESHOOTING..... 14**
 - 5.1 Problems, Causes, and Solutions 14
- 6. WARRANTY PROVISIONS..... 15**
 - 6.1 Warranty Conditions 15
 - 6.2 Warranty Period 15

1. PRODUCT OVERVIEW

1.1 Model Number Indication

1.1.1 Single item

		A Model No.		
		FXW1004	FXW1011	FXW1037
Code	Description			
B Port size				
8	1/4	●	●	
10	3/8	●	●	
15	1/2		●	
20	3/4			●
25	1			●
C Port thread *1, *3				
Blank	Rc thread (pressure unit: MPa temperature display unit: °C)	●	●	●
N	NPT thread (pressure unit: psi temperature display unit: °F)	●	●	●
G	G thread (pressure unit: bar temperature display unit: °C)	●	●	●
D Option *4				
Drain discharge *5	Blank	Drain outlet Rc1/8	*2	●
	C	With manual cock		●
	F	Auto-drain with manual override (NO: Exhaust when not pressurized)		●
	F1	Auto-drain with manual override (NC: No exhaust when not pressurized)		●
guarantee period	Blank	1 year after delivery		●
	G	3 years after delivery *6 *7 (with inspection certificate, inspection guidelines, traceability system diagram)		●
Flow Direction	Blank	Standard flow (left → right)		●
	X1	Reverse flow (right → left)		●
E Attachment				
Blank	Not included	●	●	●
BW	C-bracket	●	●	●

⚠ Precautions for model No. selection

- *1: G and NPT threads are available for IN, OUT and drain outlet of auto-drain.
- *2: "N" or "G" piping thread cannot be selected when the optional drain discharge is "Blank".
- *3: In compliance with the Measurement Act, the psi display cannot be used in Japan.
- *4: Select options for the drainage, warranty period and flow direction items. When selecting options for several items, list options in order from the top.
- *5: Refer to "Pneumatic, Vacuum, and Auxiliary Components (Catalog No.CB-024SA)" for the auto-drain use conditions.
- *6: The warranty period of option G is 3 years from the date of delivery or 1 year from initial use.
- *7: For option G, the specifications and drawings must be agreed upon.

1.1.2 Consumable and replacement parts

■ Bowl assembly

	FXW1004	FXW1011	FXW1037
Metal bowl assembly with manual cock	FW3000-W-BOWL-M	FW4000-W-BOWL-M	FW4000-W-BOWL-M
Metal bowl assembly with Rc1/8 female thread	FXW1004-W-BOWL-M	FXW1011-W-BOWL-M	FXW1011-W-BOWL-M
Metal bowl assembly with NO auto-drain	FW3000-W-BOWL-FM	FW4000-W-BOWL-FM	FXW1037-W-BOWL-FFM
Metal bowl assembly with NC auto-drain	MW3000-W-BOWL-F1M	MW4000-W-BOWL-F1M	FXW1037-W-BOWL-FF1M

1.2 Specifications

1.2.1 Specifications

Item	FXW1004	FXW1011	FXW1037
Working fluid	Compressed air		
Working pressure MPa	0.1~1.0 Note 3		
Proof pressure MPa	1.5		
Fluid temperature °C	-20 to +60(no freezing)		
Ambient temperature °C	-20 to +60		
Water separation efficiency %	99 Note 2		
Max. processing flow rate Note 1 L/min(ANR)	550	1800	6100
Port size Rc, NPT, G	1/4, 3/8	1/4, 3/8, 1/2	3/4, 1
Product weight kg	0.3	0.5	1.2

Note 1: At inlet pressure 0.7 MPa.

Note 2: Water separation efficiency during processing flow rate.

(Evaporated water droplets (water vapor) cannot be separated)

Note 3: In the case of "F" with auto-drain, the min. working pressure of auto-drain is 0.1MPa.

Air is purged with initial drainage until pressure reaches 0.1MPa.

Note 4: In the case of "F1" with auto-drain, the min. working pressure of auto-drain is 0.15 MPa.

Note 5: In the case of with auto-drain, fluid temperature and ambient temperature are 5 to +60°C.

1.2.2 Option weight

Unit :kg

Code	Drain discharge		
	C	F	F1
FXW1004	0	0.02	0.02
FXW1011	0	0.02	0.02
FXW1037	0	0.02	0.02

*Add to the weight of the standard accessories.

1.3 Dimensions

● FXW1004-W

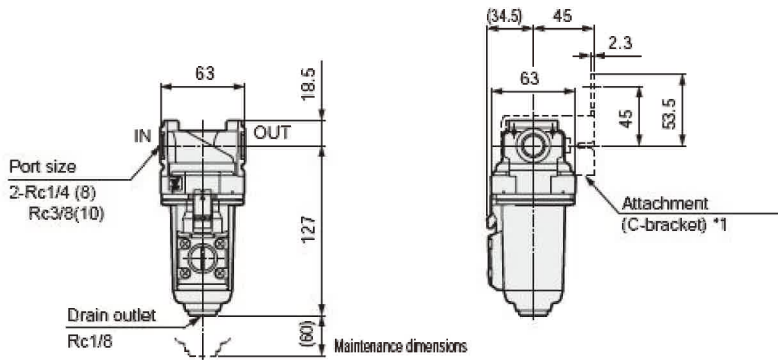

*1: Bracket is an included option.

- Optional dimensions
Manual drain cock (C)

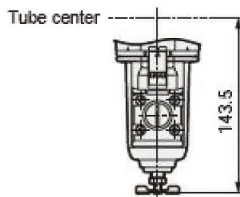

- Optional dimensions
With auto-drain (F, F1)

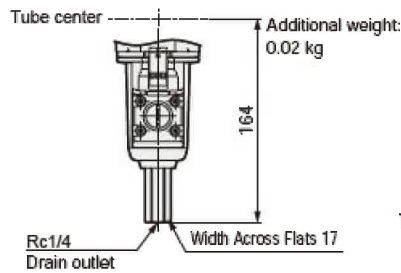

- Attachment
C-bracket (-BW)
Part model No.: B320

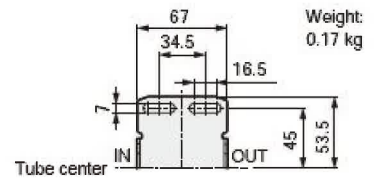

● FXW1011-W

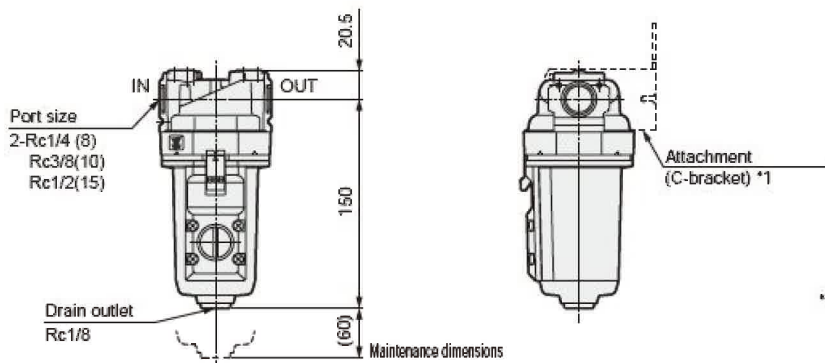

*1: Bracket is an included option.

- Optional dimensions
Manual drain cock (C)

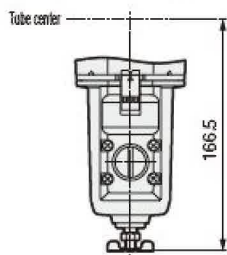

- Optional dimensions
With auto-drain (F, F1)

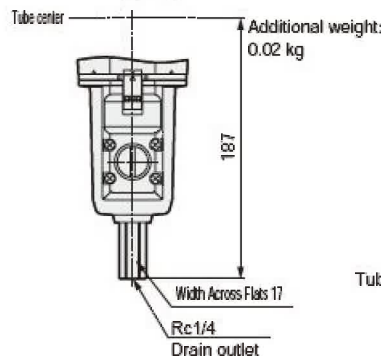

- Attachment
C-bracket (-BW)
Part model No.: B420

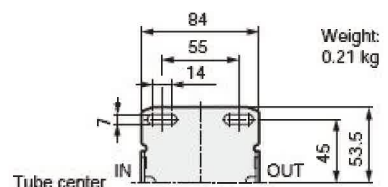

● FXW1037-W

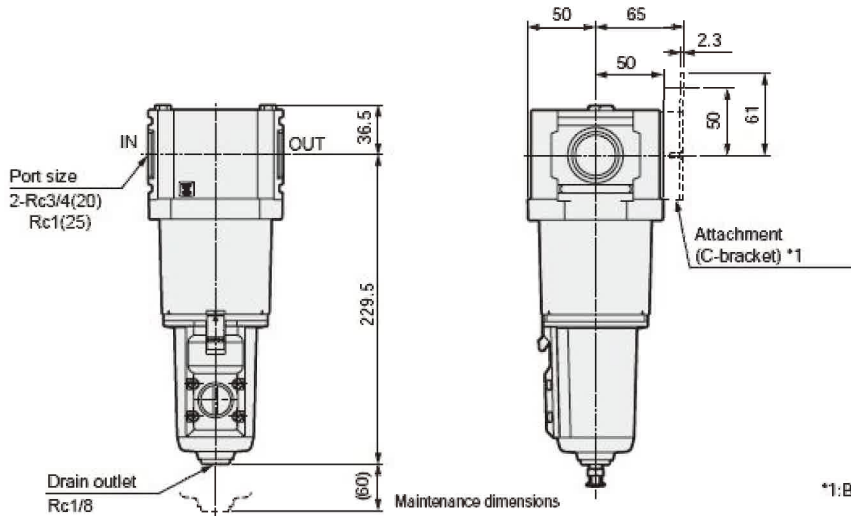

*1: Bracket is an included option.

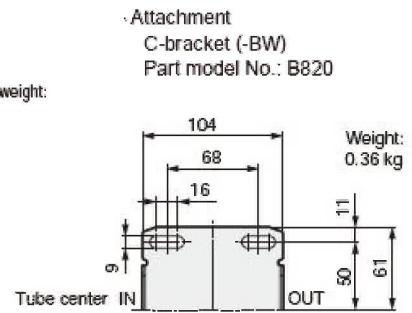
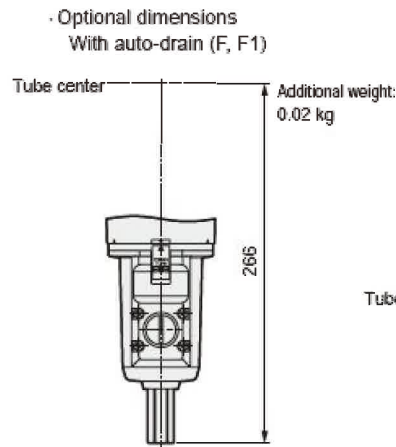
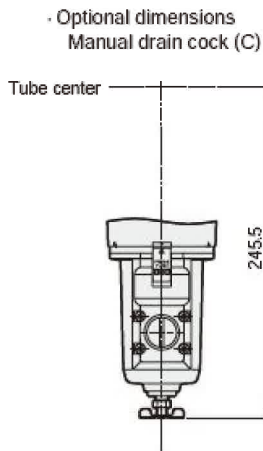

1.4 Internal Structure

● FXW1004/FXW1011 ● FXW1037

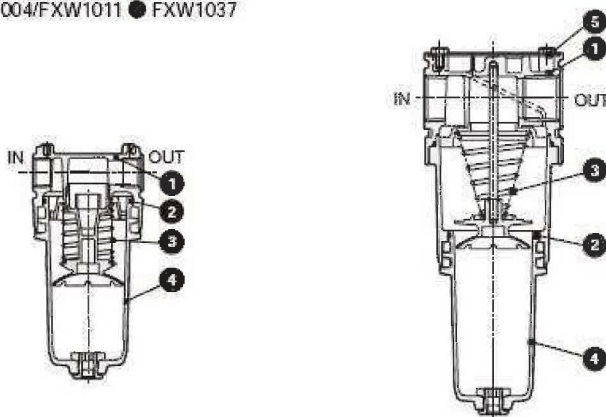

No.	Part name	Material
1	Body	Aluminum alloy die-casting
2	O-ring	Special nitrile rubber
3	Spring	Stainless steel
4	Metal bowl assembly	Aluminum alloy die-casting, copper alloy, Zinc alloy die-casting, nitrile rubber
5	Plate cover	Aluminum

2. INSTALLATION

2.1 Environment

CAUTION

Observe the following precautions regarding the ambient environment.

- Avoid installing the product where it is subject to vibrations and shocks.

Make sure that substances such as chlorine do not become mixed with the compressed air when using a water lubricated type compressor circuit.

Do not use the product in an environment where:

- Ambient temperature is outside the range of -20°C to +60°C (In the case of with auto-drain, outside the range of 5°C to +60°C)
- Air can freeze
- Water drop or cutting oil can splash onto the product
- Condensation may occur due to high humidity and temperature change
- Sea breeze or seawater can splash onto the product
- Atmosphere contains corrosive gas, fluids, or chemicals
- Atmosphere contains a lot of dust
- Atmosphere contains spatter
- It is exposed to direct sunlight, rain, wind, or water
- There is a heat source in the surrounding area and heat is radiated
- Ozone is produced
- There is vibration • impact

2.2 Unpacking

⚠ CAUTION

Do not open the packing of the product until just before piping.
Foreign matters may enter the product and cause a failure or malfunction.

- Check that the model number ordered and the model number indicated on the product are the same.
- Check the exterior of the product for any damage.

2.3 Mounting

■ C-type bracket (if selected in the model number)

Attach the C-type bracket to the product as shown in the figure below before piping.

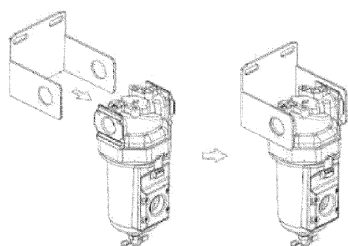

Align the convex portion of the C-type bracket with the concave portion of the product and push in.

2.4 Piping

⚠ WARNING

Do not apply pipe loads or torque to the body and the pipes.

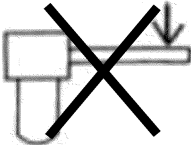

Do not support the product at only one end as illustrated in the figure below since this may apply excessive force and lead to damage.

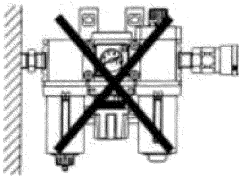

<Piping load torque>

Series	FXW1004-W	FXW1011-W	FXW1037-W
Max. torque (N·m)	50	50	100

 **CAUTION****Fully flush and clean the pipes before use.**

Residual dust or foreign matter in a pipe may cause operation fault.

Connect the pipes correctly according to the direction of flow by checking the direction of the arrow.**Prevent foreign matters from entering the pipes while piping and connecting the fitting.**

Be careful not to allow cutting chips from the piping screw and seal material from entering the pipes while piping and connecting the fitting.

Residual dust or foreign matter in a pipe may cause lower performance of the product.

Tighten the pipes with the appropriate tightening torque.**Do not subject the body and the pipes to a bending moment that is due to pipe loads.****Follow the conditions below for the drain piping of the automatic drain.**

To prevent operation faults, use pipes with an inside diameter of $\varnothing 5.7$ or more and a length of 5 m or less for the section of pipes for discharging the drainage and avoid riser piping.

Avoid piping that applies lateral loads to the bowl. Secure the hexagon side of the cock and screw the fitting into the Rc1/4 internal thread.

■ Pipe cleaning

Before piping, blow air into the pipes to clean the interior and to remove cutting chips and foreign matters.

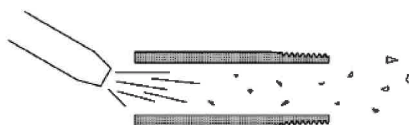

■ Seal material

Apply a seal tape or seal material to the screw threads leaving two or more threads at the pipe end uncovered or uncoated. If the pipe end is fully covered or coated, a shred of seal tape or residue of seal material may enter inside of the pipes or device and cause a failure.

When using a seal tape, wind it around the screw threads in the direction opposite from the screw threads and press it down with your fingers to attach it firmly.
 When using a liquid seal material, be careful not to apply it to resin parts. The resin parts can become damaged and this may lead to a failure or malfunction.
 Also, do not apply seal material to the internal threads.

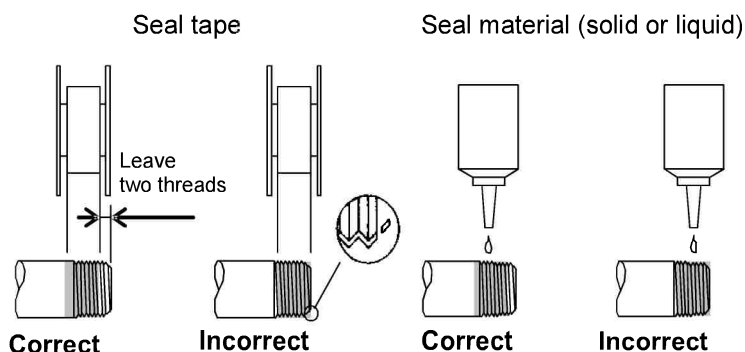

■ Pipe screwing torque

Do not apply excessive torque to the body and the pipes when piping.

Series	FXW1004-W	FXW1011-W	FXW1037-W
Max. torque (N·m)	30	30	70

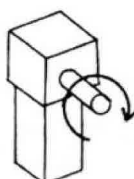

■ Drain piping for automatic drain

Secure the hexagon part of the cock and screw the fitting into the internal threads of the drain port. When using a metal bowl with automatic drain, drainage cannot be manually discharged if a tightening joint is used for the drain piping.

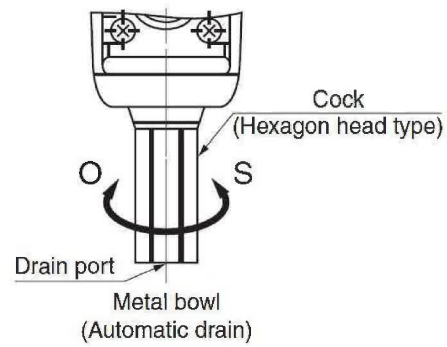

3. USAGE

WARNING

Use the product within the specifications.

Do not use the product for medical purposes or in any equipment or circuit that concerns human life.

The product is designed for industrial use.

CAUTION

Check the working circuit and the working fluid.

If fluids containing solids or fluids not in the specifications flow into the product, operation faults may occur. Attach a filter to the primary side of the product to prevent solids from entering.

Conditions of use for the automatic drain

<NO type automatic drain (discharges drainage when pressure is not applied): "F">

- Use a compressor with a capacity of 0.75 kW {90 l/min (ANR)} or more.
- Set the pressure to 0.1 MPa or more. (Air is purged with initial drainage until pressure reaches 0.1 MPa.)

<NC type automatic drain (does not discharge drainage when pressure is not applied): "F1">

- Use a compressor (a compressor with a capacity of 0.75 kW or less can be used).
- Set the pressure to 0.15 MPa or more.

4. AINTENANCE AND INSPECTION

⚠ WARNING

Stop supplying the pressure and make sure that there is no residual pressure before maintenance.

Discharge drainage from the drain separator so that it does not accumulate beyond the upper limit.

If drainage flows into the secondary side, operation faults may occur in the device.

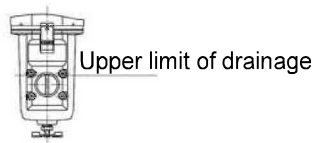

Metal bowl (C type)

Before removing the bowl assembly, stop supplying the compressed air, release the pressure from the bowl, and check that there is no residual pressure in the bowl.

⚠ CAUTION

Thoroughly read and understand the Instruction Manual supplied with the product before use and maintenance.

Do not disassemble or modify the product.

Perform periodic maintenance once every 6 to 12 months.

Replace consumable parts (metal bowl assembly, O ring) every year.

Although this oil product is specified for outdoor use, it is not guaranteed to be corrosion resistant (resist rusting and color change.)

4.1 Daily Inspection

- Thoroughly read and understand this Instruction Manual before maintenance and inspection.
- Check that the product operates properly before starting use.

4.2 Periodic Inspection

- In order to use the product under optimum conditions, perform a periodic inspection every six months.
- It is recommended to check that there is no leakage from the pipes.

4.3 How to Discharge Drainage

■ Discharging drainage (filter and filter regulator)

Metal bowl

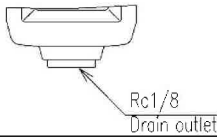

There is Rc1 / 8 screw on the drain outlet.

Metal bowl with automatic drain

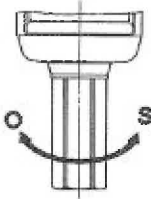

Drainage is discharged automatically when it is accumulated or can be discharged manually. It is operated in the same way as the plastic bowl. Drainage cannot be manually discharged if a tightening joint is used for the drain piping.

Manual discharge metal bowl

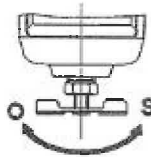

To discharge drainage, turn the cock in the O-direction, and to stop discharging, turn the cock in the S-direction.

4.4 How to Perform Maintenance

■ Removing the metal bowl

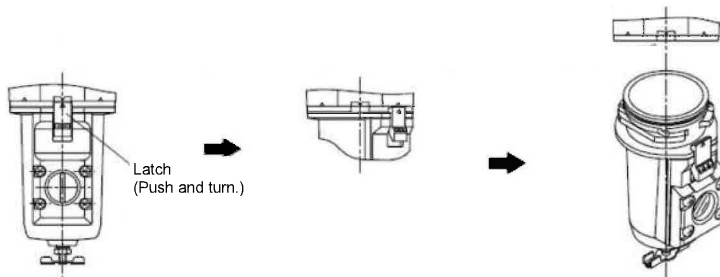

5. TROUBLESHOOTING

5.1 Problems, Causes, and Solutions

If the product does not operate as intended, check the table below for a possible solution.

Problem	Cause	Solution
Drainage occurs immediately after startup.	Drainage exceeds upper limit.	Discharge the drainage. (Refer to "4.3 How to Discharge Drainage".)
	Maximum processing flow rate is exceeded.	Replace with a model suitable for the working flow rate.
Drainage does not discharge when drain cock is opened.	Drain port is clogged with foreign matters.	Stop supplying the compressed air, remove the bowl assembly, and clean the inside of the bowl. If the problem persists after cleaning, replace the bowl assembly.
Automatic drain does not automatically discharge drainage. Air leaks from drain port.	Automatic drain is damaged, or drain port is clogged with foreign matters.	
Air leaks from where bowl is mounted.	There are scratches or foreign matters on O-ring for bowl sealing.	Stop supplying the compressed air, remove the bowl assembly, and clean or replace the O-ring.
	Bowl is damaged.	Stop supplying the compressed air, remove the bowl assembly, and replace the bowl assembly.

If you have any other questions or concerns, contact your nearest CKD sales office or distributor.

6. WARRANTY PROVISIONS

6.1 Warranty Conditions

■ Warranty coverage

If the product specified herein fails for reasons attributable to CKD within the warranty period specified below, CKD will promptly provide a replacement for the faulty product or a part thereof or repair the faulty product at one of CKD's facilities free of charge.

However, following failures are excluded from this warranty:

- Failure caused by handling or use of the product under conditions and in environments not conforming to those stated in the catalog, the Specifications, or this Instruction Manual.
- Failure caused by incorrect use such as careless handling or improper management.
- Failure not caused by the product.
- Failure caused by use not intended for the product.
- Failure caused by modifications/alterations or repairs not carried out by CKD.
- Failure that could have been avoided if the customer's machinery or device, into which the product is incorporated, had functions and structures generally provided in the industry.
- Failure caused by reasons unforeseen at the level of technology available at the time of delivery.
- Failure caused by acts of nature and disasters beyond control of CKD.

The warranty stated herein covers only the delivered product itself. Any loss or damage induced by failure of the delivered product is excluded from this warranty.

■ Confirmation of product compatibility

It is the responsibility of the customer to confirm compatibility of the product with any system, machinery, or device used by the customer.

■ Others

The terms and conditions of this warranty stipulate basic matters.

When the terms and conditions of the warranty described in individual specification drawings or the Specifications are different from those of this warranty, the specification drawings or the Specifications shall have a higher priority.

6.2 Warranty Period

The product is warranted for one (1) year from the date of delivery to the location specified by the customer.