

Vacuum ejector unit which is lightweight and compact in appearance and has a high-cycle vacuum system

VSX Series

- Nozzle diameter: $\varnothing 0.5$, $\varnothing 0.7$, $\varnothing 1.0$



Features

- A lightweight, compact vacuum unit that meets market needs.
- Available vacuum generating valves include normally closed and energy-saving self-hold types. Both valves attain the best possible response time, realizing high-cycle vacuum systems.
- Vacuum unit VSX fixing methods include direct mount, fixable from the side with screws, etc., and DIN rail mount for mounting on a DIN rail. Select the mounting method according to the application.
- Vacuum pressure switches include those with digital display for good visibility and those with an inexpensive analog output only type. A 2-point switch output and analog output are available for the vacuum pressure switch with LED display. Select according to various applications and cost. In addition, wiring layout can be done easily using a connector system.
- Nozzle diameter is 05 ($\varnothing 0.5$), 07 ($\varnothing 0.7$) 3 types of , 10 ($\varnothing 1.0$) are standardized.

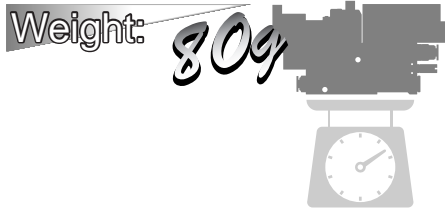

Note: The above weight is the value of vacuum ejector unit, common exhaust type and type with vacuum pressure switch and LED display.

- The manifold piping specifications are such that up to 10 stations can be attached.

Application of Ejector system compatible type

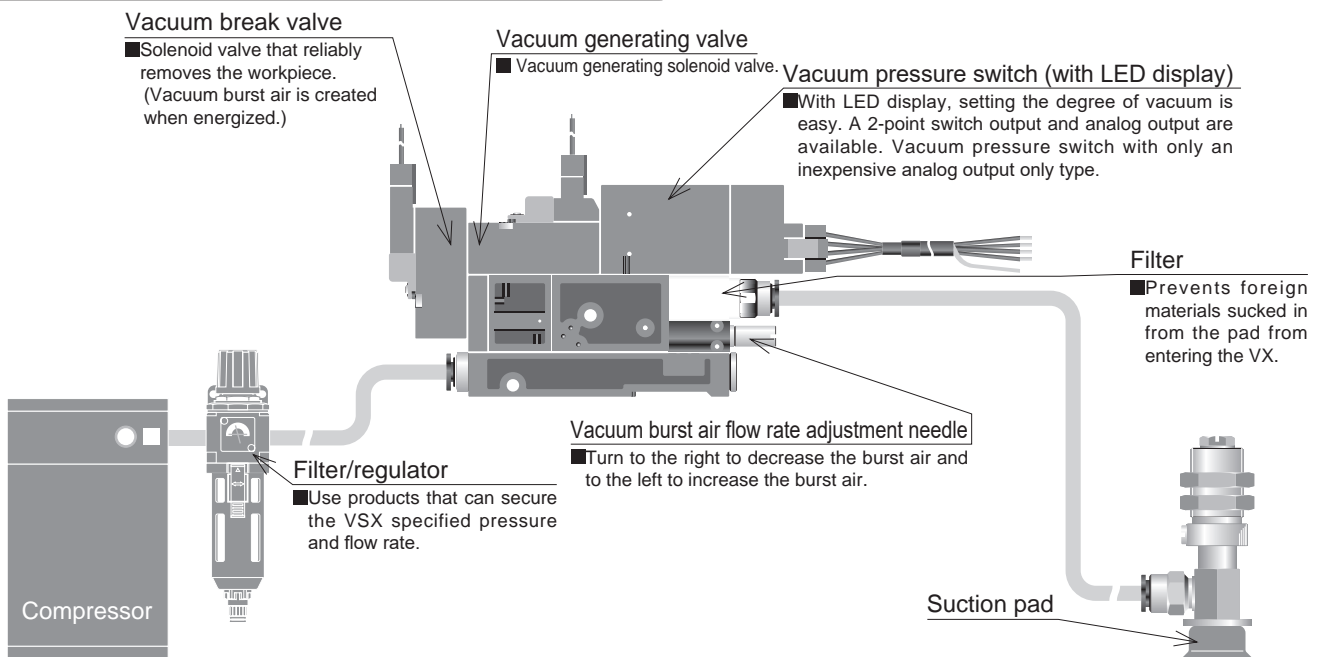

Specifications

Descriptions	VSX
Working fluid	Air
Working pressure MPa	0.3 to 0.7
Operating ambient temperature °C	5 to 50

Ejector characteristics

Model No.		Nozzle diameter (mm)	Rated supply pressure (MPa)	Achieved vacuum pressure (-kPa)	Intake flow rate (ℓ/min (ANR))	Air consumption rate (ℓ/min (ANR))			
VSX-H05...	Atmospheric release	0.5	0.5	90.4	7	11.5	Ejector system		
	Common exhaust								
VSX-L05...	Atmospheric release		0.35	90.4	3	8			
	Common exhaust								
VSX-H07...	Atmospheric release		0.7	0.5	93.1	13		23	VSX
	Common exhaust								
VSX-L07...S	Atmospheric release	66.5		24					
VSX-L07...J	Common exhaust						22		
VSX-E07...	Atmospheric release	0.35		90.4	10.5	17			
	Common exhaust								
VSX-H10...S	Atmospheric release	1.0	0.5	93.1	24	46	VSG		
VSX-H10...J	Common exhaust							20	
VSX-L10...S	Atmospheric release		66.5	26					
VSX-E10...S	Atmospheric release							0.35	90.4
VSX-E10...J	Common exhaust		19						

Note : Values in table are representative values. Suction flow rate differs with the vacuum piping conditions (vacuum port size, pipe length).

Valve specifications

● Pilot valve

Descriptions	Vacuum generating valve		Vacuum break valve		
Valve and operation	Direct acting poppet valve				VSK VSKM
Rated voltage V	24 DC	100 AC	24 DC	100 AC	VSKM
Allowable voltage fluctuation range V	24 DC ±10%	100 AC ±10%	24 DC ±10%	100 AC ±10%	VSKM
Surge protective circuit	Varistor	Bridge diode	Varistor	Bridge diode	VSKM
Power consumption	1.2 W (with LED)	1.5 VA (with LED)	1.2 W (with LED)	1.5 VA (with LED)	VSKM
Manual override	Non-locking push				VSN VSNM
Operation display	At coil excitation operation: Red LED lights				VSN VSNM
Connection	Connector: 500 mm				VSX VSXM
	Red: 24 VDC Black: COM	Blue	Red: 24 VDC Black: COM	Blue	

● Main valve

Descriptions	Vacuum generating valve	
Valve and operation	Pilot operated poppet valve	VSQ
Proof pressure MPa	1.05	
Valve	Normally closed	
Lubrication	Not required	
Effective cross-sectional area mm ²	Air supply port size ø4: 3.5	VSZM
	Air supply port size ø6: 4.5	

Vacuum pressure switch specifications

Item	With digital display		Without display
	With 2-point switch output (-DW)	With analog output (-DA)	Analog output only (-A0)
Factory default pressure kPa	-50 (SW1), -10(SW2)	-50	-
Current consumption mA	40 or less		15 or less
Pressure sensitive element	Diffused semiconductor pressure switch		
Working pressure kPa	-100 to 0		
Set pressure kPa	-99 to 0		-
Proof pressure Force MPa	0.2		
Storage temperature °C	-20 to 80 (atmospheric pressure, humidity 60% RH or less)		
Operating temperature °C	0 to 50 (no freezing)		
Operating humidity	35 to 85% RH (No condensation)		
Power supply voltage V	12 to 24 DC ±10% ripple (P-P) 10% or less		
Degree of protection	IEC standards IP40 or equivalent		
Output Number of points	2	1	-
Repeat Accuracy	±3% F.S. max.(at Ta=25°C)		-
Hysteresis	Fixed (2% F.S. or less)	Variable (Approx. 0 to 15% F.S.)	-
Switch output	NPN transistor open collector output 30V 80mA or less Residual voltage 0.8V or less		-
Analog output	Output voltage V	-	1 to 5
	Zero point voltage V	-	1±0.1
	Span voltage V	-	4±0.1
	Output current mA	-	1 or less (load resistance 5 kΩ or more)
	Linearity/hysteresis	-	±0.5% F.S.max.
Display kPa	-99 to 0 (2-digit red LED display)		-
Display frequency	Approx. 4 cycles/second		-
Display accuracy	±3% F.S. ±2digit		-
Resolution	1digit		-
Operation display	SW1: Red LED lights at set pressure and over	Red LED lights at set pressure and over	
	SW2: Green LED lights at set pressure and over		
Function	1. MODE change-over switch (ME or S1 or S2)	1. MODE change-over switch (ME or SW)	
	2. S1 set trimmer (2/3 rotation trimmer)	2. SW set trimmer (2/3 rotation trimmer)	
	3. S2 set trimmer (2/3 rotation trimmer)	3. HYS set trimmer (Approx. 0 to 15% F.S.)	

Vacuum break function specifications

Valve	Burst air flow rate ℓ/min (ANR)
Normally closed	0 to 7.5
Self-hold	0.2 to 2

*1: Value at supply pressure of 0.5 MPa.

*2: Note that for self-hold, the valve response specifications cannot be met outside the above flow rate setting range.

*3: The vacuum break air flow rate will vary with the diameter and length (piping resistance, etc.) of the vacuum side piping.

Vacuum filter specifications

Item	Vacuum filter
Element material	PVF (Polyvinyl formal)
Filtration rating μm	10
Filtration area mm ²	502
Replacement filter element model No.	VSX-E

Weight table

● Single unit

Model No.	Unit contents	Weight (g)
VSX-□□-□□S-□-D□	Vacuum ejector unit (atmospheric release, with vacuum pressure switch with LED display)	81
VSX-□□-□□J-□-D□	Vacuum ejector unit (common exhaust, with vacuum pressure switch with LED display)	84
VSX-□□-□□S-□-A0	Vacuum ejector unit (atmospheric release, with vacuum pressure switch with analog output)	78
VSX-□□-□□J-□-A0	Vacuum ejector unit (common exhaust, with vacuum pressure switch with analog output)	81
VSX-□□-□□S-□	Vacuum ejector unit (atmospheric release, vacuum pressure switch)	71
VSX-□□-□□J-□	Vacuum ejector unit (common exhaust, vacuum pressure switch)	74

*1 : DIN rail mount is heavier than the above weight by approx. 5 g.

● Manifold

Model No.	Manifold mounting unit content	Weight (g)
VSXM-□□□-□□S-□□-D□-2	Vacuum ejector unit, atmospheric release, with vacuum pressure switch with LED display, 2-station manifold	310
VSXM-□□□-□□□-□□-D□-2	Vacuum ejector unit, common exhaust, with vacuum pressure switch with LED display, 2-station manifold	330

*1 : 90 g heavier with each station increase.

*2 : The above weight is for the type equipped with vacuum pressure switch with LED display. Vacuum pressure switch with analog output built in is lighter than the above weight by 3 g/station, while the type without vacuum pressure switch is lighter than the above weight by 10 g/station.

Circuit diagram

● Normally closed

● Self hold type

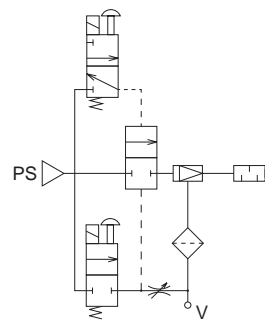
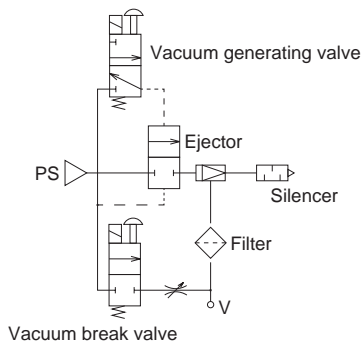

Ejector system

VSX

VSH/VSU
VSB/VSC

VSG

VSK
VSKM

VSJ
VSJM

VSN
VSNM

VSX
VSXM

VSQ

VSZM

How to order (single unit)

● 10.5 mm width integrated vacuum ejector unit, single unit

VSX - H 07 D - 6 6 J - 3 - DW - D

A Vacuum characteristics

B Nozzle diameter

C Valve

D Vacuum port (V)

E Air supply port (PS)

F Exhaust port (EX)

G Solenoid valve voltage

H Vacuum pressure switch specifications

I Mounting method

Code	Content
A Vacuum characteristics *1	
H	High vacuum/medium flow rate
L	Medium vacuum/large flow rate
E	High vacuum/low flow rate
B Nozzle diameter *1	
05	ø0.5
07	ø0.7
10	ø1.0
C Valve	
B	Normally closed
D	Self hold type
D Vacuum port (V)	
4	ø4 push-in fitting
6	ø6 push-in fitting
E Air supply port (PS)	
4	ø4 push-in fitting
6	ø6 push-in fitting
F Exhaust port (EX) *1	
S	Atmospheric release with silencer
J	ø6 push-in fitting common exhaust
G Solenoid valve voltage	
1	100 VAC
3	24 VDC
H Vacuum pressure switch specifications	
Blank	Without vacuum pressure switch
DW	With digital display, NPN output 2 points
DA	With digital display, NPN output 1 point + analog output
AO	Analog output
I Mounting method	
D	DIN rail mount
Blank	Direct mount

⚠ Precautions for model No. selection

*1 : With the combination of **A** and **B** for "L10", **F** "J" cannot be selected.

How to order (manifold)

- 10.5 mm width integrated vacuum ejector unit manifold

VSXM - H 07 D - 6 10 10 - 3 - 10 - DW

- 10.5 mm width integrated vacuum ejector unit manifold single unit

VSXM - H 07 D - 6 ————— 3 ————— DW

- 10.5 mm width integrated vacuum ejector unit manifold only

VSXM ————— 10 10 ————— 10

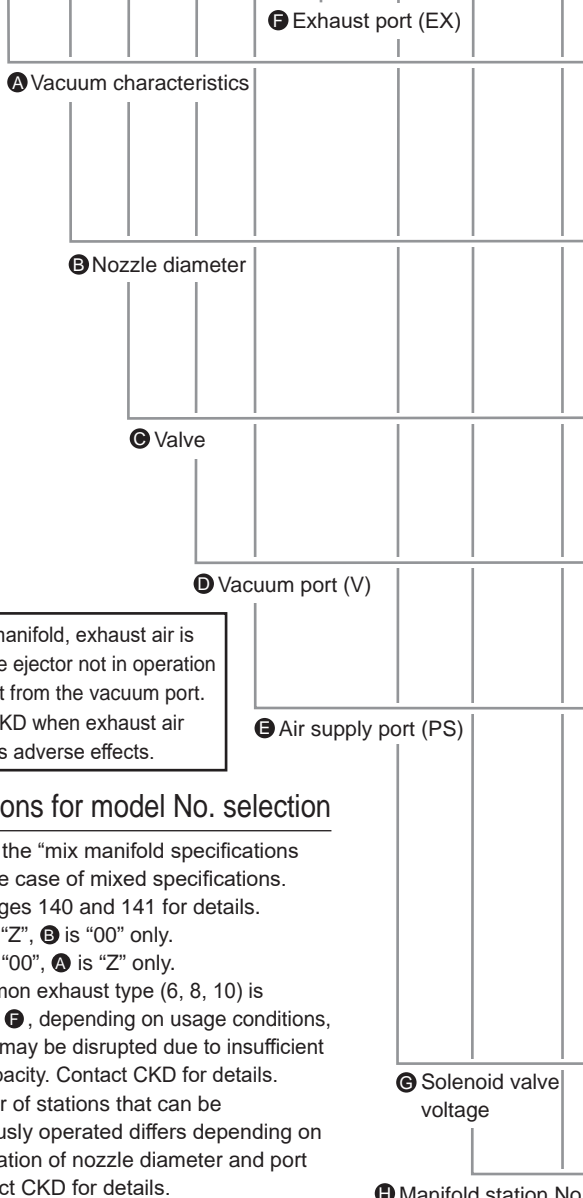

With the manifold, exhaust air is led into the ejector not in operation and output from the vacuum port. Contact CKD when exhaust air lead-in has adverse effects.

⚠ Precautions for model No. selection

- *1 : Indicate on the "mix manifold specifications sheet" in the case of mixed specifications. Refer to pages 140 and 141 for details.
- *2 : When **A** is "Z", **E** is "00" only. When **E** is "00", **A** is "Z" only.
- *3 : When common exhaust type (6, 8, 10) is selected for **F**, depending on usage conditions, exhaust air may be disrupted due to insufficient exhaust capacity. Contact CKD for details.
- *4 : The number of stations that can be simultaneously operated differs depending on the combination of nozzle diameter and port size. Contact CKD for details.

● Maintenance part model No.

- Filter element
VSX-E
- Silencer element
VSX-SE
- Silencer element F
VSX-EF
- Silencer element D
VSX-ED
- Silencer element for manifold
VSXPM-SE

Code	Content	Type			Ejector system
		Manifold	Single unit for manifold	Manifold only	
A Vacuum characteristics *1, *2					
H	High vacuum/medium flow rate	●	●		Ejector system
L	Medium vacuum/large flow rate	●	●		
E	High vacuum/low flow rate	●	●		
Z	For mixed specs (indicate breakdown on specs sheet.)	●			
B Nozzle diameter *1, *2					
05	ø0.5	●	●		VSY
07	ø0.7	●	●		
10	ø1.0	●	●		
00	For mixed specs (indicate breakdown on specs sheet.)	●			
C Valve *1					
B	Normally closed	●	●		VSHVSV VSBVSC
D	Self hold type	●	●		
Z	For mixed specs (indicate breakdown on specs sheet.)	●			
D Vacuum port (V) *1					
4	ø4 push-in fitting	●	●		VSG
6	ø6 push-in fitting	●	●		
CX	For mixed fittings (indicate breakdown on specs sheet.)	●			
E Air supply port (PS)					
4	ø4 push-in fitting	●		●	VSK VSKM
6	ø6 push-in fitting	●		●	
8	ø8 push-in fitting	●		●	VSJ VSJM
10	ø10 push-in fitting	●		●	
F Exhaust port (EX) *3					
S	Atmospheric release with silencer	●		●	VSN VSNM
6	ø6 push-in fitting common exhaust	●		●	
8	ø8 push-in fitting common exhaust	●		●	VSX VSXM
10	ø10 push-in fitting common exhaust	●		●	
G Solenoid valve voltage					
1	100 VAC	●	●		VSQ
3	24 VDC	●	●		
H Manifold station No. *4					
2	2 stations	●		●	VSZM
to	to				
10	10 stations				
I Vacuum pressure switch specifications *1					
Blank	Without vacuum pressure switch	●	●		VSQ
DW	With digital display, NPN output 2 points	●	●		
DA	With digital display, NPN output 1 point + analog output	●	●		
AO	Analog output	●	●		
Z	For mixed specs (indicate breakdown on specs sheet.)	●			

Vacuum characteristics, flow characteristics

●VSX-H05, VSX-L05, VSX-E05

●VSX-H07, VSX-L07, VSX-E07

Vacuum characteristics

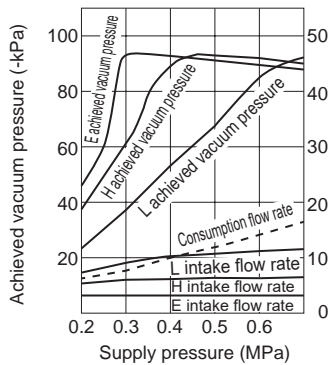

Flow characteristics

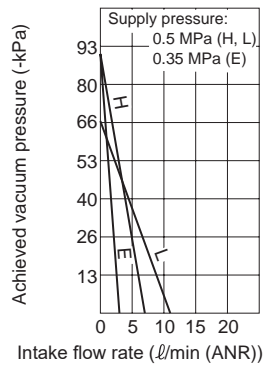

Vacuum characteristics

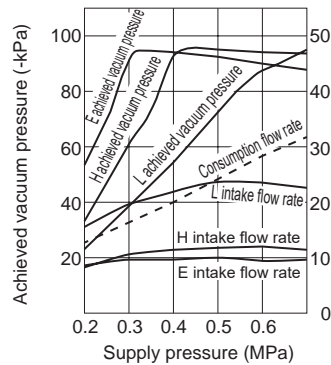

Flow characteristics

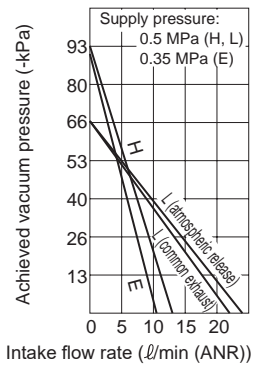

Ejector system

VSX

●VSX-H10□□□□J, VSX-L10□□□□J, VSX-E10□□□□J

●VSX-H10□□□□S, VSX-L10□□□□S, VSX-E10□□□□S

Vacuum characteristics

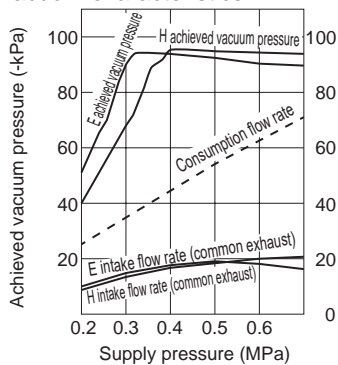

Flow characteristics

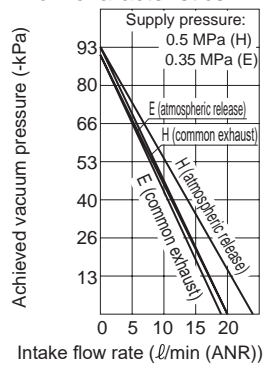

Vacuum characteristics

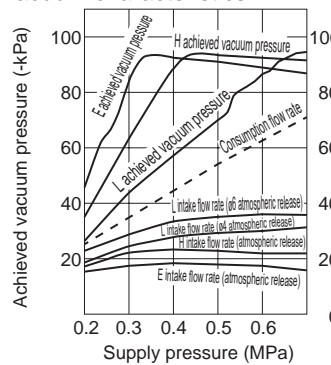

Flow characteristics

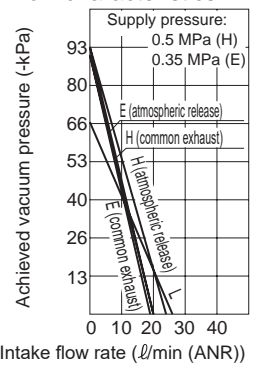

VSH/VSU
VSB/VSC

VSG

VSK
VSKM

VSJ
VSJM

VSN
VSNM

VSX
VSXM

VSQ

VSZM

- Supply pressure with the characteristics described above occurs at vacuum generation.
- Achieved vacuum pressure with the characteristics described above produces abnormal noise (soft clicking sound) at supply pressure just before reaching the peak value. When this abnormal noise occurs, the characteristics become unstable and operation becomes louder. Reset the supply pressure, as it may affect the sensor, etc., and cause trouble.
 - Ex. 1 : Source pressure is 0.5 MPa with the H vacuum ejector. During vacuum ejector operation, supply pressure drops to 0.43 MPa due to pressure drop, and abnormal noise is generated. → Reset supply pressure to 0.5 MPa during vacuum ejector operation.
- Carry out piping or equipment selection with 3 times the effective cross-sectional area of the nozzle diameter cross-sectional area as a guideline. Satisfactory vacuum characteristics cannot be obtained if adequate supply air flow rate is not maintained. (A soft clicking sound occurs at set pressure. Insufficient intake flow rate, insufficient achievement of achieved vacuum pressure, etc.)
 - Ex. 2 : Abnormal noise occurs even when pressure is 0.5 MPa with H vacuum ejector during vacuum ejector operation. → Insufficient supply air flow rate. (Supply air flow rate is restricted in front of the vacuum ejector by piping resistance, etc., and supply air flow rate satisfying the properties is not obtained. → Select piping components that can secure the required effective cross-sectional area.)
 - Ex. 3 : For vacuum ejector with 1.0 mm nozzle diameter, cross-sectional area is $0.5^2 \times \pi = 0.785 \text{ mm}^2 \times 3 = 2.35 \text{ mm}^2$. Therefore, carry out piping and equipment selection that ensures an effective cross-sectional area of 2.3 mm² or greater.

Internal structure (single unit)

Example) VSX-□□□-□□S-□□
Type with vacuum pressure switch

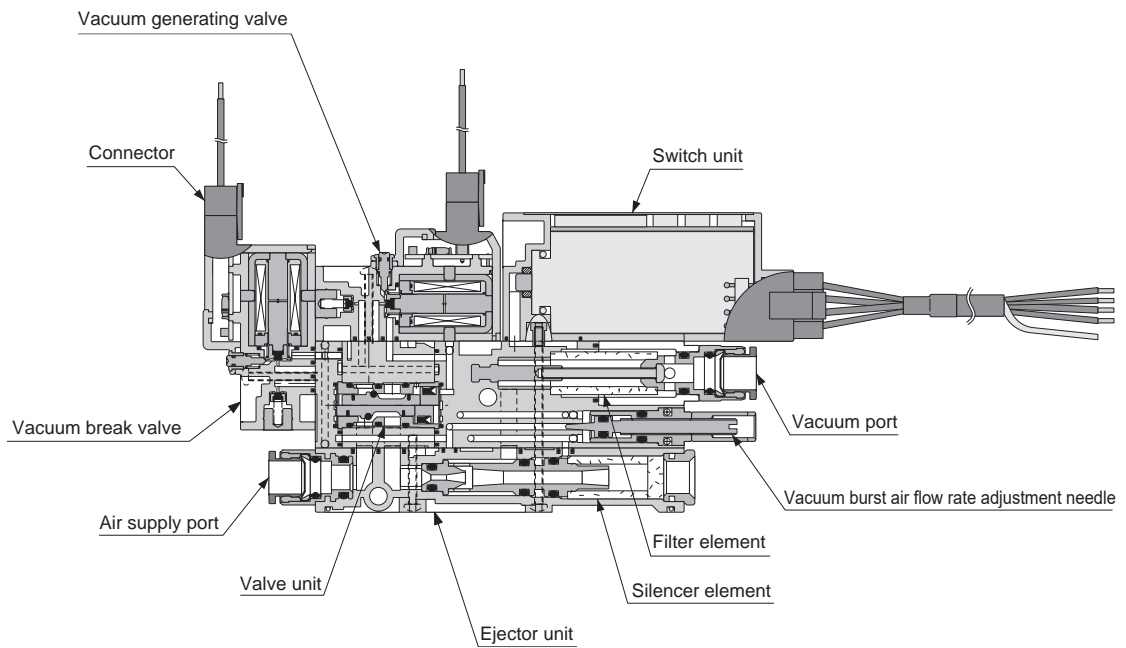

Example) VSX-□□□-□□S-□□
Type without vacuum pressure switch

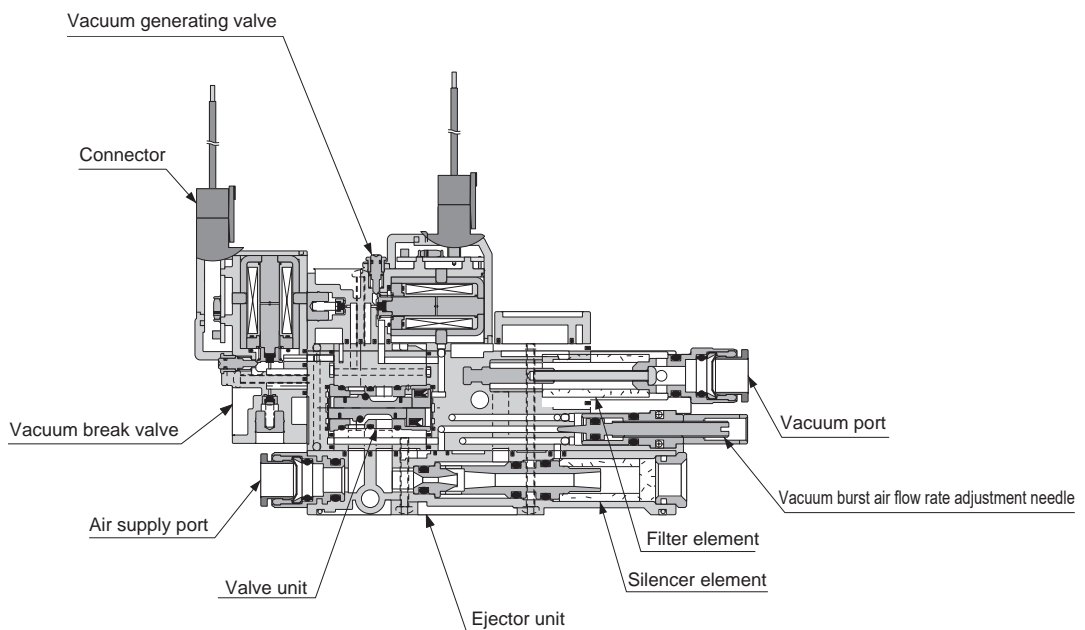

Ejector system

VSY

VSH/VSU
VSB/VSC

VSG

VSK
VSKM

VSJ
VSJM

VSN
VSNM

VSX
VSXM

VSQ

VSZM

Internal structure (manifold)

Example) VSXM-□□□□S-□□□

Type with vacuum pressure switch

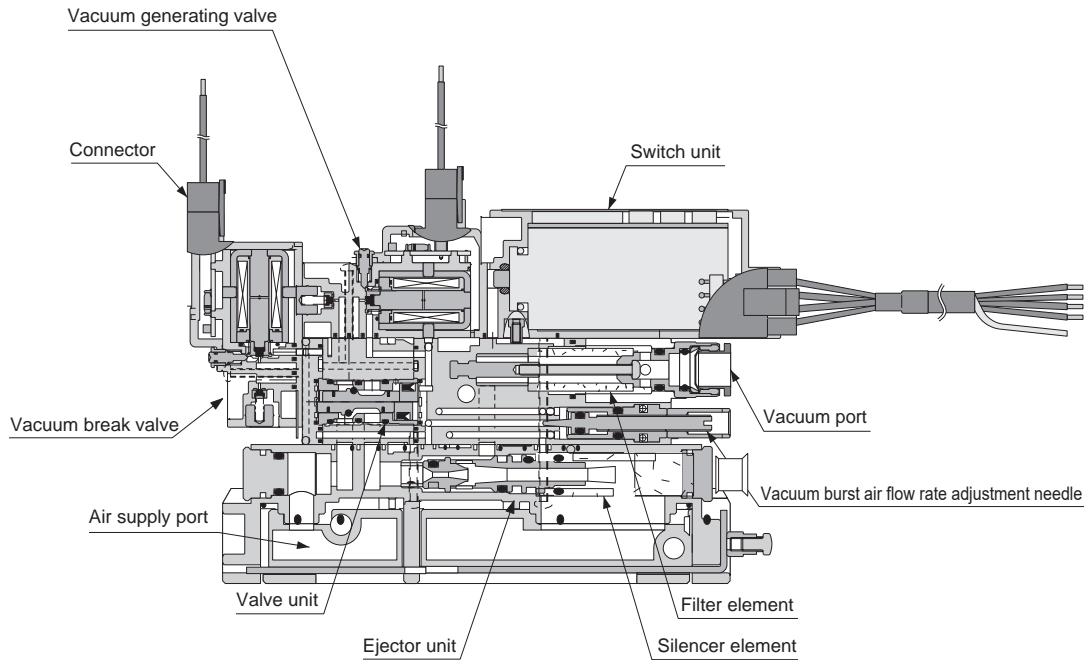

Ejector system

VSX

VSH/VSU
VSB/VSC

VSG

VSK
VSKM

Example) VSXM-□□□□S-□□□

Type without vacuum pressure switch

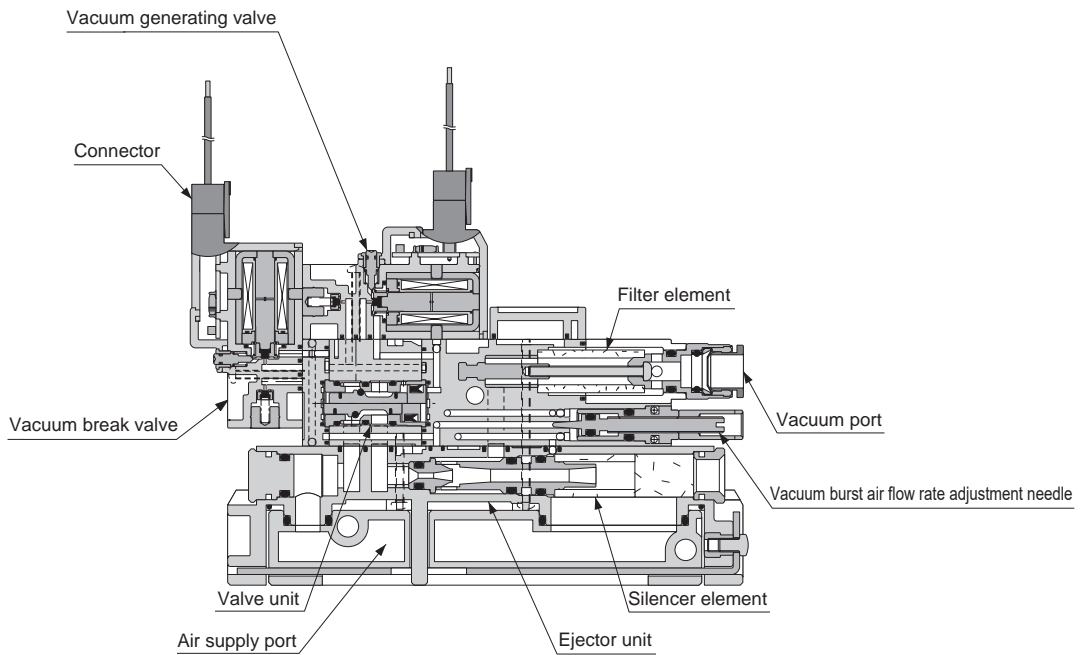

VSJ
VSJM

VSN
VSNM

VSX
VSXM

VSQ

VSZM

Dimensions (single unit, atmospheric release, without vacuum pressure switch)

● Direct mounting

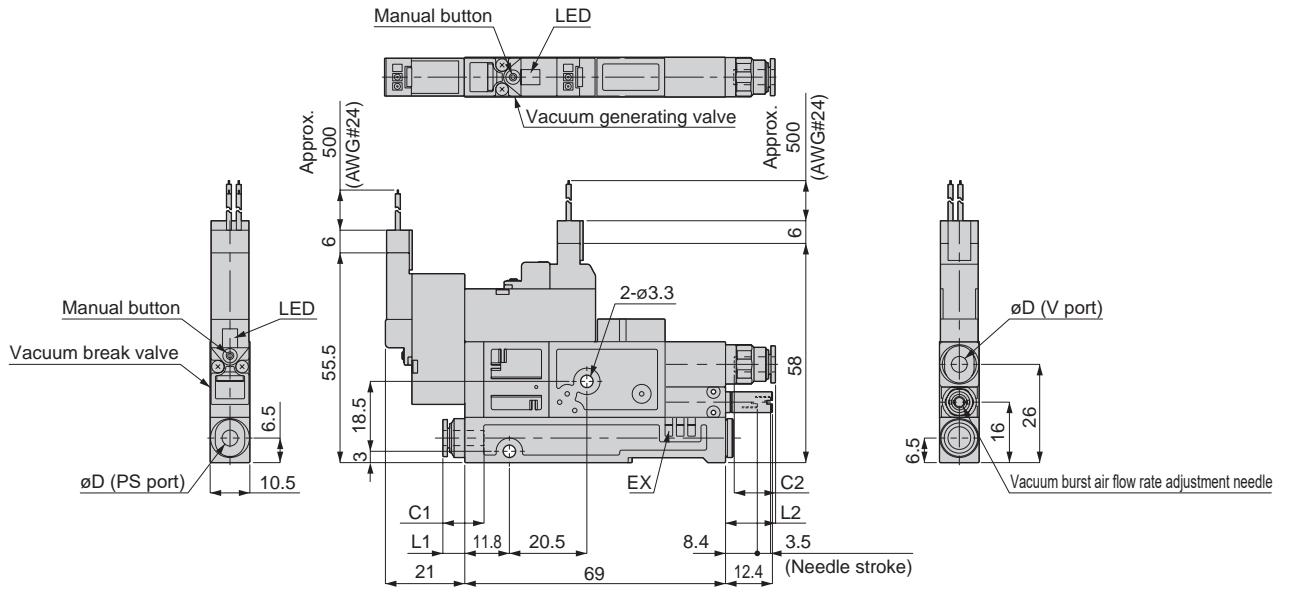

Unit: mm

Model No.	Tube O.D. (øD)	C1	C2	L1	L2
VSX-□□□-□□S-□	4	11.2	11.2	6.1	13.5
	6	11.9	11.9	8.9	13.7

● DIN rail mounting

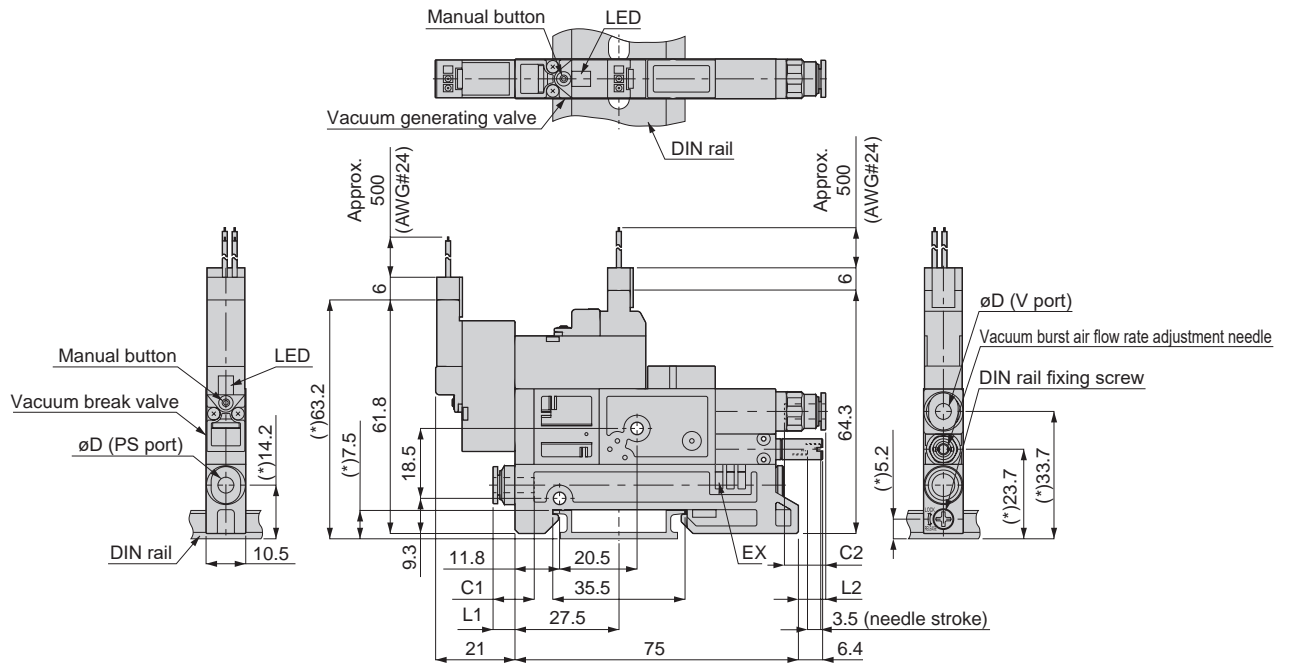

Note) Dimensions of the part with (*) mark are the values when DIN rail height is 7.5 mm.

Unit: mm

Model No.	Tube O.D. (øD)	C1	C2	L1	L2
VSX-□□□-□□S-□-D	4	11.2	11.2	6.1	7.5
	6	11.9	11.9	8.9	7.7

Ejector system

VSY

VSH/VSU
VSB/VSC

VSG

VSK
VSKM

VSJ
VSJM

VSN
VSNM

VSX
VSXM

VSQ

VSZM

Dimensions (single unit, atmospheric release, with vacuum pressure switch with 2-point switch output with digital display)

● Direct mounting

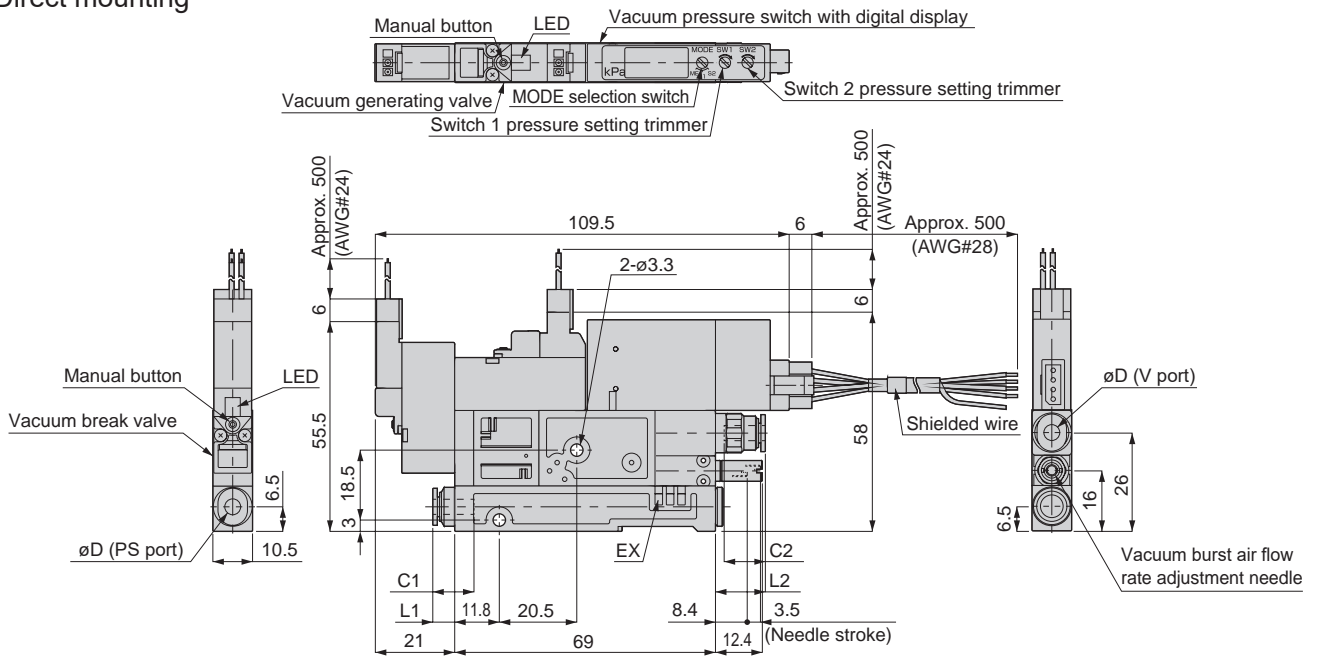

Unit: mm

Model No.	Tube O.D. (øD)	C1	C2	L1	L2
VSX-□□□-□□S-□-DW	4	11.2	11.2	6.1	13.5
	6	11.9	11.9	8.9	13.7

● DIN rail mounting

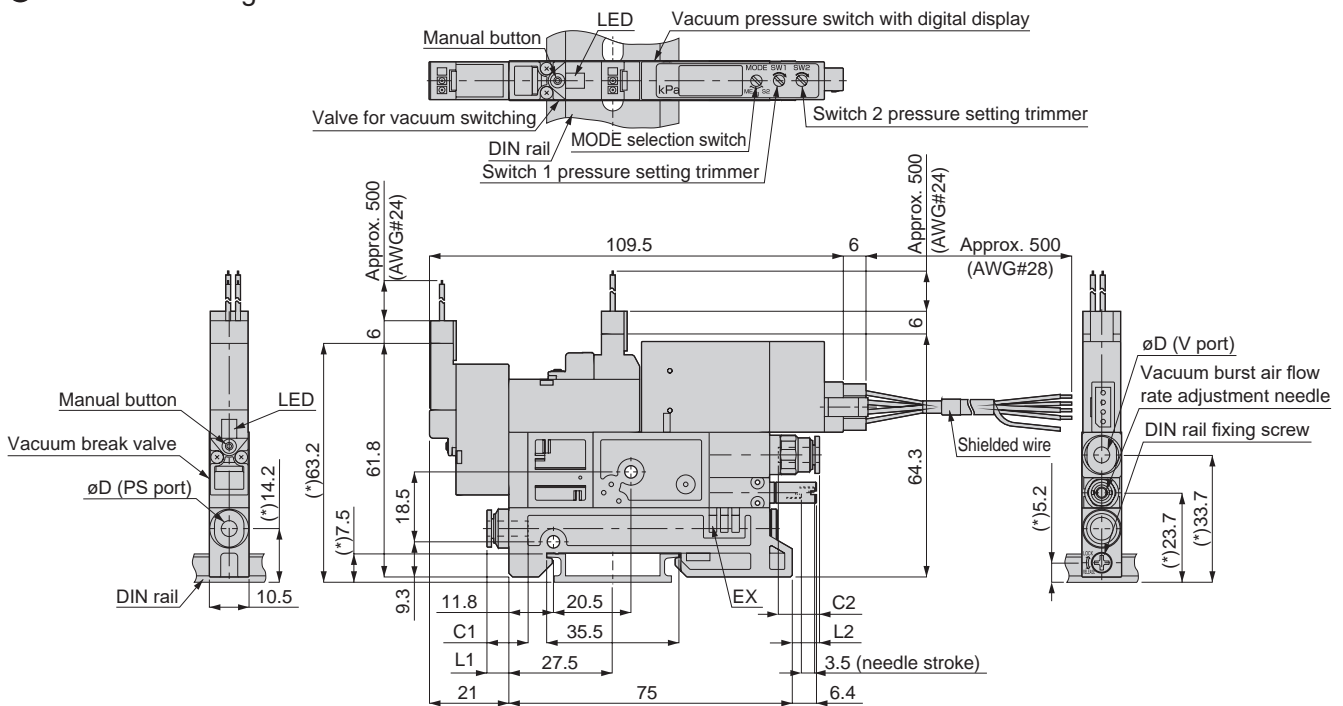

Note) Dimensions of the part with (*) mark are the values when DIN rail height is 7.5 mm.

Unit: mm

Model No.	Tube O.D. (øD)	C1	C2	L1	L2
VSX-□□□-□□S-□-DW-D	4	11.2	11.2	6.1	7.5
	6	11.9	11.9	8.9	7.7

Dimensions (single unit, atmospheric release, analog output with digital display, with vacuum pressure switch with switch output)

● Direct mounting

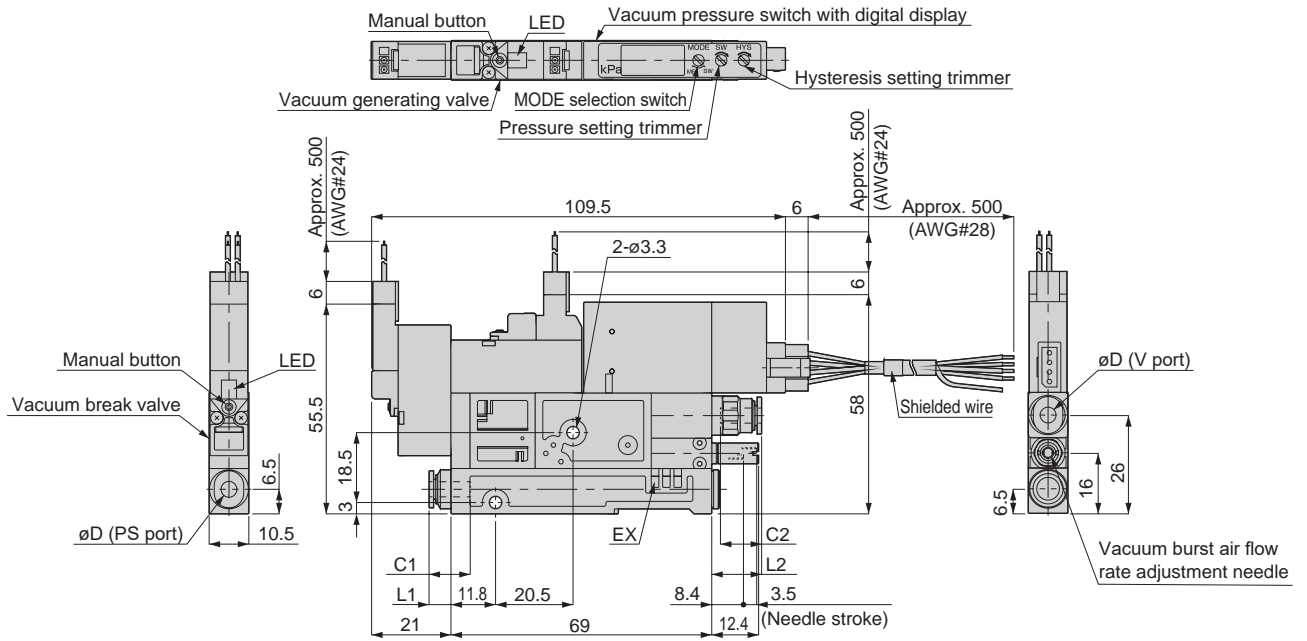

Unit: mm

Model No.	Tube O.D. (øD)	C1	C2	L1	L2
VSX-□□□-□□S-□-DA	4	11.2	11.2	6.1	13.5
	6	11.9	11.9	8.9	13.7

● DIN rail mounting

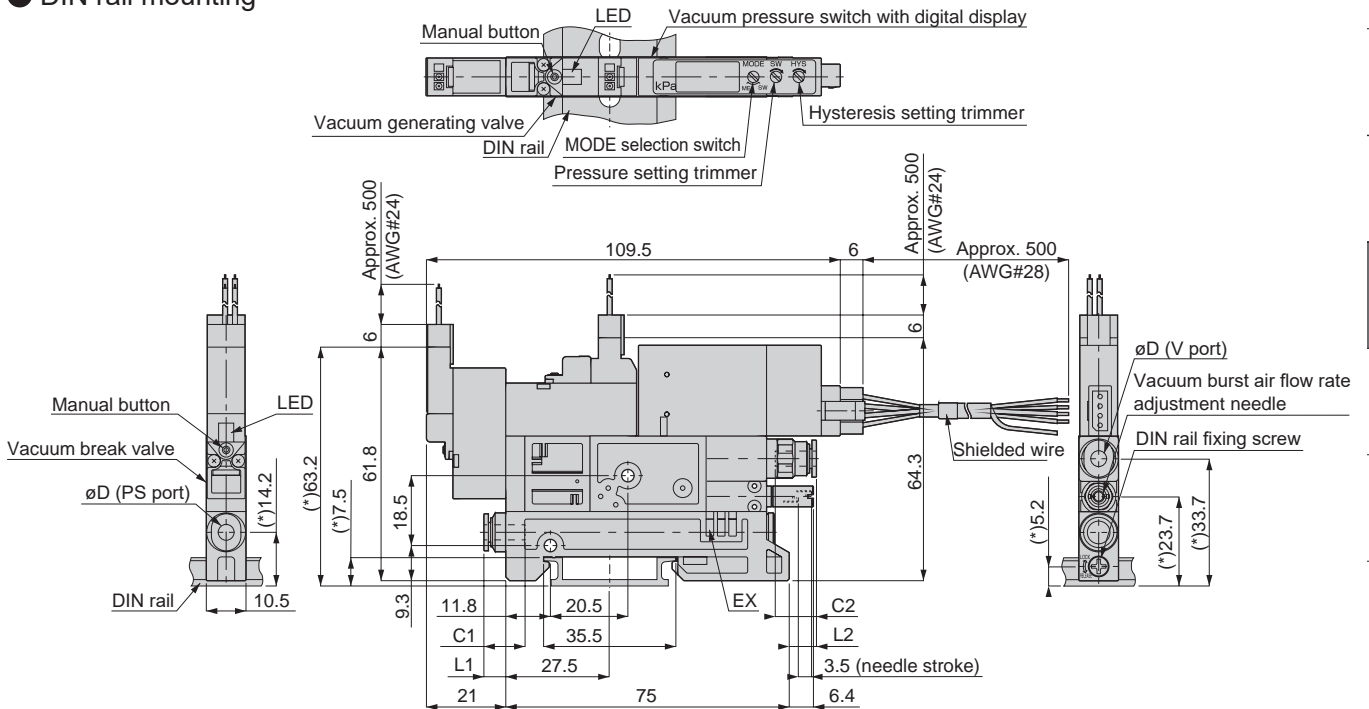

Note) Dimensions of the part with (*) mark are the values when DIN rail height is 7.5 mm.

Unit: mm

Model No.	Tube O.D. (øD)	C1	C2	L1	L2
VSX-□□□-□□S-□-DA-D	4	11.2	11.2	6.1	7.5
	6	11.9	11.9	8.9	7.7

Ejector system

VSY

VSH/VSU
VSB/VSC

VSG

VSK
VSKM

VSJ
VSJM

VSN
VSNM

VSX
VSXM

VSQ

VSZM

Dimensions (single unit, atmospheric release, with vacuum pressure switch with analog output)

● Direct mounting

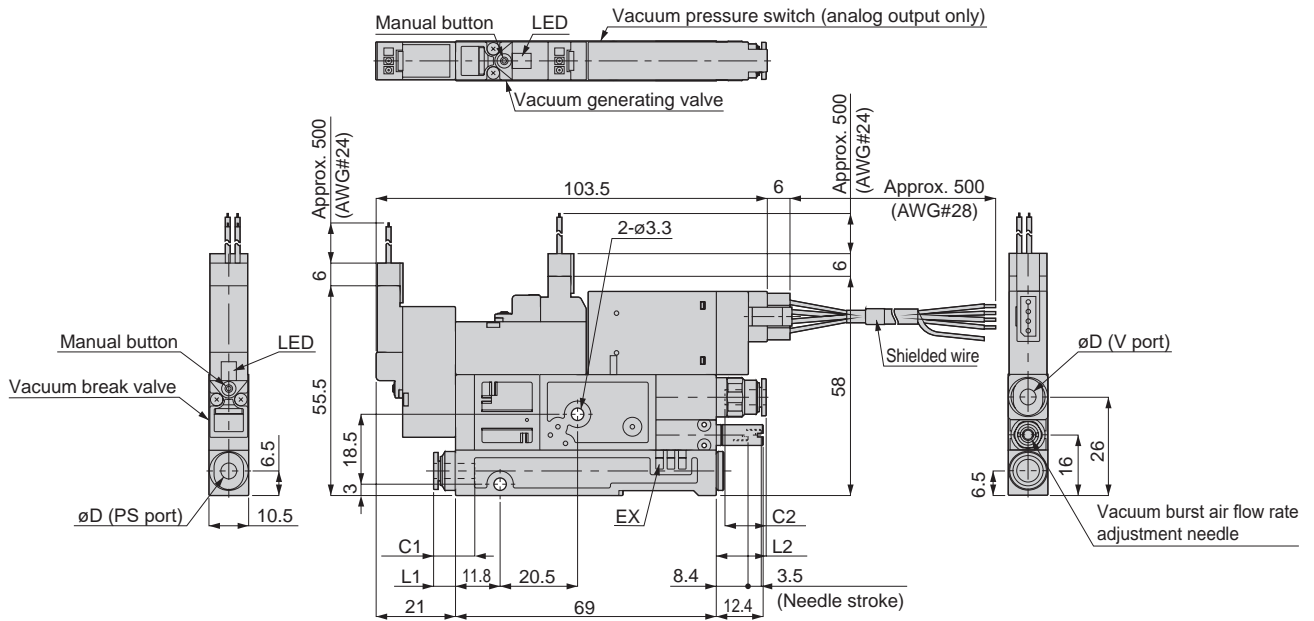

Unit: mm

Model No.	Tube O.D. (øD)	C1	C2	L1	L2
VSX-□□□-□□S-□-A0	4	11.2	11.2	6.1	13.5
	6	11.9	11.9	8.9	13.7

● DIN rail mounting

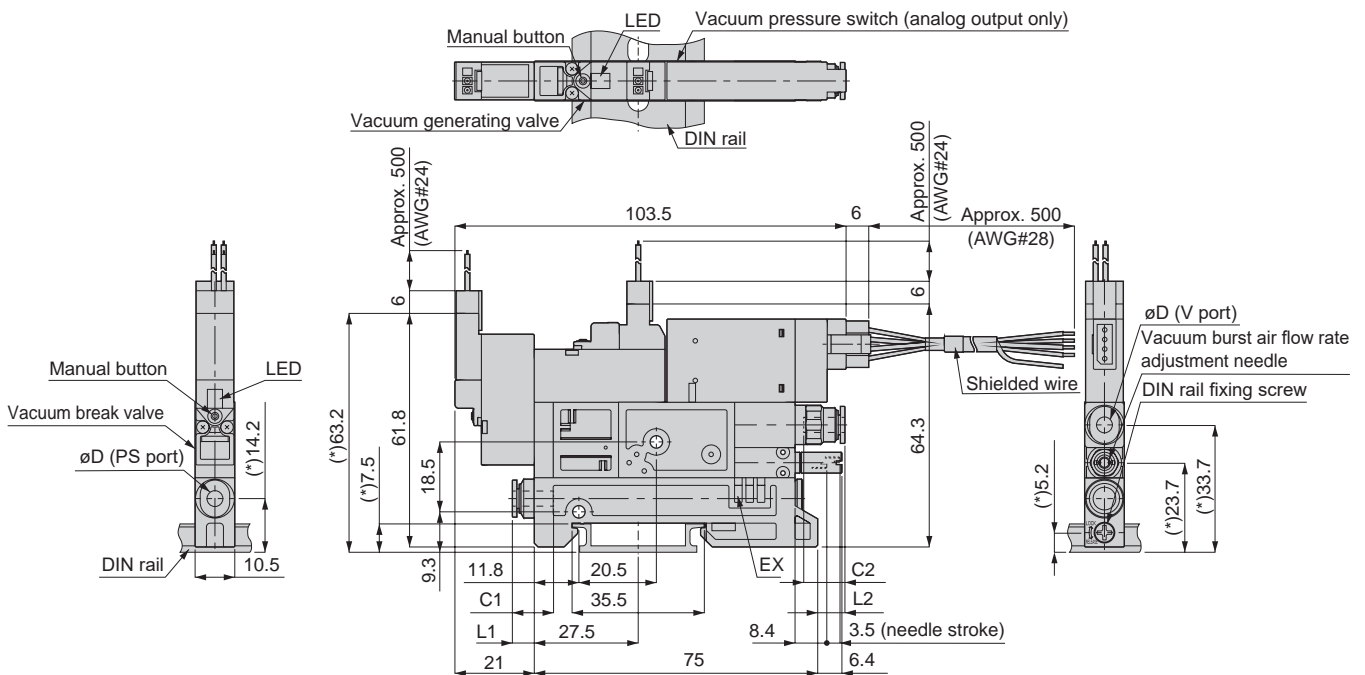

Note) Dimensions of the part with (*) mark are the values when DIN rail height is 7.5 mm.

Unit: mm

Model No.	Tube O.D. (øD)	C1	C2	L1	L2
VSX-□□□-□□S-□-A0-D	4	11.2	11.2	6.1	7.5
	6	11.9	11.9	8.9	7.7

Dimensions (single unit, common exhaust, without vacuum pressure switch)

● Direct mounting

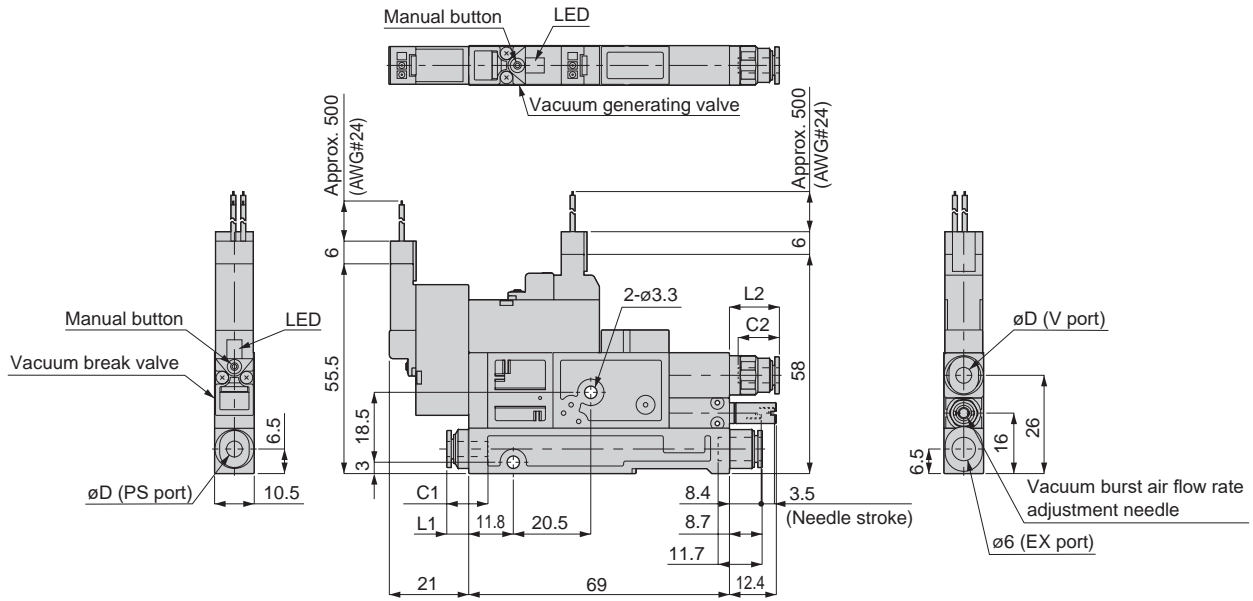

Unit: mm

Model No.	Tube O.D. (øD)	C1	C2	L1	L2
VSX-□□□-□□J-□	4	11.2	11.2	6.1	13.5
	6	11.9	11.9	8.9	13.7

● DIN rail mounting

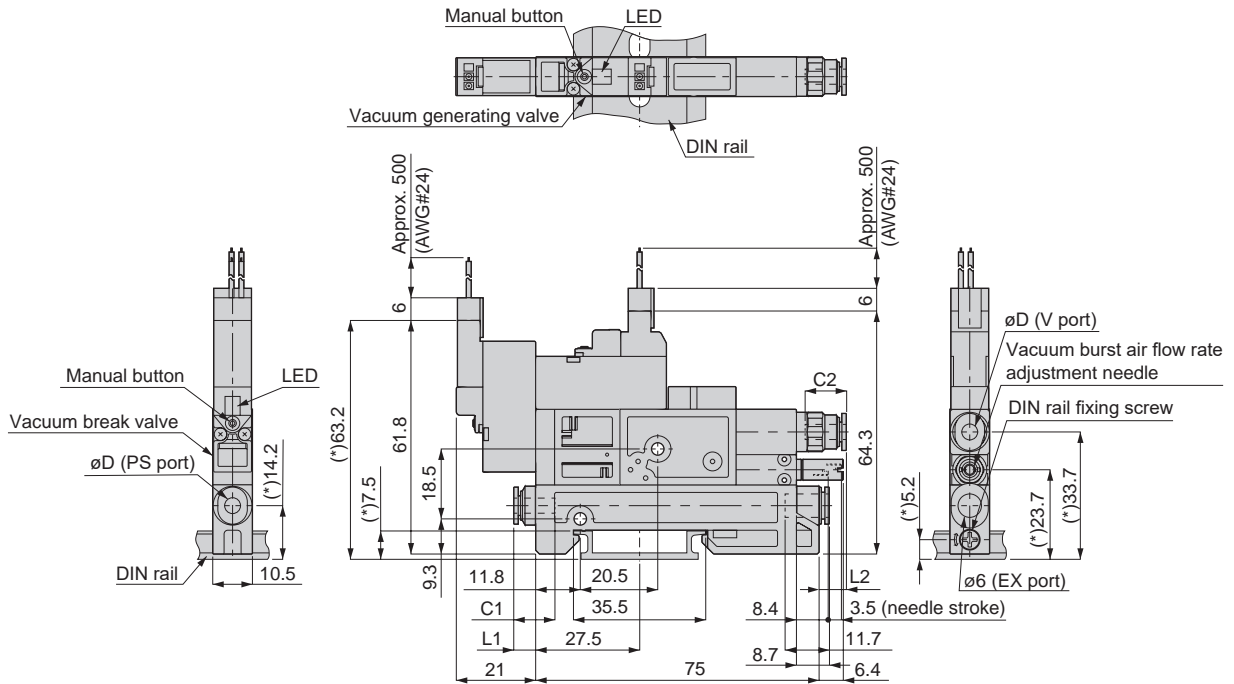

Note) Dimensions of the part with (*) mark are the values when DIN rail height is 7.5 mm.

Unit: mm

Model No.	Tube O.D. (øD)	C1	C2	L1	L2
VSX-□□□-□□J-□-D	4	11.2	11.2	6.1	7.5
	6	11.9	11.9	8.9	7.7

Ejector system

VSY

VSH/VSU
VSB/VSC

VSG

VSK
VSKM

VSJ
VSJM

VSN
VSNM

VSX
VSXM

VSQ

VSZM

Dimensions (single unit, common exhaust, with vacuum pressure switch with 2-point switch output with digital display)

● Direct mounting

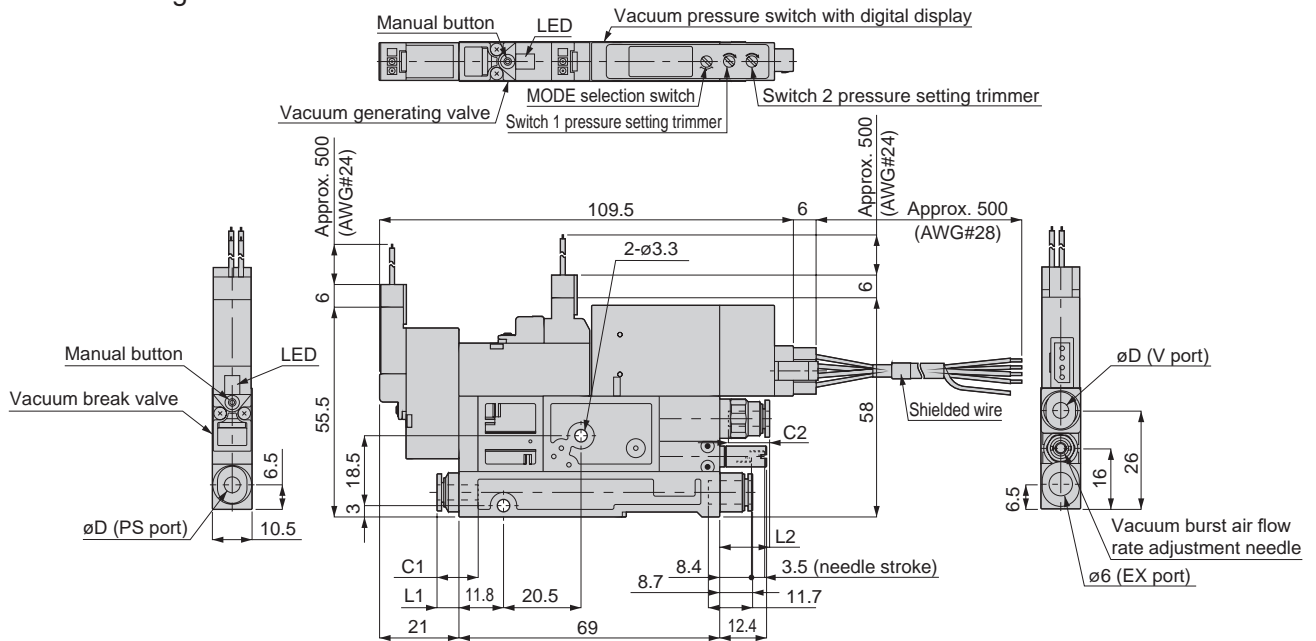

Unit: mm

Model No.	Tube O.D. (ϕ D)	C1	C2	L1	L2
VSX-□□□-□□J-□-DW	4	11.2	11.2	6.1	13.5
	6	11.9	11.9	8.9	13.7

● DIN rail mounting

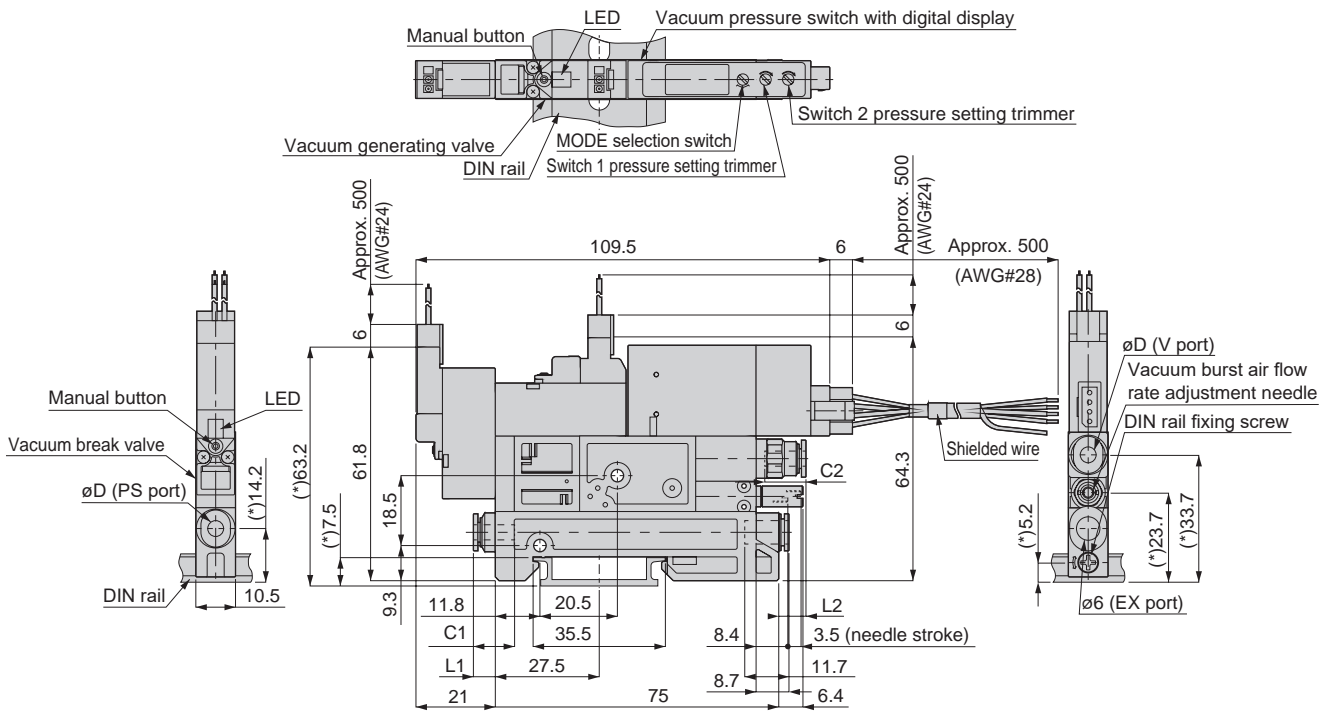

Note) Dimensions of the part with (*) mark are the values when DIN rail height is 7.5 mm.

Unit: mm

Model No.	Tube O.D. (ϕ D)	C1	C2	L1	L2
VSX-□□□-□□J-□-DW-D	4	11.2	11.2	6.1	7.5
	6	11.9	11.9	8.9	7.7

Dimensions (single unit, common exhaust, analog output with digital display, with vacuum pressure switch with switch output)

● Direct mounting

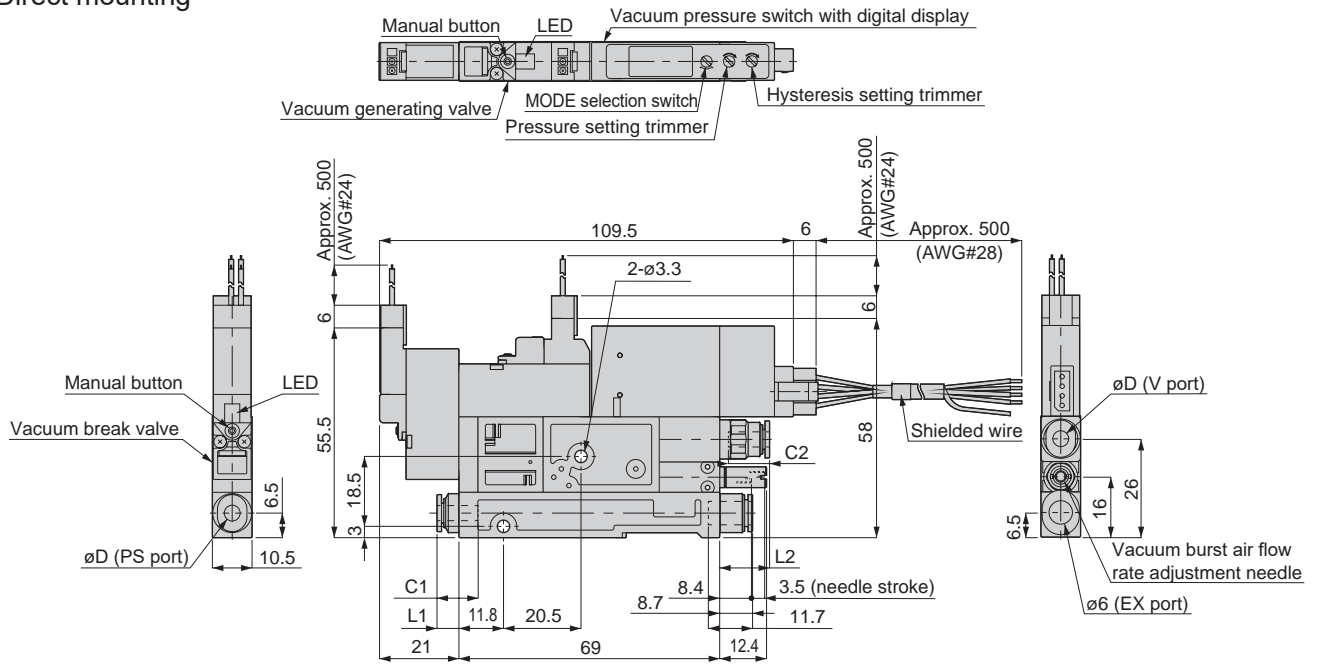

Unit: mm

Model No.	Tube O.D. (øD)	C1	C2	L1	L2
VSX-□□□-□□J-□-□-DA	4	11.2	11.2	6.1	13.5
	6	11.9	11.9	8.9	13.7

● DIN rail mounting

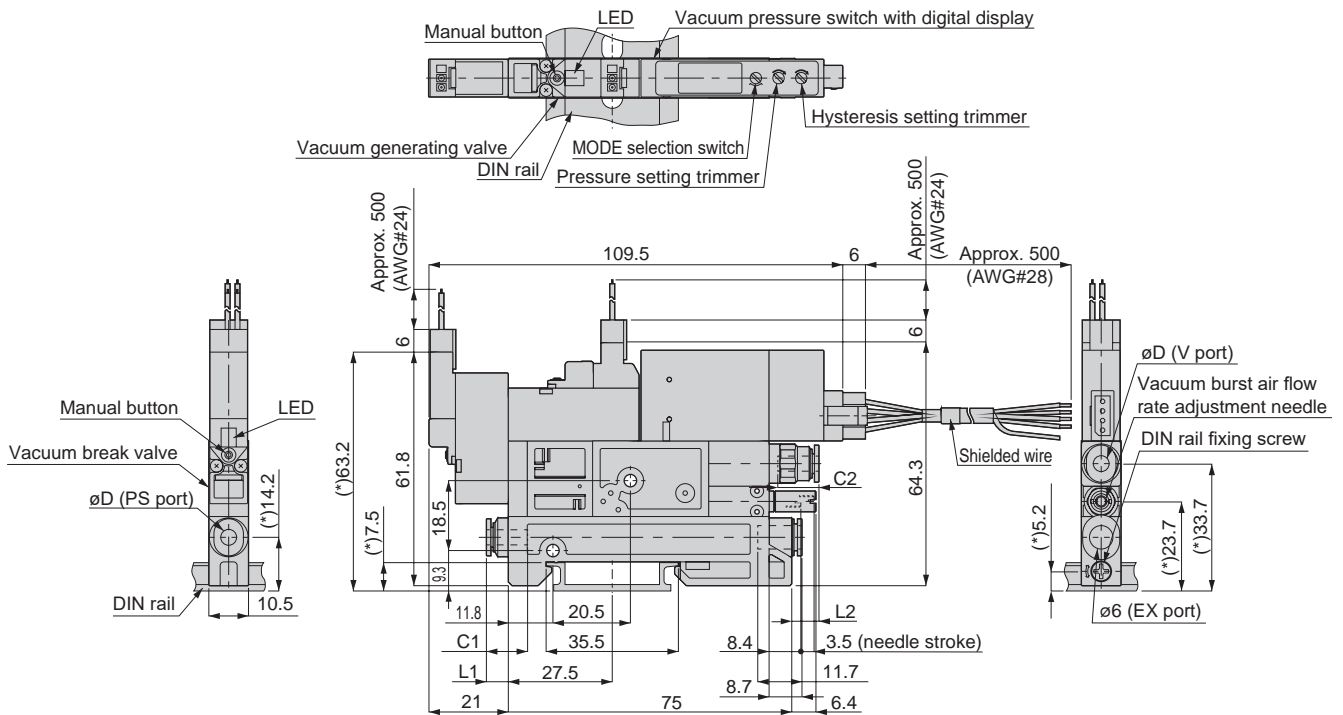

Note) Dimensions of the part with (*) mark are the values when DIN rail height is 7.5 mm.

Unit: mm

Model No.	Tube O.D. (øD)	C1	C2	L1	L2
VSX-□□□-□□J-□-□-DA-D	4	11.2	11.2	6.1	7.5
	6	11.9	11.9	8.9	7.7

Ejector system

VSY

VSH/VSU
VSB/VSC

VSG

VSK
VSKM

VSJ
VSJM

VSN
VSNM

VSX
VSXM

VSQ

VSZM

Dimensions (manifold, VSXM, without vacuum pressure switch)

● Common exhaust

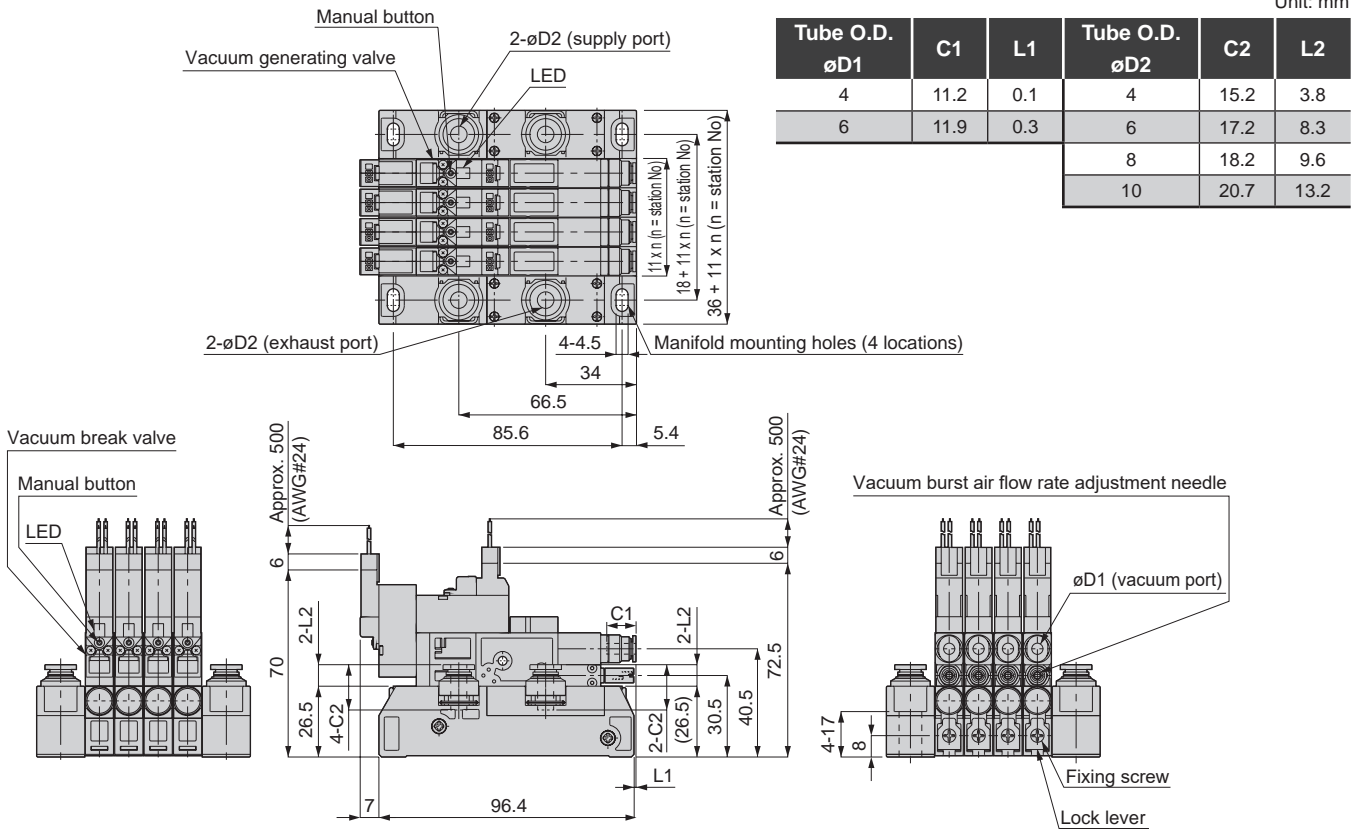

Ejector system

VSY

VSH/VSU
VSB/VSC

VSG

● Atmosphere release

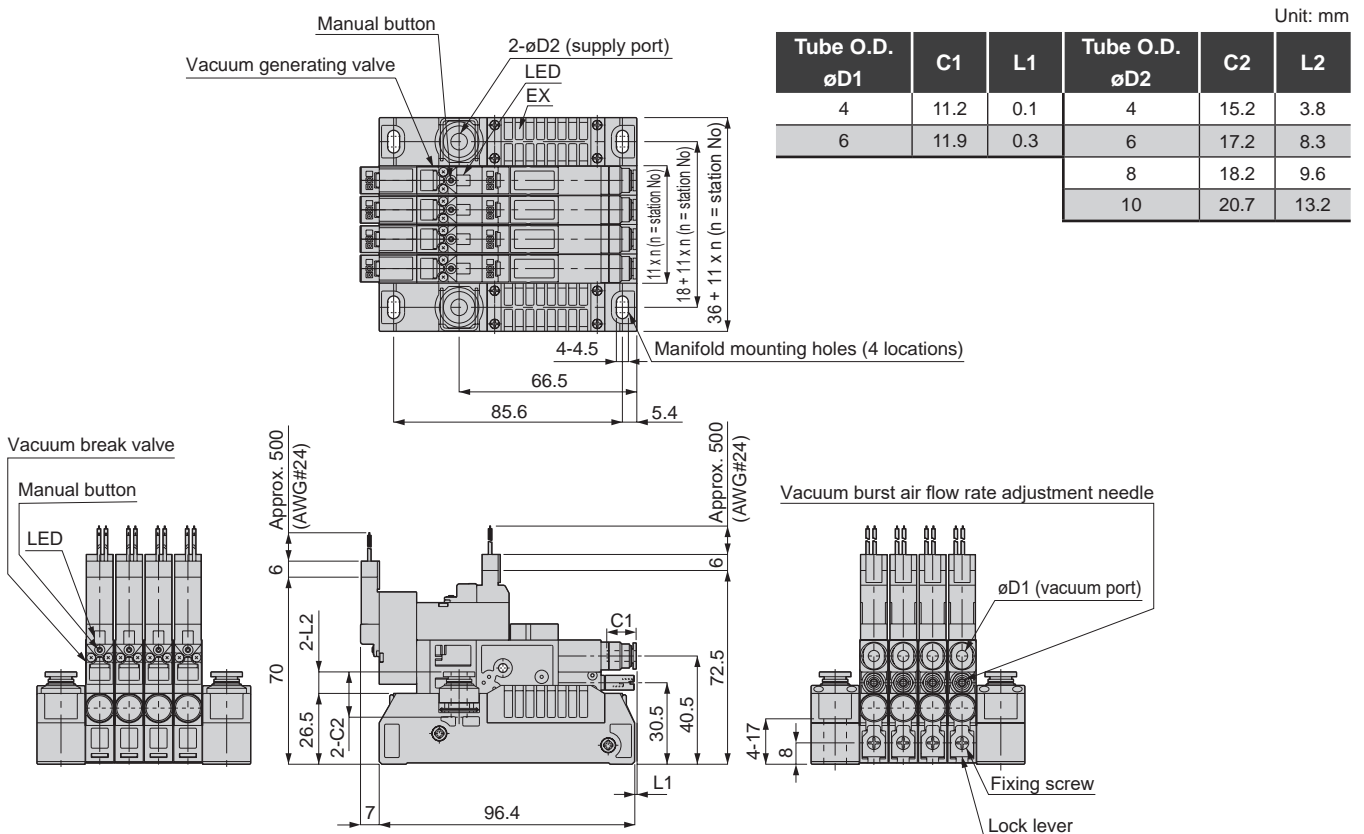

VSK
VSKM

VSJ
VSJM

VSN
VSNM

VSX
VSXM

VSQ

VSZM

Dimensions (manifold VSXM, with 2-point switch output with digital display, with vacuum pressure switch)

Common exhaust

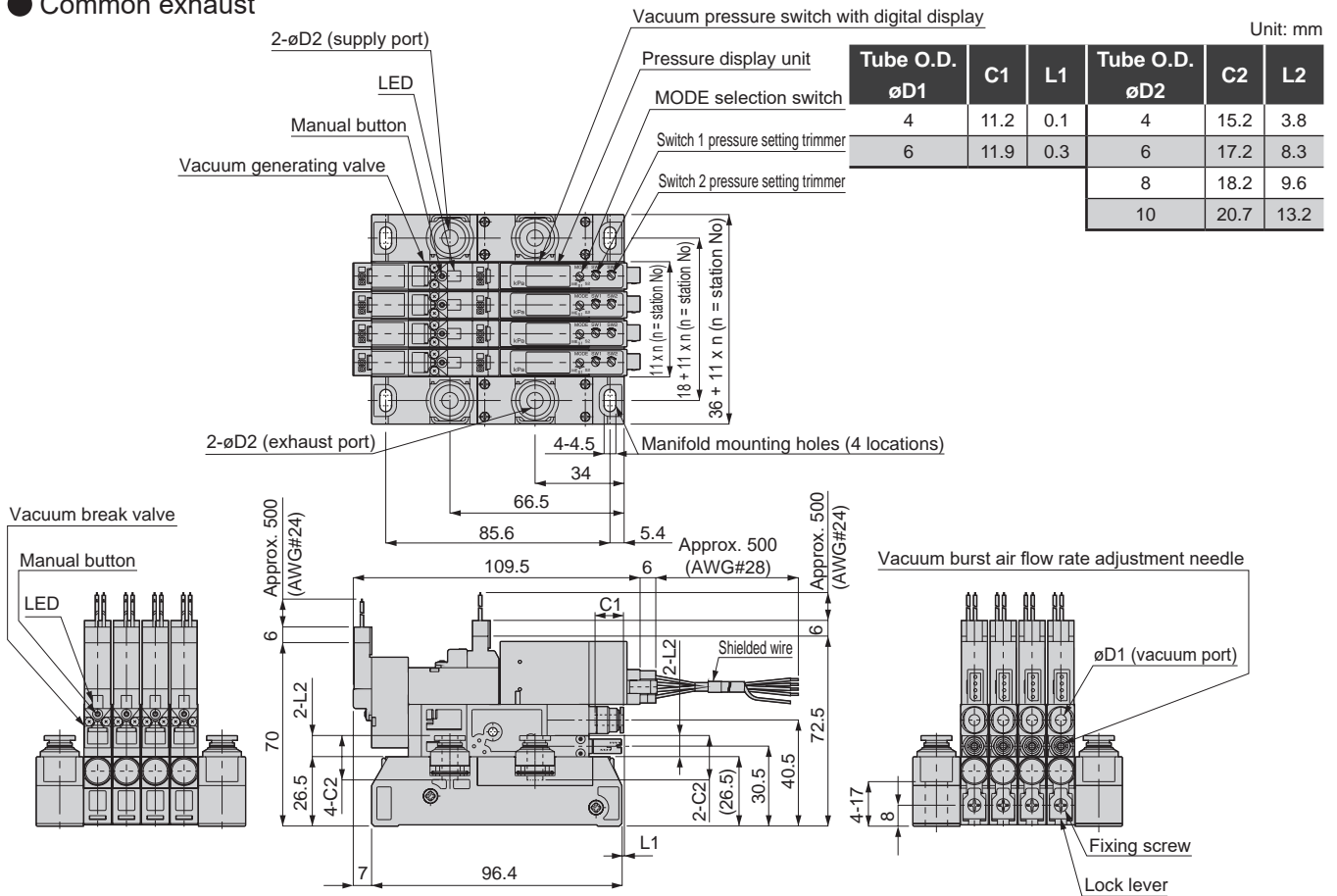

Atmosphere release

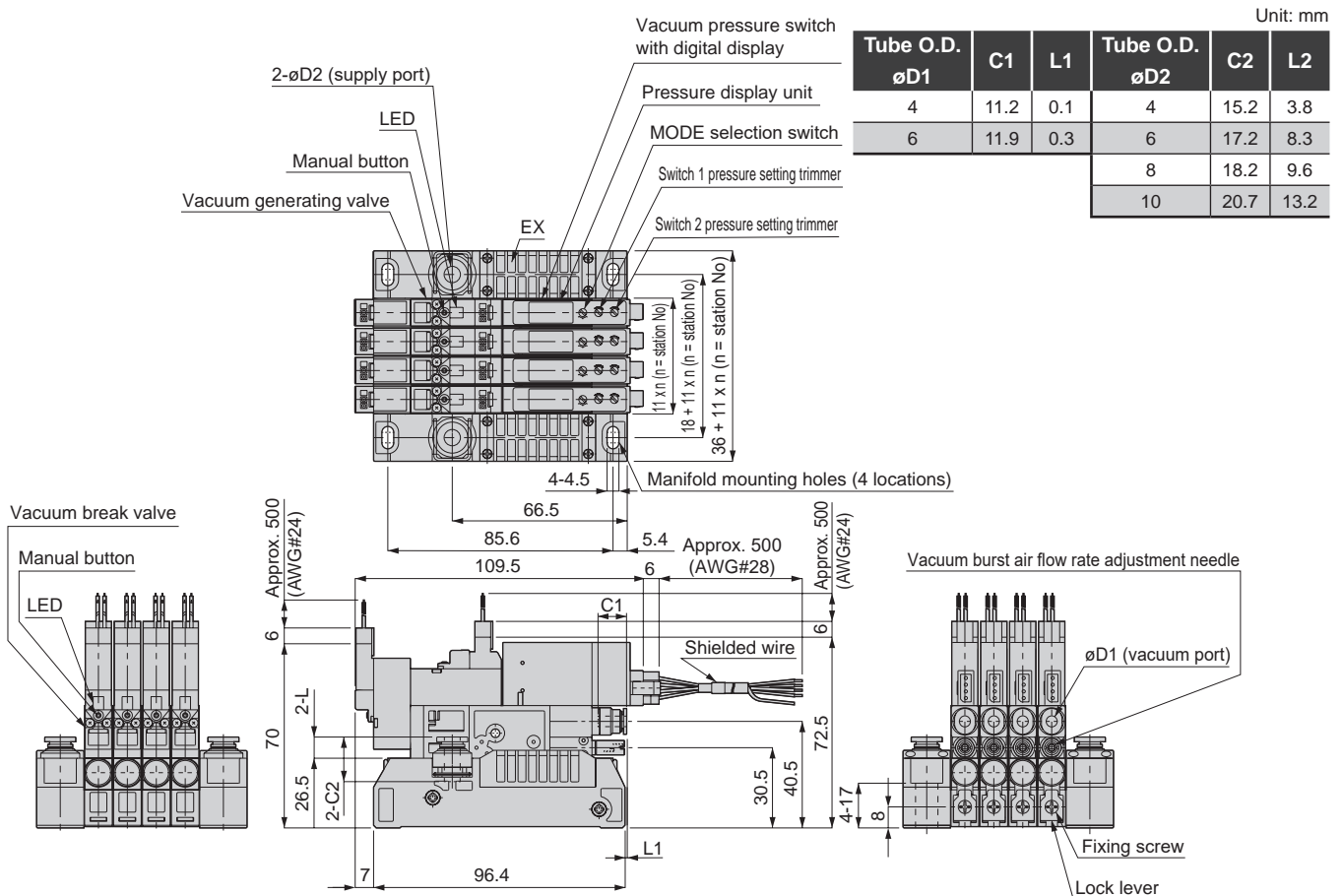

Dimensions (manifold VSXM, analog output with digital display, with vacuum pressure switch with switch output)

Common exhaust

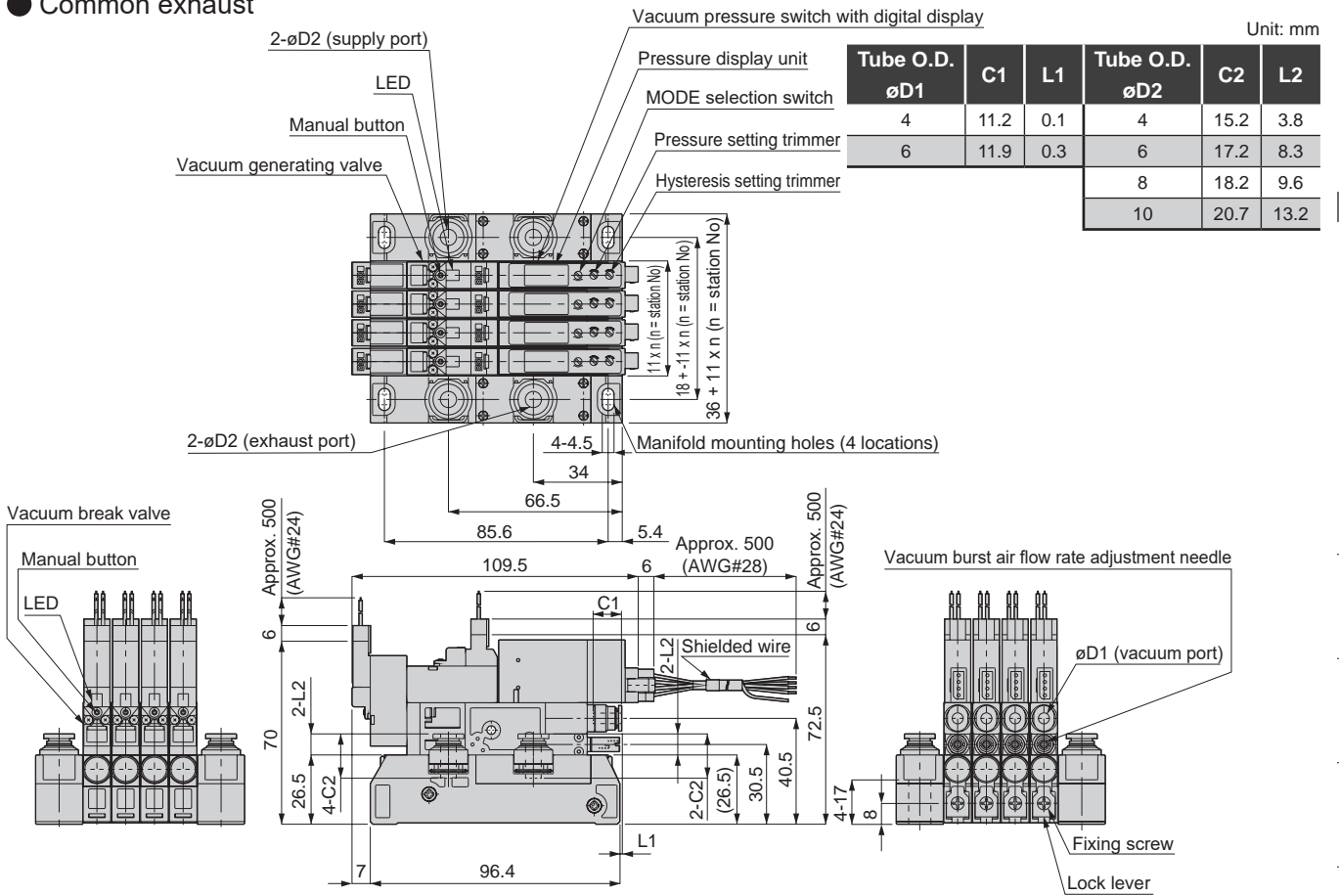

Atmosphere release

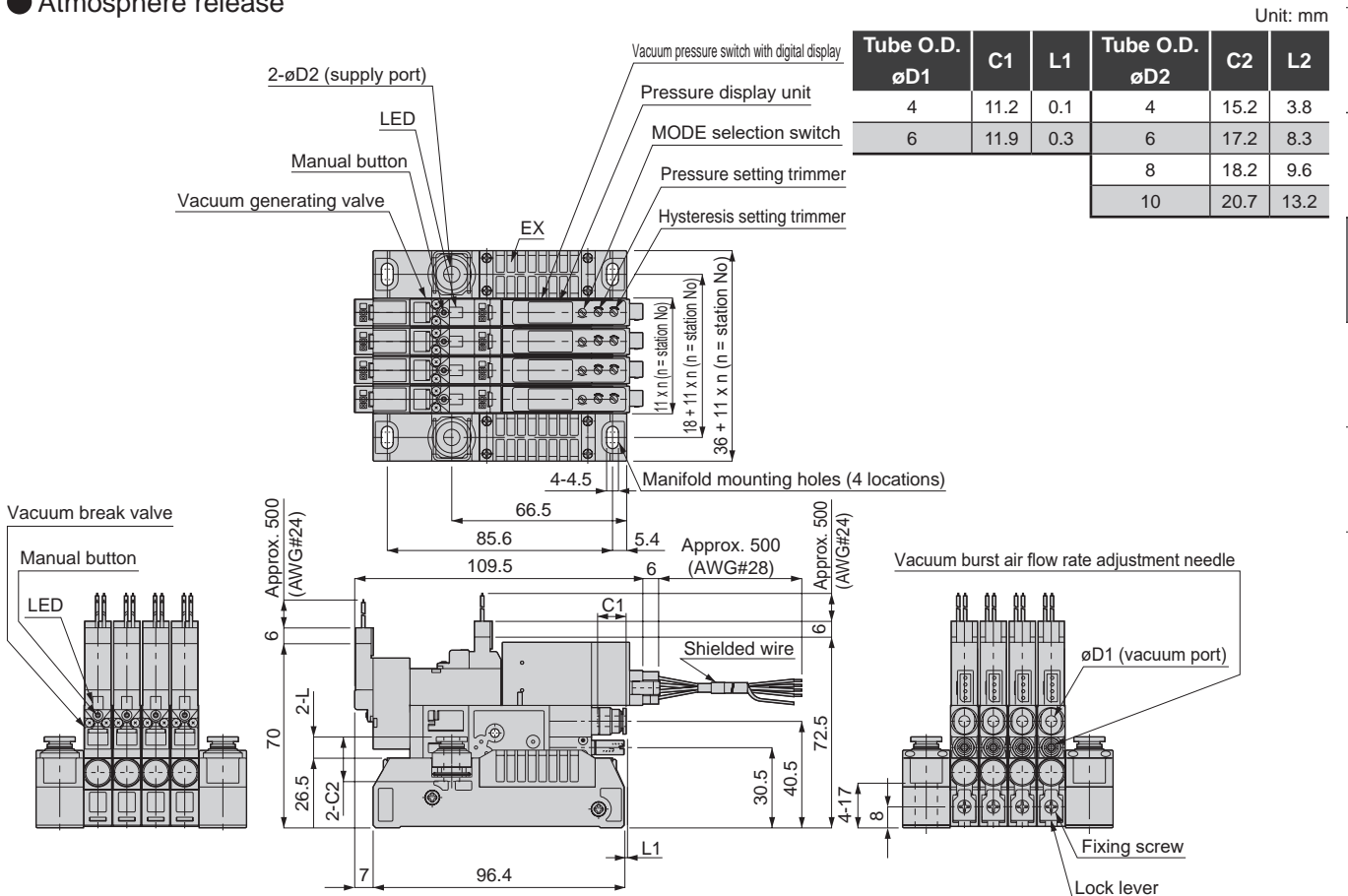

Ejector system

VSY

VSH/VSU
VSB/VSC

VSG

VSK
VSKM

VSJ
VSJM

VSN
VSNM

VSX
VSXM

VSQ

VSZM

Safety precautions

Refer to Intro Pages 15 and 16 for general precautions on vacuum system components.

! WARNING

- When operating the valve, make sure that the leakage current is no greater than 1 mA. Otherwise, there is a risk of malfunctions caused by leakage current.
- If energization to the pilot valve continues for long periods, heat is generated from the coil. Heat could cause burns and impact peripheral devices. Consult with CKD if continuously energizing for long periods.
- For the self-hold (VSX-□□D...), when resupplying after the pilot air supply is stopped (including the first use after shipment), the position of the switching valve is in neutral. When re-supplying the pilot air, be sure either to input a signal to the pilot valve or to perform switching manually.
- When using the DIN rail, if vibration or impact may be applied to the product, use commercially available DIN rail fixing brackets on both sides for safety and install securely.
- When removing or attaching the unit from/to the manifold, first stop the supply air and securely exhaust the residual pressure.
- When installing the unit in the manifold, insert the lock lever to the end and fix it securely with screws. Vibration may cause the lock lever to come off and the unit to pop out.

! CAUTION

- Do not apply high tensile force or bending force to the pilot valve or vacuum pressure switch lead wire. It could cause disconnection or damage to the connector unit.
- Compressed air contains a large amount of drainage (water, oil oxides, tar, foreign matter). Since drain significantly reduces product performance, dehumidify with after-cooler and dryer to improve air quality.
- Do not use a lubricator.
- As rust inside the piping may cause malfunctions, be sure to insert a filter of 5 μm or less in front of the supply port. In addition, flushing of pipes is recommended before use and at appropriate intervals.
- Avoid using in corrosive gas or flammable gas atmospheres. Do not use as the working fluid.
- When replacing the cartridge fitting of the supply (PS, PV) port, remove the deposits from the seal and then securely insert the stop pin.
- When replacing the cartridge fitting of the vacuum (V) port, remove the deposits on the seal part after checking that the window packing has not fallen off and securely fix the screws with the prescribed tightening torque.
- When mounting the unit in the manifold, check that there is no fallout or protrusion of the O-ring of air supply (vacuum supply) and exhaust (air supply) ports.
- Set the piping (supply port) diameter, pipe length and other components so that sufficient effective cross-sectional area can be secured for the vacuum port.
- In the manifold vacuum ejector, when an operating ejector and an inoperative ejector are mixed, exhaust air is led into the ejector not in operation and output from the vacuum port. For example, lightweight workpieces may be blown away. Therefore, do not use under conditions which might affect the workpiece.

Ejector system

VSY

VSH/VSU
VSB/VSC

VSG

VSK
VSKM

VSJ
VSJM

VSN
VSNM

VSX
VSXM

VSQ

VSZM

Manifold safety precautions

■ Increased manifold stations may cause degraded performance or malfunction due to the following reasons. Contact CKD for details.

1. Decreased vacuum performance due to insufficient supply air

- Countermeasure :
- (1) Confirm supply air capacity, etc.
 - (2) Piping length as short as possible
 - (3) Larger fitting size
 - (4) For one-side supply, supply from both sides of the manifold

2. Exhaust port capacity becomes insufficient, and the vacuum performance is degraded or exhaust air is emitted from the vacuum port of another station.

→ The number of stations for which performance can be maintained when used as a manifold depends on the nozzle size, vacuum performance, etc. Contact CKD for details.

Cause : For the silencer (atmospheric release), exhaust resistance increases and performance deteriorates due to the insufficient silencer capacity.

- Countermeasure :
- (1) Use individual exhaust for each station. (custom order)
 - (2) Avoid places that interfere with the exhaust.
 - (3) Reduce the station No.

Cause : For the common exhaust type, the performance deteriorates due to the large piping resistance.

- Countermeasure :
- (1) Shorten the pipe length as much as possible.
 - (2) Increase the exhaust fitting size.
 - (3) Use individual exhaust for each station. (custom order)
 - (4) Reduce the station No.

Usage methods

1. How to handle the vacuum pressure switch

(1) Pressure setting procedure

- (1) Energization (supply DC power after confirming the wiring.)
- (2) Set the MODE change-over switch to pressure setting mode (ME → S1 or S2, SW).
- (2)-2. (vacuum pressure switch with analog output only)
Turn the hysteresis setting trimmer (HYS) fully counterclockwise to set hysteresis to minimum.
- (3) Align to the desired setting value by turning the pressure setting trimmer (S1 or S2, SW) with a small screwdriver, etc.
- (4) Set the MODE change-over switch to pressure display mode (ME), apply pressure and confirm actual operation.
 - For vacuum pressure switch with 2-point switch output:
Switch output 1 (S1) : Operation indicator lamp (red LED) turns ON at set pressure or greater.
Switch output 2 (S2) : Operation indicator lamp (green LED) turns ON at set pressure or greater.
 - For vacuum pressure switch with analog output:
Switch output (SW) : Operation indicator lamp (red LED) turns ON at set pressure or greater.

(2) Hysteresis setting

- (1) Hysteresis can be adjusted by the hysteresis setting trimmer (HYS).
- (2) Hysteresis adjusting range is approx. 0 to 15% F.S. Hysteresis increases when the trimmer is rotated clockwise.
- (3) Hysteresis confirmation
Set the MODE change-over switch to pressure display mode (ME), and gradually increase/decrease the pressure so that it will be over and under the set pressure. Then, read the values displayed when the operation indicator lamp turns ON and OFF. The display value difference is the hysteresis.
[Hysteresis adjustment application examples]
· When the pressure is pulsating and the output cuts out at fine intervals, increase the hysteresis.
· When setting the allowable range of pressure drop.

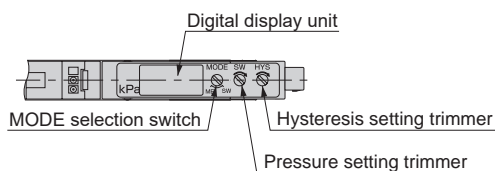

Vacuum pressure switch with digital display
(Analog output, with switch output type)

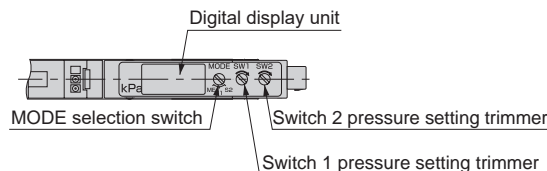

Vacuum pressure switch with digital display
(type with 2-point switch output)

Usage methods

(3) How to wire

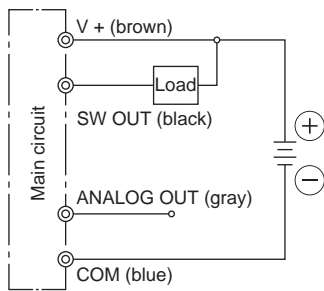

Vacuum pressure switch with LED display
(Analog output, with switch output type)

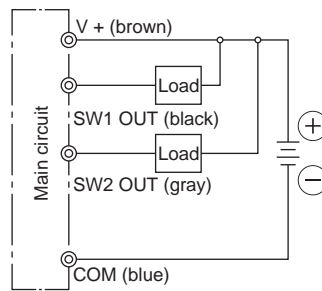

Vacuum pressure switch with LED display
(type with 2-point switch output)

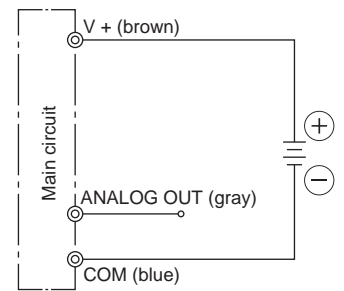

Vacuum pressure switch with
analog output

Ejector system

VSX

VSH/VSU
VSB/VSC

VSG

VSK
VSKM

VSJ
VSJM

VSN
VSNM

VSX
VSXM

VSQ

VSZM

2. Safety precautions for vacuum pressure switch

- (1) Do not use in atmospheres or gases containing corrosive substances. It risks damaging the switch.
- (2) Do not perform wiring or usage that would introduce noise (surge), etc. It risks damaging the switch.
- (3) Do not use in flammable or explosive gases, liquids, or atmospheres. This may cause fire or explosion, as the product does not have an explosion-proof structure.
- (4) Avoid using in places where the product is exposed to dripping water, oil, dust, etc. This may cause malfunction, as the product does not have a drip-proof structure.
- (5) Do not use where the heat generated exceeds the operating temperature range. It risks damaging the switch.
- (6) Make sure to turn the power OFF before wiring. During wiring, check the lead wire color and do not short-circuit the output terminal and power supply terminal or COM terminal. Short-circuiting could cause switch malfunction.
- (7) Do not apply high tensile force or bending force to the connector cable. It could cause disconnection or damage to the connector unit.
- (8) The performance will not change even if pressure of about 0.5 MPa is instantaneously applied, but do not apply pressures of 0.2 MPa or greater during vacuum burst. If constantly applied, it could damage the switch.
- (9) When setting the pressure and hysteresis, use a small screwdriver and gently rotate within the rotation range of the trimmer, without applying excessive force. If excessive force is applied during adjustment, it could damage the trimmer and base.
- (10) Use a stable DC power supply.
- (11) To connect to an output terminal or power supply terminal (relay, solenoid valve, etc.), install a surge voltage absorption circuit. Avoid usage where current exceeds 80 mA.
- (12) When using a unit power supply such as switching power supply, ground the F.G. (frame ground).
- (13) Do not short-circuit the output terminal (black/gray lead wire) with other terminals.
- (14) Do not apply strong external impact or excessive force to the switch body.

3. How to adjust vacuum burst air flow rate

- The vacuum burst air flow rate is decreased by turning the vacuum burst air flow adjustment needle to the right (clockwise) and increased by turning it to the left (counterclockwise). After adjusting, securely tighten the lock nut with tightening torque of 0.1 to 0.2 N·m.

* Be sure to use an appropriate flathead screwdriver for adjusting the vacuum burst air flow rate.

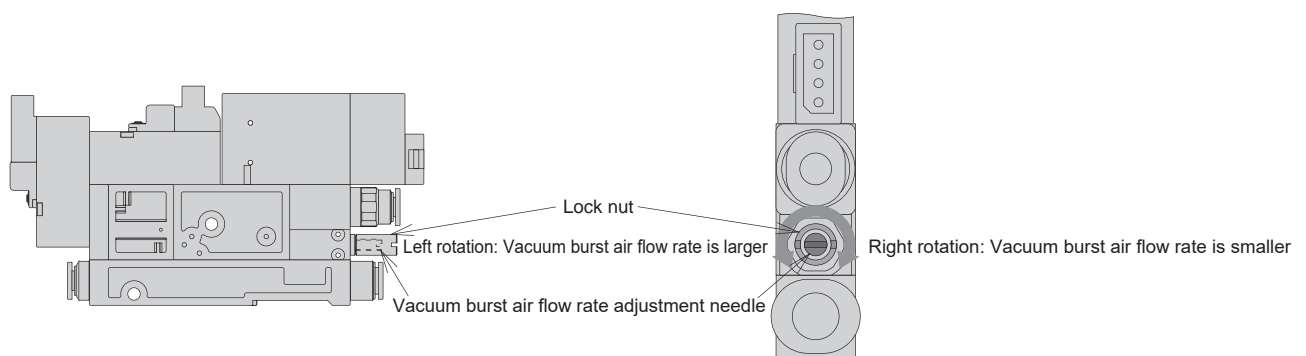

Usage methods

4. How to replace the filter element

- To replace the filter element, remove the piping of the vacuum port, loosen the screw inside the fitting (inside the tube insertion port) using a Phillips screwdriver (Note) with O.D. of 2.5 mm or less, remove the vacuum port and replace. After replacing the filter element and checking that the filter packing has not fallen out, attach the filter element and filter window to the vacuum port and then fasten the vacuum port to the main body. Tighten the screw securely with tightening torque of 0.1 to 0.15 N·m. (Note) Ensure that the locking claw and the driver do not interfere with one another. Scratches or deformation of the lock claw may decrease the tensile strength of the tube.

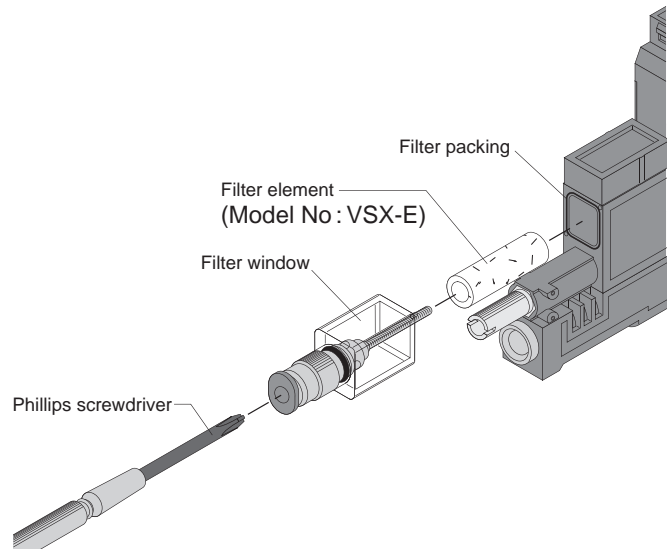

5. How to replace the silencer element

- When replacing the direct mount silencer element, use a flathead screwdriver to remove the stop pin first. After replacing the silencer element, securely insert the stop pin.

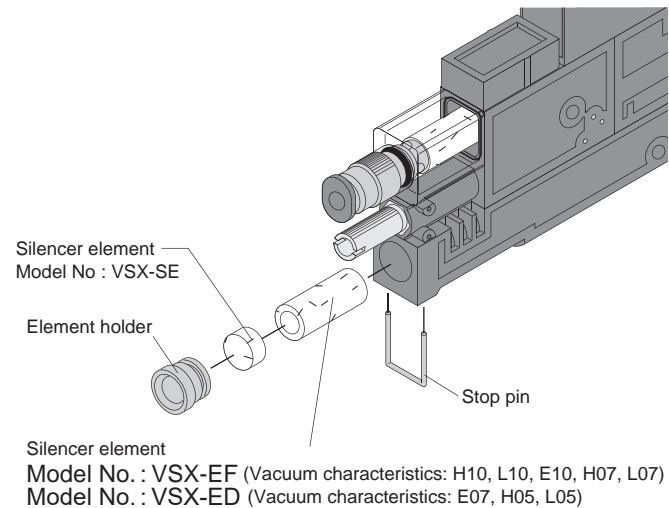

- To replace the DIN rail mount silencer element, use an appropriate Phillips screwdriver to remove the DIN rail fixing screws. Next, use a flathead screwdriver to remove the stop pin before replacing. After replacing the silencer element, securely insert the stop pin and fix the DIN rail fixing screws. (Recommended tightening torque: 0.1 to 0.15 N·m)

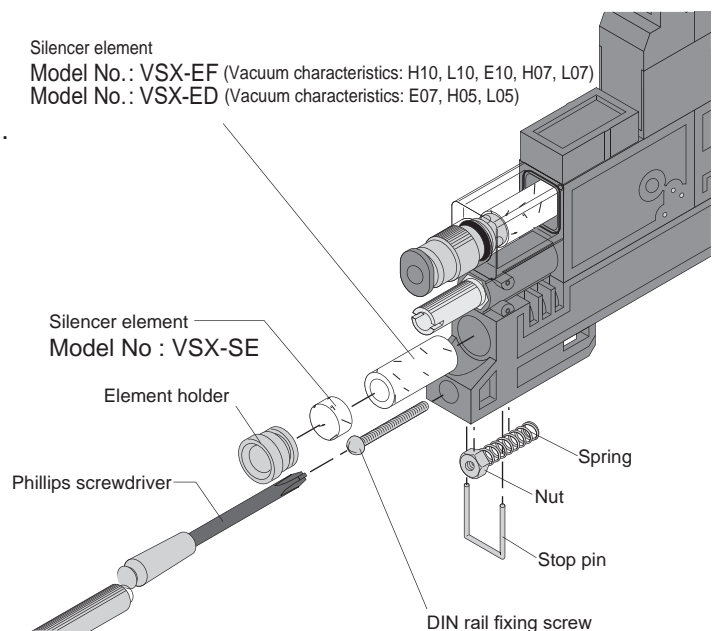

Ejector system

VSX

VSH/VSU
VSB/VSC

VSG

VSK
VSKM

VSJ
VSJM

VSN
VSNM

VSX
VSXM

VSQ

VSZM

Usage methods

6. Removal and cleaning of nozzle and diffuser

- Remove the silencer element and fixing screws (see figure below) and pull out the diffuser using needle-nosed pliers. To prevent the nozzle from popping out, cover the exhaust port with cushioning material such as a sponge and supply the air for vacuum generation (*5). Since the nozzle will pop out due to the force of air, remove the cushioning material and take out the nozzle.

Remove the deposits on the nozzle, diffuser bore and seal by air blow or wiping (*6).

Assemble the nozzle on the diffuser and supply to the body so that the nozzle does not come off. Push the diffuser in (see figure below) until the diffuser groove aligns with the hole of the fixing screw, and tighten the fixing screw with tightening torque of 0.25 to 0.35 N·m. For mounting the silencer element, refer to "How to replace the silencer element".

(*5) [Warning] Do not point the nozzle outlet at a person while supplying air to the product. The nozzle may pop out and cause injury.

(*6) Do not damage the nozzle, diffuser bore or seal. This will cause performance degradation.

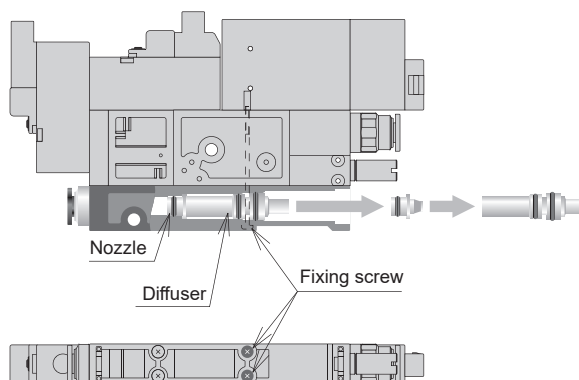

7. How to replace the manifold mounting unit

■ How to remove the unit

- Stop the supply air and exhaust the residual pressure.
- Turn the power OFF and remove the wiring.
- Use a suitable Phillips screwdriver to remove the fixing screw.
- Pull out the lock lever fully using a flathead screwdriver and remove the unit.

■ How to install the unit

- Check that the O-ring of the supply port and exhaust port has not fallen out.
- Pull out the lock lever fully to the front and install the unit.
- Push the lock lever while pressing the unit from above and securely fix the lock lever with the lock lever fixing screw.

(Fixing screw tightening torque: 0.15 to 0.2 N·m)

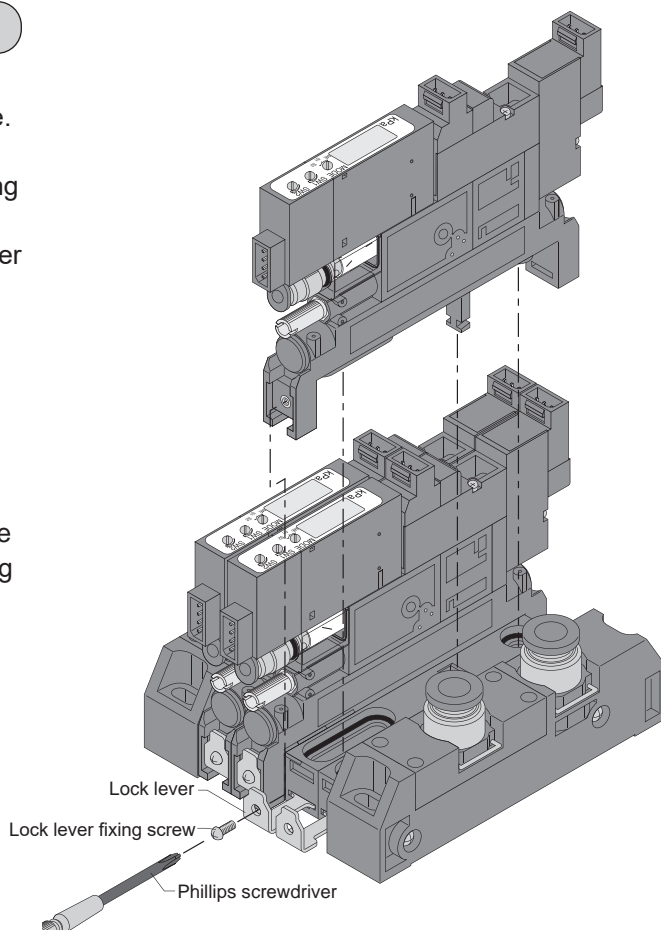

Ejector system

VSY

VSH/VSU
VSB/VSC

VSG

VSK
VSKM

VSJ
VSJM

VSN
VSNM

VSX
VSXM

VSQ

VSZM

8. How to replace the silencer element for manifold

■ How to remove silencer element

- Use a suitable Phillips screwdriver to remove the four tapping screws.
- Remove the element cover and replace the silencer element (Model No.: VSXPM-SE).

■ How to install silencer element

- Using a suitable Phillips screwdriver, tighten the four tapping screws with tightening torque of 0.3 to 0.4 N·m.

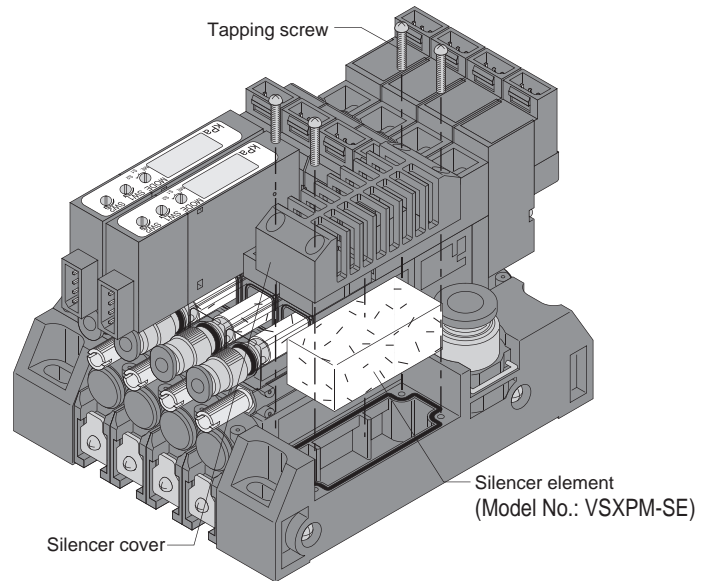

Ejector system

VSY

VSH/VSU
VSB/VSC

VSG

VSK
VSKM

VSJ
VSJM

VSN
VSNM

VSX
VSXM

VSQ

VSZM

Fixing method

(1) Direct mount

Tighten and fix with M3 screws using the fixing holes (2 places) on the resin body. (Refer to the dimensions for the fixing hole pitch.)

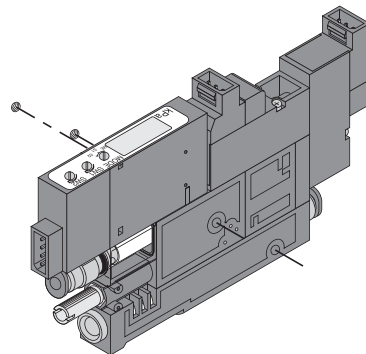

(2) DIN rail mount

Fit the product into the DIN rail and tighten the DIN rail fixing screw using a suitable Phillips screwdriver.

- If vibration or impact may be applied to the product, install commercially available DIN rail fixing brackets on both sides of the product and fix securely.

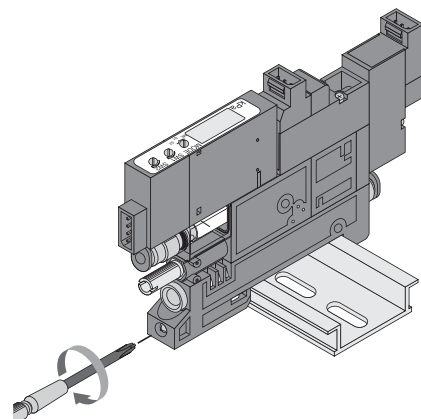

Ejector system

VSJ

VSH/VSU
VSB/VSC

VSG

VSK
VSKM

VSJ
VSJM

VSN
VSNM

**VSX
VSXM**

VSQ

VSZM

How to fill out VSXM mix manifold specifications sheet

● Mix manifold model No. (example)

VSXM- ^A Z ^B 00 ^C Z - ^D CX ^E 6 ^F 5 - ^G 3 - ^H 5 - ^I B

● Mix manifold specifications sheet (example)

Ejector system	Vacuum ejector model No.						Layout position										Quantity	
	A	B	C	D	E	I	1	2	3	4	5	6	7	8	9	10		
VSXM-	H	07	B	4	3	DW	<input type="radio"/>	<input type="radio"/>										2
VSXM-	E	07	B	6	3	DW			<input type="radio"/>		<input type="radio"/>							2
VSXM-	E	07	A	6		DA				<input type="radio"/>							1	
VSXM-																		
VSXM-																		

[For output port size only fitting mix specification]

● Mix manifold model No. (example)

VSXM- ^A H ^B 07 ^C B - ^D CX ^E 4 ^F 4 - ^G 3 - ^H 5 ^I DW

● Mix manifold specifications sheet (example)

VSG	Vacuum ejector model No.						Layout position										Quantity	
	A	B	C	D	E	I	1	2	3	4	5	6	7	8	9	10		
VSXM-	H	07	B	4	3	DW	<input type="radio"/>	<input type="radio"/>										2
VSXM-	H	07	B	6	3	DW			<input type="radio"/>	<input type="radio"/>	<input type="radio"/>							3
VSXM-																		
VSXM-																		
VSXM-																		

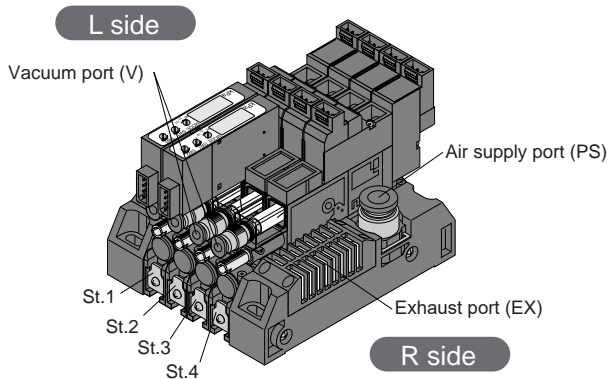

[When filling in]

- With vacuum port facing front, set piping positions in order from the left.
- Write the total quantity of product model No. specified in the required quantity field at the table far right.

VSXM mix manifold specifications sheet

Issued / /
 Company _____
 Contact _____
 Order No. _____

Contact _____ Quantity _____ Set _____ Delivery date / / _____
 Slip No. _____ Order No. _____

● Mix manifold model No.

VSXM- - - - -

A Vacuum characteristics *1, 2	
H	High vacuum/medium flow rate
L	Medium vacuum/large flow rate
E	High vacuum/low flow rate
Z	For mixed specs (indicate breakdown on specs sheet.)

B Nozzle diameter *1, 2	
05	ø0.5
07	ø0.7
10	ø1.0
00	For mixed specs (indicate breakdown on specs sheet.)

C Valve	
B	Normally closed
D	Self hold type
Z	For mixed specs (indicate breakdown on specs sheet.)

D Vacuum port (V)	
4	ø4 push-in fitting
6	ø6 push-in fitting
CX	For mixed fittings (indicate breakdown on specs sheet.)

E Air supply port (PS)	
4	ø4 push-in fitting
6	ø6 push-in fitting
8	ø8 push-in fitting
10	ø10 push-in fitting

F Exhaust port (EX)	
S	Atmospheric release with silencer
6	ø6 push-in fitting common exhaust
8	ø8 push-in fitting common exhaust
10	ø10 push-in fitting common exhaust

G Solenoid valve voltage	
1	100 VAC
3	24 VDC

H Manifold station No.	
2 to 10	2 to 10 stations

I Vacuum pressure switch specifications	
Blank	Without vacuum pressure switch
DW	With digital display, NPN output 2 points
DA	With digital display, NPN output 1 point + analog output
AO	Analog output
Z	For mixed specs (indicate breakdown on specs sheet.)

⚠ Precautions for model No. selection

- *1 : The combination of A E and B 05 cannot be selected.
- *2 : When A is Z, only B 00 can be selected.
When B is 00, only A Z can be selected.

● Mix manifold specifications sheet

Vacuum ejector model No. A B C D E I	Layout position										Quantity
	1	2	3	4	5	6	7	8	9	10	
VSXM- <input type="text"/> <input type="text"/> <input type="text"/> - <input type="text"/> - <input type="text"/> - <input type="text"/>											
VSXM- <input type="text"/> <input type="text"/> <input type="text"/> - <input type="text"/> - <input type="text"/> - <input type="text"/>											
VSXM- <input type="text"/> <input type="text"/> <input type="text"/> - <input type="text"/> - <input type="text"/> - <input type="text"/>											
VSXM- <input type="text"/> <input type="text"/> <input type="text"/> - <input type="text"/> - <input type="text"/> - <input type="text"/>											
VSXM- <input type="text"/> <input type="text"/> <input type="text"/> - <input type="text"/> - <input type="text"/> - <input type="text"/>											

Ejector system
 VSQ
 VSQ
 VSJ
 VSJM
 VSN
 VSNM
 VSK
 VSKM
 VSG
 VSG
 VSHVSU
 VSBVSC
 VSY
 VSX
 VSXM