

INSTRUCTION MANUAL
SERIAL TRANSMISSION TYPE
T6C0, T6C1

- Please read this instruction manual carefully before using this product, particularly the section describing safety.
- Retain this instruction manual with the product for further consultation whenever necessary.

For Safety Use

To use this product safely, basic knowledge of pneumatic equipment, including materials, piping, electrical system and mechanism, is required (to the level pursuant to JIS B 8370 Pneumatic System Rules).

We do not bear any responsibility for accidents caused by any person without such knowledge or arising from improper operation.

Our customers use this product for a very wide range of applications, and we cannot keep track of all of them. Depending on operating conditions, the product may fail to operate to maximum performance, or cause an accident. Thus, before placing an order, examine whether the product meets your application, requirements, and how to use it.

This product incorporates many functions and mechanisms to ensure safety. However, improper operation could result in an accident. To prevent such accidents, **read this instruction manual carefully for proper operation.**

Observe the cautions on handling described in this manual, as well as the following instructions:

CAUTION :

- Incorrect address settings of serial transmission slave stations could cause the solenoid valve and the cylinder to malfunction.
Before using the product, check the set address of the slave stations.
- For operation of serial transmission slave stations, read the communication system operation manual carefully.
- Do not touch electric wiring connections (exposed live parts) : this will cause an electric shock. During wiring, keep the power off. Also, do not touch these live parts with wet hands.

INDEX

T6C0, T6C1

Serial Transmission Type

Manual No. SM-301315-A

1. PRODUCT	
1.1 General outline of the system	3
1.2 Structure of the System	5
1.3 Specifications	6
1.4 Part Name and Description	8
1.5 Slave station for valve	9
1.6 Mounting of Slave station for valve	11
2. CAUTION	14
3. OPERATION	
3.1 Switch setting	14
3.2 Correspondence between Output Nos. and internal connector Nos.	16
3.3 Correspondence between Output Nos. and Valve solenoid Nos.	16
3.4 Programming	17
4. INSTALLATION	
4.1 Wiring	18
5. MAINTENANCE	
5.1 Troubleshooting	20

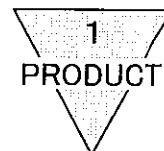

1. PRODUCT

1.1 General outline of the system

1) T6C1·T6C0

This solenoid valve T6C1·T6C0 is a manifold solenoid valve incorporating a slave station (OPP3-1C·0C), which can be connected to the CompoBus/S of Omron's programmable controllers (PLC) C200HX/HG/HE (hereafter referred to as SYSMAC α), C200HS, and CQM1 series.

- (1) The PLC and manifold solenoid valve can be connected only with one cable. The can reduce the number of wiring work steps.
- (2) Up to 16 manifold solenoid valves with the slave station can be connected to one master unit, allowing distributed control in units of 16 or 8 points. (The maximum length of main line is 100 m.)
- (3) The source of power for unit and valve can be installed individually and each unit has a monitor LED indicator.
- (4) If the communication error occurs, holding or clearing of the output signal is selected using the output mode setting switch.

2) CompoBus/S

CompoBus/S is one of remote I/O systems of Omron's programmable controllers SYSMAC α , C200HS, and CQM1 series, and provides the following features.

- (1) One cable connection saves the wiring work.
The master station and slave station, as well as two slave stations are connected only with one cable. Additionally, use of 4-wire special flat cable makes it possible to supply the power for communication to the slave station through this cable. This may greatly reduce the floor wiring. Additionally, the branch line can also be easily branched from the main line with special connector.
- (2) A high speed communication cycle time of 0.5 ms is achieved.
Up to 16 slave stations and 128 input/output points are connected at a high speed communication cycle of 0.5 ms.
The system is applicable to even time critical FA fields.
- (3) The system can be configured freely by means of T branch method and multi-drop method.
T branch method and multi-drop method can be combined freely for wiring. This makes it possible to configure a system having a high degree of freedom corresponding to the floor structure. Additionally, two kinds of cables, VCTF cable and special flat cable, are provided. When using the special flat cable, the T-branch connector can be attached using one-touch operation.

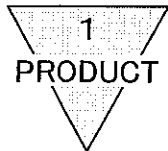

- (4) The maximum length of the main line is 100 m.
With the high speed communication achieved, the length of the main line can be extended to 100 m, ensuring high-speed I/O processing of input and output units in a wide area.
- (5) CompoBus/S can be started up easily.
CompoBus/S can be started up easily only by wiring the cables and making simple settings. It is also easy to replace the conventional remote I/O system with this system.
Faulty slave No. is indicated using the LED.
If any fault occurs in a slave station, the slave No. (node address) is displayed on the 4-digit LED on the master station, ensuring easy finding of faulty part. When using the master unit for C200HX/HG/HE or C200HS, the fault of the internal auxiliary relay is also displayed in detail.
- (6) A wide variety of slaves are provided.
A wide variety of input and output units, such as I/O and sensor terminals are provided as slave stations. Additionally, the BIT (bit chain) master station can also be used as slave station of CompoBus/S, ensuring free configuration of system corresponding to the application.

Note : Always thoroughly read Omron's User's Manuals. This manual basically describes T6C1·T6C0 and slave station OPP3-1C·0C. For details of Omron's programmable controllers SYSMAC α , C200HS, and CQM1 series and CompoBus/S, see relevant User's Manual.

For this manifold solenoid valve, read this instruction manual, as well as manuals described above to fully understand the functions and performance in order to operate the manifold solenoid valve properly.

For any further inquiries regarding CompoBus/S, contact with the manufacturer as listed below.

OMRON Corporation

Home page address : <http://www.omron.co.jp/>

1.2 Structure of the System

This system consists of a programmable controller main unit, master unit, solenoid valve T6C1 · T6C0, and auxiliary units.

- Combination of PLC and Master unit

Type of PLC	Type of master unit
C200HX/HG/HE C200HS, CS1	Model C200HW-SRM21-V1
CQM1H	Model CQM1-SRM21-V1
—	Model SRM1-C01/02-V2

- Fundamental structure of system

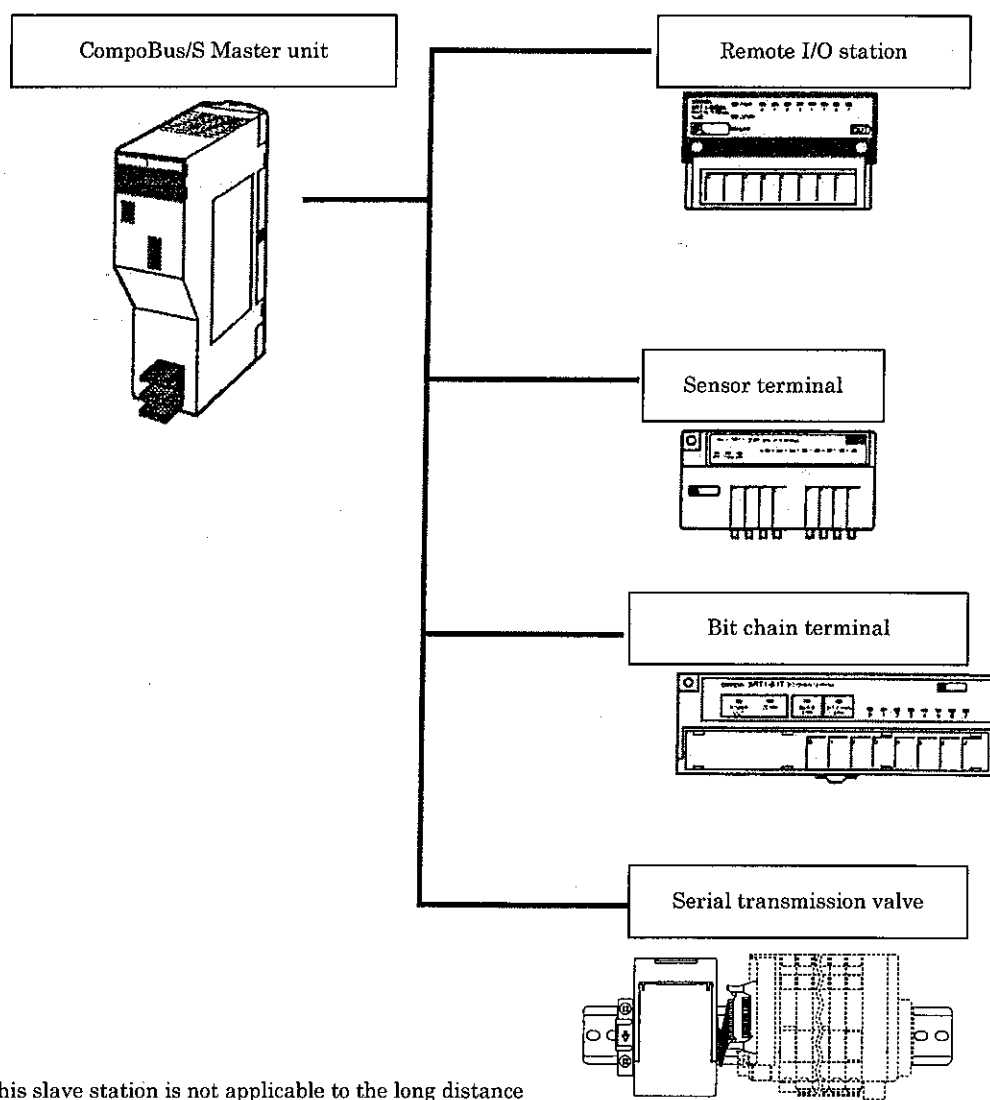

Note) This slave station is not applicable to the long distance communication mode. The slave station needs to be used in the high-speed communication mode.



1.3 Specifications

1) Electrical specifications

Item	Specification
Rated voltage (V)	DC24
Rated current (A)	0.025
Power consumption (W)	0.6
Voltage fluctuation range	+10%
Heat-proof class	B
Surge protection circuit	Zener diode type
Indicator	LED

2) Transmission specifications

Item	Specification												
Call processing	Special CompoBus/S protocol												
Transmission speed	750Kbit/s												
Modulation method	Base band method												
Encoding	Manchester coding method												
Error detection	Manchester code check, frame length check, and parity check												
Cable to be used	Vinyl cable VCTF JIS C 3306 : 2-core nominal cross section 0.75mm ² (Signal line × 2) (VCTF cable) Special flat cable : 0.75mm ² × 4 (signal line × 2 and power line × 2)												
Distance	<p>When the VCTF cable is used:</p> <table border="1"> <thead> <tr> <th>Length of main line</th> <th>Length of branch line</th> <th>Total length of branch lines</th> </tr> </thead> <tbody> <tr> <td>100m or less</td> <td>3m or less</td> <td>50m or less</td> </tr> </tbody> </table> <p>When the special flat cable is used:</p> <table border="1"> <thead> <tr> <th>Length of main line</th> <th>Length of branch line</th> <th>Total length of branch lines</th> </tr> </thead> <tbody> <tr> <td>30m or less</td> <td>3m or less</td> <td>30m or less</td> </tr> </tbody> </table> <p>However, even though the special flat cable is used, the length of the main line and the total length of branch lines can be set to 100 m or less and 50m or less, respectively if the number of connected slave stations is 16 or less.</p>	Length of main line	Length of branch line	Total length of branch lines	100m or less	3m or less	50m or less	Length of main line	Length of branch line	Total length of branch lines	30m or less	3m or less	30m or less
Length of main line	Length of branch line	Total length of branch lines											
100m or less	3m or less	50m or less											
Length of main line	Length of branch line	Total length of branch lines											
30m or less	3m or less	30m or less											

Note) The slave station needs to be used in the high-speed communication mode.

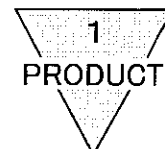

3) Slave station specification

Item		Specification
Power supply voltage (Unit side)		DC21.6V to 26.4V (DC24V \pm 10%)
Consumption current (Unit side)		OPP3-0C : 40mA or lower, OPP3-1C : 60mA or lower ((While all points are ON)
Power supply voltage (Valve side)		DC22.8V to 26.4V (DC24V \pm 10%, -5%)
Consumption current (Valve side)		15mA or lower (While all points are OFF.)
Insulation resistance		Between all external terminals in a lump and Case 20M Ω or more DC500VM
Withstand voltage		Between all external terminals in a lump and Case AC500V for 1 minute
Noise resistance		600Vp-p Pulse width 100nsce, 1 μ sec
Mechanical vibration proof	Durability	10Hz to 150Hz to 10Hz 1 octave / min. 15 sweeps in the 3 each axis of X, Y and Z while the half amplitude is 0.75mm or 10G whichever smaller.
	Wrong operation	10Hz to 150Hz to 10Hz 1 octave / min. 4 sweeps in the 3 each axis of X, Y and Z while the half amplitude is 0.75mm or 10G whichever smaller.
Mechanical shock proof		30G 3 directions 3 times
Ambient temperature		0 to 50°C
Ambient humidity		30 to 85%RH (No dew fall)
Working environment		No corrosive gas
Communication object		CompoBus/S (High-speed communication mode only)
No. of output points		OPP3-0C : 8 points, OPP3-1C : 16 points
Output insulation type		Photo coupler insulation
Max. load current		100mA/1 point
Leak current		0.1mA or lower
Residual voltage		0.5V or lower
Output model		NPN Transistor, Open collector output
Operating indication		LED (power lamp and communication status indicator only)
No. of monopolized stations		OPP3-0C : 8 points, OPP3-1C : 16 points

Note) This slave station is not applicable to the long distance communication mode.

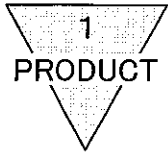

1.4 Part Name and Description

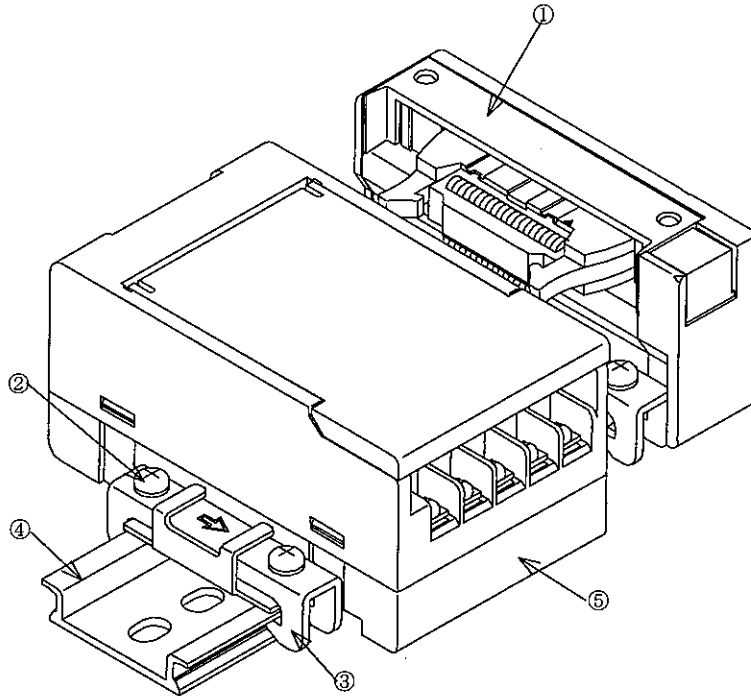

No.	Part name	Description
①	Electric component block	Includes and secures a printed circuit board with intermediate connectors.
②	Slave station mounting screw	Mounts the slave station no the DIN rail.
③	End retainer	
④	DIN rail	
⑤	Serial transmission unit block	Serves as a remote I/ O station in the communication network

1.5 Slave station for valve

1) Appearance

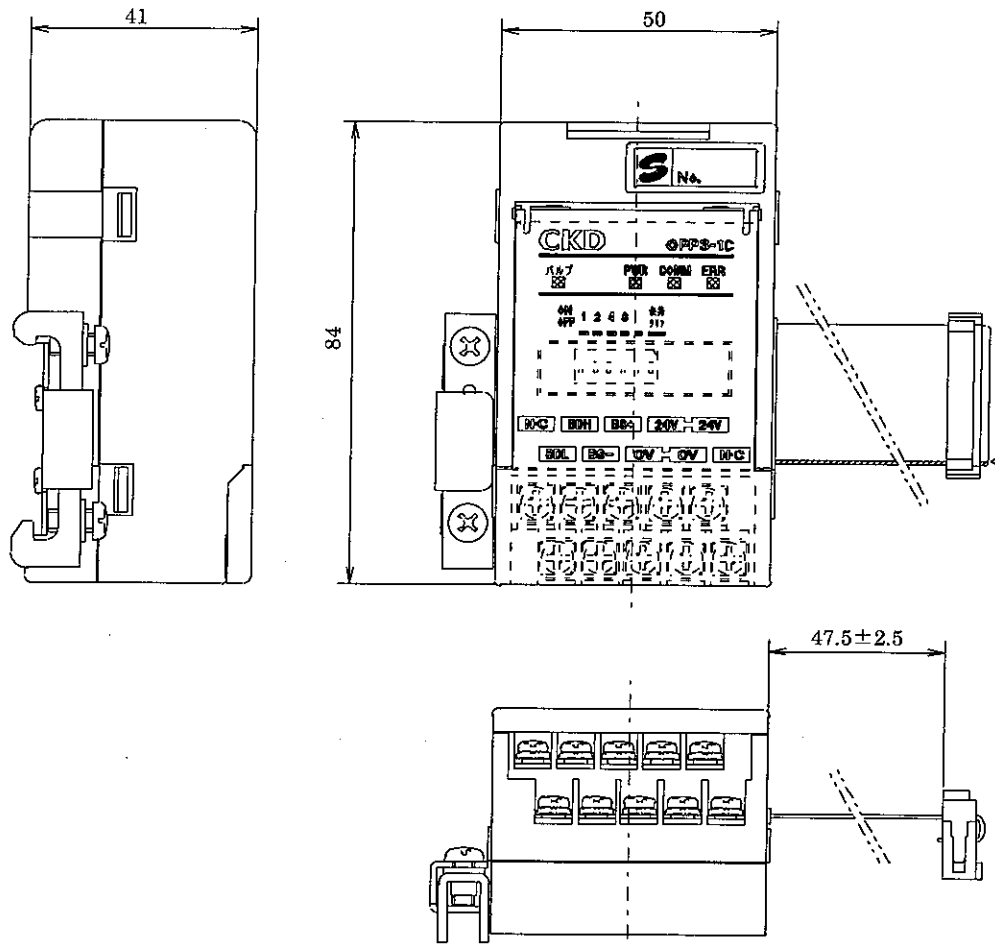



2) Indicators and switches on Slave station

- (1) Various LED lamps are installed in front of station to aid visual verification of operational conditions. Each function is printed on the sheet made of resin. The content of each function is posted in the table below. Make use of them during maintenance works or for verification of operation.

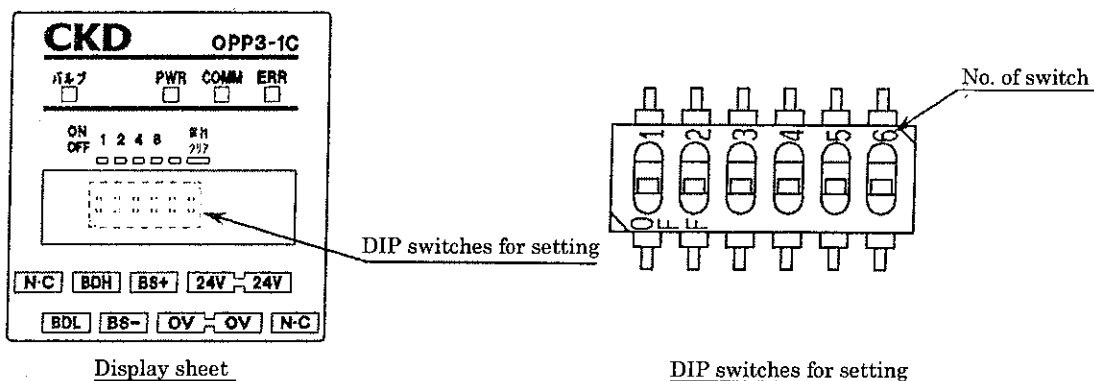

LED indications

Name of LED	Content of indication
Valve (green)	Lit when valve power is ON.
PWR (green)	Lit when unit power is ON.
COMM (orange)	Lit during normal communication. Off if the communication error occurs or the system is in the standby mode.
ERR (red)	Lit if the communication error occurs. Off during normal communication or if the system is in the standby mode.

Content of Setting

Name if switch	Content of Setting
Node address setting switch (Switch No.1 to 4)	Allocates the output contacts of the slave station to the channels of PLC.
Output mode setting switch (Switch No.6)	Selects to hold or clear the output data status if the communication error occurs.

※ Switch No. 5 is not used.

- (2) The node address of the slave station for the valve and output mode if the communication error occurs are set using the setting switches. (Refer to “Chapter 3. Operation”.) Be sure to set it before turning power to valve slave station ON.
- The cover of the slave station unit for the solenoid valve system can easily be opened and closed. Keep the cover closed except when you have to change switch positions or reconnect wires. If you keep the cover open unnecessarily, foreign matter may enter the circuit board causing an unexpected failure, or the cover may be broken by accidental contact. While the cover is open as you change switch positions or reconnect wires, be careful not to cause the entry of foreign matter.
 - Setting switch has been precisely built. Disorderly handling may cause damage of switch. To set station number, never touch internal circuit printed board.

1.6 Mounting of Slave station for valve

The slave station unit OPP3-1C·0C is normally secured by a retainer to the DIN rail (next to the solenoid valve manifold) and connected with the solenoid valve manifold by a connector (plug and socket). If you have to dismount the slave station unit from the DIN rail when you connect signal and power cables, for example, follow the procedure below:

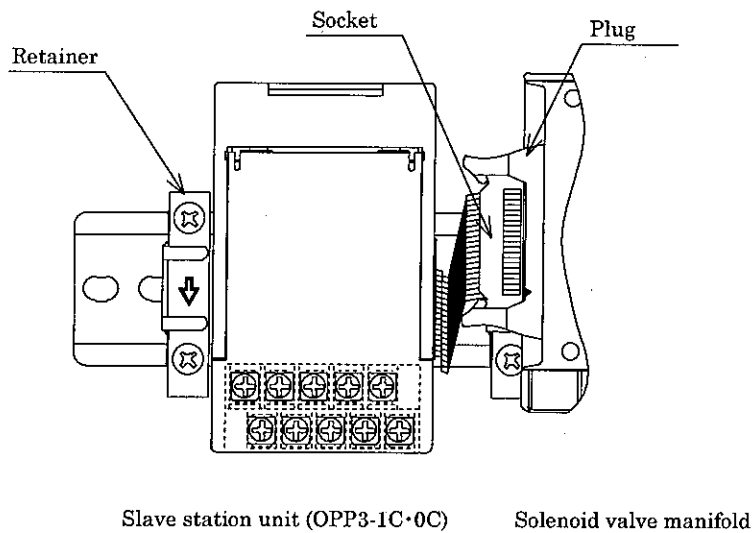

- 1) Spread the plug ends to remove the socket.
- ※ Spread the plug ends evenly.

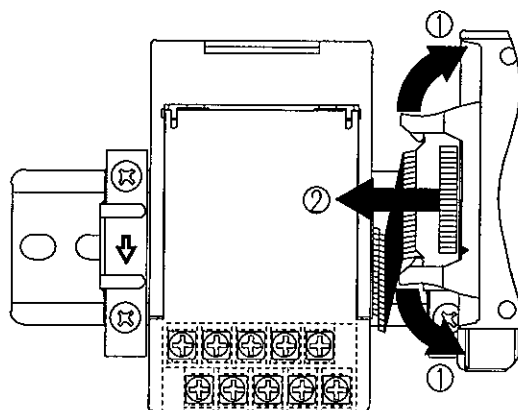

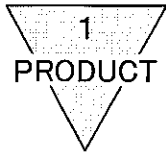

- 2) Slacken the two mounting screws and then slide the retainer until you can see a perfect hole ($\phi 2$ mm) in the retainer surface.

※ The retainer is unlocked when you can see the hole ($\phi 2$ mm); locked when you cannot.

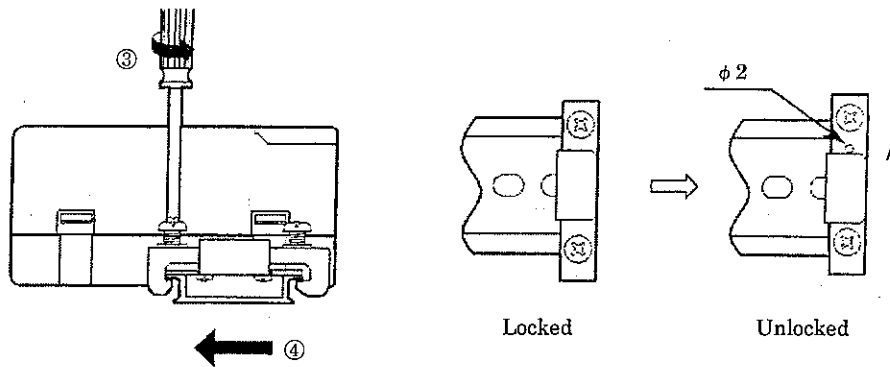

- 3) To disengage the slave station unit from the DIN rail, lift it at the rear end and pull toward the terminal block.

※ At this time, keep the retainer at the unlocked position by using your finger to hold the retainer at the end closer to you.

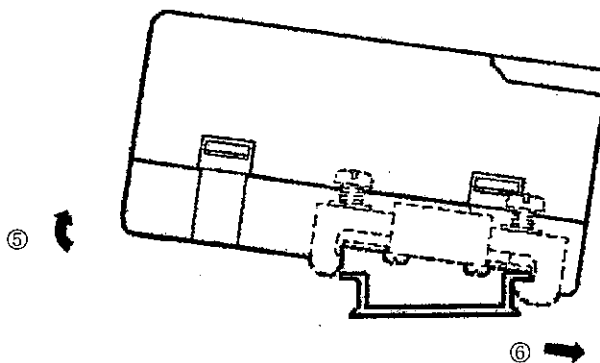

- 4) To reinstall the slave station unit, reverse the procedure; start with ⑥ and end with ①. Reverse the directions of arrows in the illustrations.

※ The distance between the slave station unit and the solenoid valve manifold depends on whether the connector is oriented vertically or horizontally. Be careful of this when reinstalling the slave station unit.

There are terminal blocks provided on the mounting device. Wiring connection to station is accomplished through these terminal blocks. Function of each terminal is printed on the face of station mounting device.

- Choose 6.6mm wide or less of M3 crimp type terminal metal piece and tighten it with torque of 0.3 to 0.5N · m.

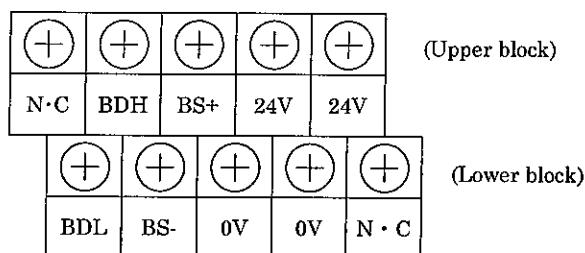

Terminal symbols and functions

Symbol	Function	Major objects to be connected
BD H BD L	Data terminal	To be connected to the communication terminals BD H and BD L of the master station or other slave station.
BS + BS - ※2	Power for Units	Apply source of power with less noise, such as DC24V±10%.
24V ※1 0V ※2	Power for valves	To be connected to the power supply (DV24V +10%, -5%) with less noise.
N · C	Not used	Do not use this terminal.

※1 24V terminals (two locations) on the upper stage are internally short-circuited. Additionally, 0V terminals (two locations) on the lower stage are also internally short-circuited. These terminals are used to supply the power to other I/O devices. However, note that the maximum allowable current to be flown into this slave station is 7A or less.

※2 Carefully carry out the wiring work while referring to the polarities of the power supply.

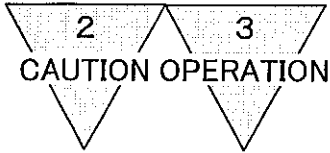

2. CAUTION

1) Output transmission delay time

The transmission delay time of the system may vary depending on the scanning time of the PLC main unit and/or devices connected to the master unit. For details, see the manuals for PLC main unit and master unit.

Solenoid valve responding time, of course, varies depending on model. It is advisable of referring to valve specification.

As for OFF time, there is another delay factor of approx. 20ms due to flywheel diode being used for surge absorbing circuit to valve slave station.

3. OPERATION

3.1 Switch setting

The setting switches are used to set two kinds of functions, node address and output mode if the communication error occurs.

Since different switches are used for different kinds of setup, you must correctly identify the switch to be used. Before changing the switch positions, be sure to cut the power.

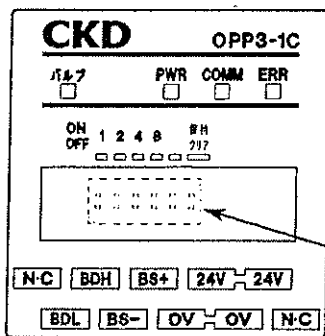

Display sheet

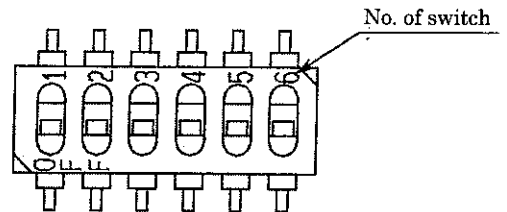

DIP switches for setting

(1) Setting the node address (Switch No. 1 to 4)

The node address of the remote I/O terminal to be connected to the slave station for this valve and the same signal line can be set in a range of #0 to #15. However, the I/O allocation of the slave unit may vary depending on the type of PLC main unit to be used and values set on the master unit. (For details of I/O allocation, see the User's Manual for CompoBus/S prepared by Omron.) The following table shows the correspondence between the node address and switch on this slave station.

※ To set a node address, set it so that it is not duplicated with the node address of other slave station.

If the node address is duplicate, the correct communication cannot be performed.

Additionally, if the 4-point mode is set on the master unit for CQM1, OPP3-1C (occupation of 16 points) cannot be used. (OPP3-0C (occupation of 8 points) can be used.)

※ A node address is set using the switch No. 1 to 4 as shown in the following table.

Node address	Switch No.			
	1(1)	2(2)	3(4)	4(8)
0	○	○	○	○
1	●	○	○	○
2	○	●	○	○
3	●	●	○	○
4	○	○	●	○
5	●	○	●	○
6	○	●	●	○
7	●	●	●	○

Node address	Switch No.			
	1(1)	2(2)	3(4)	4(8)
8	○	○	○	●
9	●	○	○	●
10	○	●	○	●
11	●	●	○	●
12	○	○	●	●
13	●	○	●	●
14	○	●	●	●
15	●	●	●	●

● : Switch is ON. ○ : Switch is OFF.

Note) Value in () corresponds to each switch (case marking).

(2) Setting the output mode (Switch No. 6)

The output status if the communication error occurs is set as shown below.

Switch No.6	Output data setting
ON	Hold
OFF	Clear

※ DIP switch No. 5 for setting is not used.



3.2 Correspondence between Output Nos. and internal connector Nos.

Those Numbers correspond as per table, posted below.

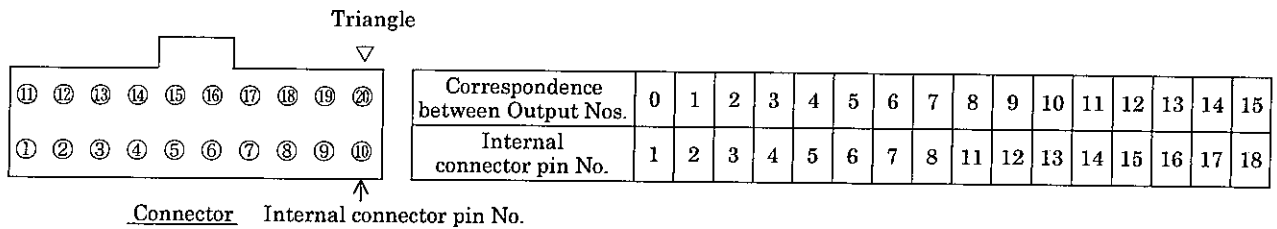

3.3 Correspondence between Output Nos. and Valve solenoid Nos.

- (1) Connector pin Nos. and manifold solenoid correspond with each other as per tables posted below. However, since OPP3-0C has 8 output points, valve station output Nos. 0 to 7 (8 points) become valid.
- (2) Manifold block number is allocated from leftmost block toward right while holding piping port facing to you, regardless the location of wiring block.

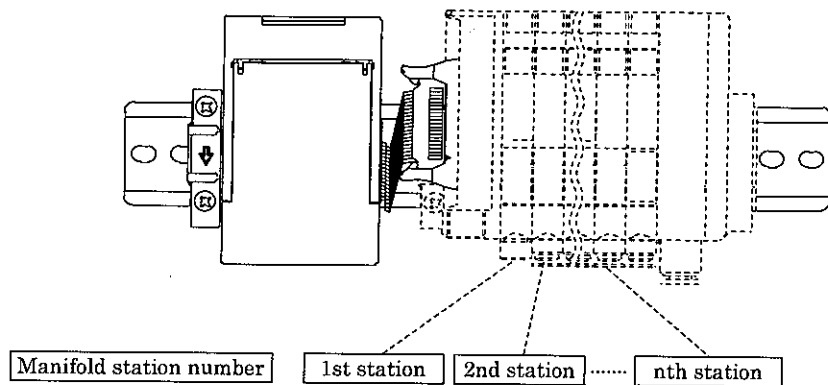

The pin array for the wiring method T6※ (example)

※ The numbers in valve No. 1a, 2a, 2b, ... indicate the station No.1, station No.2 and so on, while the alphabets (a) and (b) mean, respectively, the solenoid on the side (a) and the solenoid on the side (b). The maximum number of stations on the manifold differs among the models. Refer to the specifications of the model you selected.

Connector pin No.

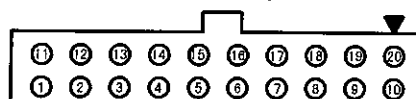

● For single solenoid valve stations only

<Standard wiring>

Pin No.	11	12	13	14	15	16	17	18	19	20
Valve No.	9a	10a	11a	12a	13a	14a	15a	16a	※2	※3
Pin No.	1	2	3	4	5	6	7	8	9	10
Valve No.	1a	2a	3a	4a	5a	6a	7a	8a	※2	※3

<Double wiring>

Pin No.	11	12	13	14	15	16	17	18	19	20
Valve No.	5a	※1	6a	※1	7a	※1	8a	※1	※2	※3
Pin No.	1	2	3	4	5	6	7	8	9	10
Valve No.	1a	※1	2a	※1	3a	※1	4a	※1	※2	※3

※1 : Not used ※2 : - electric power supply ※3 : + electric power supply

● For double solenoid valve stations only

Pin No.	11	12	13	14	15	16	17	18	19	20
Valve No.	5a	5b	6a	6b	7a	7b	8a	8b	※2	※3
Pin No.	1	2	3	4	5	6	7	8	9	10
Valve No.	1a	1b	2a	2b	3a	3b	4a	4b	※2	※3

※1 : Not used ※2 : - electric power supply ※3 : + electric power supply

● For mixed installation of single and double solenoid valve stations

<Standard wiring>

Pin No.	11	12	13	14	15	16	17	18	19	20
Valve No.	7a	7b	8a	9a	10a	10b	11a	11b	※2	※3
Pin No.	1	2	3	4	5	6	7	8	9	10
Valve No.	1a	2a	3a	3b	4a	4b	5a	6a	※2	※3

<Double wiring>

Pin No.	11	12	13	14	15	16	17	18	19	20
Valve No.	5a	※1	6a	※1	7a	7b	8a	※1	※2	※3
Pin No.	1	2	3	4	5	6	7	8	9	10
Valve No.	1a	※1	2a	※1	3a	3b	4a	4b	※2	※3

※1 : Not used ※2 : - electric power supply ※3 : + electric power supply

3.4 Programming

The programming of the slave station for this valve is made in the same manner as the remote terminal (output type) made by Omron. For details, see Omron's User's Manual.

4. INSTALLATION

4.1 Wiring

It is required to connect signal circuit with power line to make this model T6C0, T6C1 function. Erroneous connection causes not only malfunction but in some cases, vital transmission damage to this station including other related devices. Before starting the wiring work, see the manuals for Omron's programmable controllers SYSMAC α , C200HS, and CQM1 series, and CompoBus/S. Always carry out the wiring work in a correct manner.

1) Cable type and distance

The following shows the cable types and specifications.

Type	Specifications
VCTF cable (general purchase item)	Vinyl cable VCTF JIS C 3306 2-core nominal cross section: 0.75 mm^2 (Signal line $\times 2$) Resistance of conductor (at 20°C): $25.1 \Omega \text{ km}$
Special flat cable Model SCA1-4F10 (100m long)	Nominal cross section: $0.75 \text{ mm}^2 \times 4$ (signal line $\times 2$ and power line $\times 2$) Operating ambient temperature: 60°C or less

The following shows the distance of each communication cable.

Type	Length of main line	Length of branch line	Total length of branch lines
VCTF cable	100m or less	3m or less	50m or less
Special flat cable	30m or less	3m or less	30m or less

※ Even though the special flat cable is used, the length of the main line and the total length of branch lines are set to 100 m or less and 50 m or less, respectively if the number of connected slave stations is 16 or less
Note) This slave station is not applicable to the long distance communication mode.

2) Connecting the communication cable to this slave station

To connect the communication cable to this slave station, connect the BDH and BDL signal lines to the BDH and BDL terminals, respectively.

Additionally, to supply the unit power of the slave station, connect the BS+ (positive side of power) and BS- (negative side of power) lines to the BS+ and BS- terminals, respectively.

The following shows an example of connection to this slave station.

- VCTF cable

(a) Wiring the signal lines

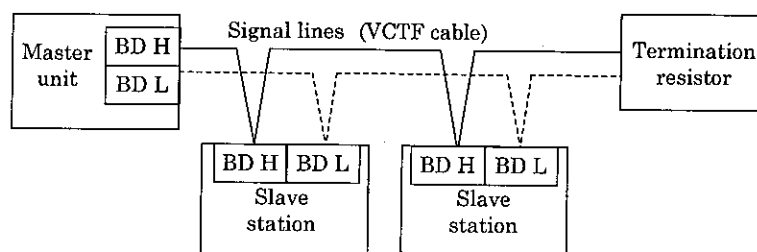

(b) Wiring the source of power

The power supply lines are connected by means of wiring method shown below.

① Common connection of Unit power and Valve power

② Wiring to enable Valve power to be turned On · Off.

③ Separate connection Unit power with Valve power

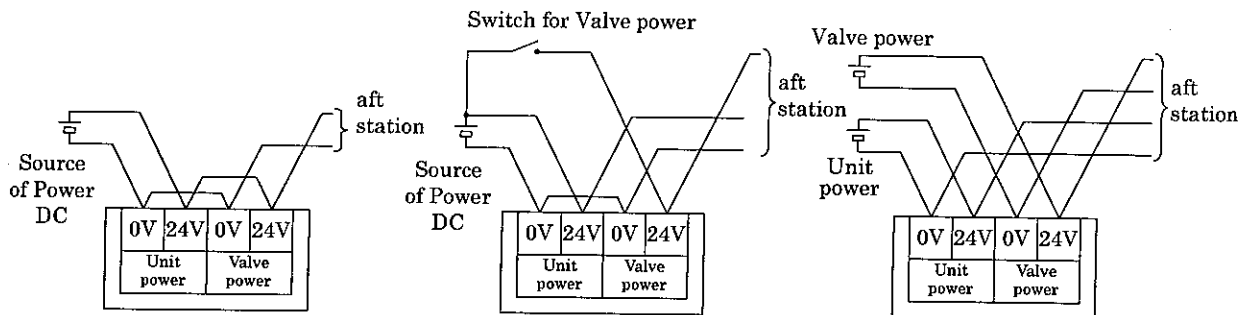

Note) When designing the system to supply power to duplex number of slave stations and remote I/O stations, choose and wire the source of power cord with a consideration of voltage drop. Secure ample voltage within rating by providing dual wiring, if necessary, to keep as small voltage loss of single system as possible or installing source of power near-by solenoid

• Special flat cable

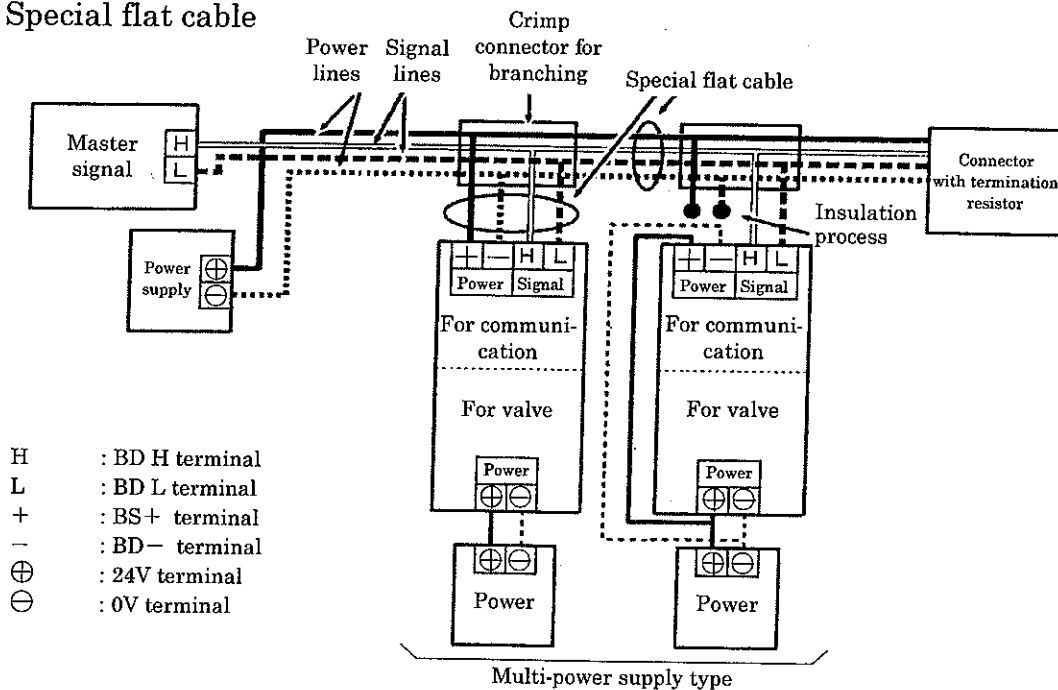

- H : BD H terminal
- L : BD L terminal
- + : BS+ terminal
- : BD- terminal
- ⊕ : 24V terminal
- ⊖ : 0V terminal

※ The signal lines of the special flat cable are determined as shown below.
If the power is not supplied through this cable, the BS+ and BS- power lines need to be insulated.

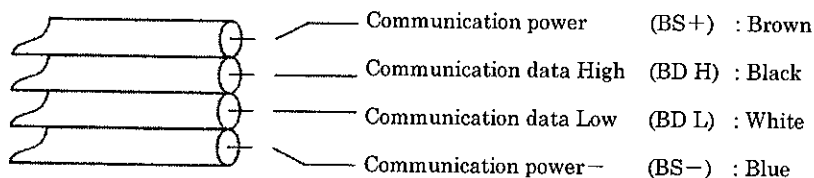



5. MAINTENANCE

5.1 Troubleshooting

Troubleshooting should address the entire system rather than a particular slave station. The same LED indicators as those on the remote I/O terminal made by Omron are provided on the slave station for this valve. According to these indications and those on the master unit, the cause of the error is located and appropriate remedy is taken. When taking the remedial action, see Chapter 4, Maintenance, in Omron's User's Manual for CompoBus/S. Additionally, a valve LED specially designed for the slave station for the valve is also provided. If only this LED is off, check the voltage supplied to the valve and power cable connection.

Meanings of LED indicators

Indicator	Name	Color	Status	Meaning
PWR (POWER OUT)	Power	Green		Communication power is being supplied.
			●	Communication power is not turned ON.
COMM	Communication	Yellow		During normal communication
			●	Communication error occurs or system is in the standby mode.
ERR (BUS/S ERR)	Communication error	Red		Communication error occurs.
			●	During normal communication or system is in the standby mode.

: Lit ● : Off

List of errors and alarms

Item	LED status			Cause of error	Remedy
	PWR	COMM	ERR		
Unit power OFF	●	●	●	Unit power is turned OFF.	Turn ON the unit power.
Area duplication	⊗	●	⊗	When the master unit for CQM1 is used and the number of occupied points per node address is set at the 4-point mode, the area is duplicated by slave stations. If this occurs, the communication is stopped.	Check the area of the 8-point slave station, where the error occurs. Eliminate the duplication with other slave station and turn ON the power to the master unit and PLC main unit.
Address over	⊗	⊗	●	When the master unit for CQM1 is used and the number of channels occupied by the PLC main unit is 2 or 4, a disable address is set in a node address of 0 to 7.	Check the LED indicator on the master unit and correct the node address to a level within the set range.
Out of node address range	⊗	●	●	When the master unit for CQM1 is used, a node address ranging from 8 to 15 is set.	Check the LED indicator on the master unit and correct the node address to a level within the set range.
Communication error	⊗	●	⊗	Communication error occurs in the slave station communicating the data, and then the communication fails.	Check the LED indicator on the master unit and remove the cause of the communication error.
Master power OFF	⊗	●	—	Master power is OFF.	Turn ON the master power.

⊗ : Lit ● : Off — : Unknown

The node address of the slave station where the error occurs is displayed in the status information (only master unit for C200HX/HG/HE and C200HS) or on the LED indicator of the master unit.