

INSTRUCTION MANUAL

OIL MIST FILTER

M~~×~~000 SERIES

HIGH PERFORMANCE OIL MIST FILTER

MX~~×~~000 SERIES

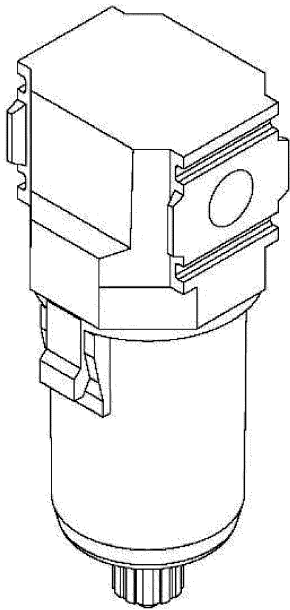

- Please read this instruction manual carefully before using this product, particularly the section describing safety.
- Retain this instruction manual with the product for further consultation whenever necessary.

Ver. 3

CKD Corporation

Safety precautions

When designing and manufacturing a device using CKD products, the manufacturer is obligated to manufacture a safe product by confirming safety of the system comprising the following items:

■ Device mechanism

■ Pneumatic or water control circuit

■ Electric control that controls the above

It is important to select, use, handle, and maintain the product appropriately to ensure that the CKD product is used safely.

Observe warnings and precautions to ensure device safety.

Check that device safety is ensured, and manufacture a safe device.



1. **This product is designed and manufactured as a general industrial machine part. It must be handled by someone having sufficient knowledge and experience.**
2. **Use this product within its specifications.**
Consult with CKD for details when using the product beyond the unique specification range, outdoors, or in the following conditions or environment: Additionally, the product must not be modified or machined.
 - ① Use for special applications requiring safety including nuclear energy, railroad, aviation, ship, vehicle, medical equipment, equipment or applications coming into contact with beverage or food, amusement equipment, emergency shutoff circuits, press machine, brake circuits, or for safeguard.
 - ② Use for applications where life or assets could be adversely affected, and special safety measures are required.
3. **Observe corporate standards and regulations, etc., related to the safety of device design and control, etc.**
ISO4414, JIS B 8370 (pneumatic system rules)
JFPS2008(principles for pneumatic cylinder selection and use)
Including High Pressure Gas Maintenance Law, Occupational Safety and Sanitation Laws, other safety rules, body standards and regulations, etc.
4. **Do not handle, pipe, or remove devices before confirming safety.**
 - ① Inspect and service the machine and devices after confirming safety of the entire system related to this product.
 - ② Note that there may be hot or charged sections even after operation is stopped.
 - ③ When inspecting or servicing the device, turn off the energy source (air supply or water supply), and turn off power to the facility. Discharge any compressed air from the system, and pay enough attention to possible water leakage and leakage of electricity.
 - ④ When starting or restarting a machine or device that incorporates pneumatic components, make sure that the system safety, such as pop-out prevention measures, is secured.
5. **Observe warnings and cautions on the pages below to prevent accidents.**

■ The safety cautions are ranked as "DANGER", "WARNING" and "CAUTION" in this section.

 **DANGER** :When a dangerous situation may occur if handling is mistaken leading to fatal or serious injuries, or when there is a high degree of emergency to a warning.

 **WARNING** :When a dangerous situation may occur if handling is mistaken leading to fatal or serious injuries.

 **CAUTION** :When a dangerous situation may occur if handling is mistaken leading to minor injuries or physical damage.

Note that some items described as "CAUTION" may lead to serious results depending on the situation. In any case, important information that must be observed is explained.

Precautions with regard to guarantee

● Guarantee period

The guarantee period of our product shall be one (1) year after it is delivered to the place specified by the customer.

● Guarantee coverage

If any failure for which CKD CORPORATION is recognized to be responsible occurs within the above warranty period, a substitute or necessary replacement parts shall be provided free of charge, or the product shall be repaired free of charge at the plant of CKD CORPORATION.

However, the guarantee excludes following cases:

- ① Defects resulting from operation under conditions beyond those stated in the catalogue or specifications.
- ② Failure resulting from malfunction of the equipment and/or machine manufactured by other companies.
- ③ Failure resulting from wrong use of the product.
- ④ Failure resulting from modification or repairing that CKD CORPORATION is not involved in.
Failure resulting from causes that could not be foreseen by the technology available at the time of delivery.
- ⑥ Failure resulting from disaster that CKD is not responsible of.

Guarantee stated here covers only the delivered products. Any other damage resulting from failure of the delivered products is not covered by this guarantee.

● Confirmation of product compatibility

Our customer shall be responsible of confirming compatibility of our product used in our customer's system, machinery or device.

【 INDEX 】

1. UNPUCKING	4
2. INSTALLATION		
2.1	Installation Environment 4
2.2	Piping 6
2.3	Wiring of differential pressure switch 8
3. PROPER OPERATION		
3.1	Important Safety Instructions 9
3.2	Installation of pressure differential detection 10
3.3	Installation 12
4. MAINTENANCE		
4.1	Periodic Inspection 13
4.2	Draining Out the Accumulated Sluge 14
4.3	Maintenance 14
4.4	Replacement of Filter Mantle (Element) 15
4.5	Expendable and Replacement Parts 16
5. TROUBLE SHOOTING	17
6. HOW TO ORDER & PRODUCT SPECIFICATIONS		
6.1	Product Specifications 18
6.2	Differential pressure switch specifications 19
6.3	Option mass table 19
6.4	How To Order 20

1. UNPACKING

 CAUTION	To prevent foreign matter from entering the product, unpack the product just before piping starts.
--	--

- (1) Make sure that the model number indicated on the product matches with what you have ordered.
- (2) Check the exterior of the product for damage.

2. INSTALLATION

2.1 Installation Environment

 WARNING	<p>plastic bowl</p> <p>These parts are made of polycarbonate, and cannot be used in environments containing synthetic oil, organic solvents, chemicals, coolant, screw locking agent, leak detection solutions, or hot water, etc., or where these substances may come in contact with them.</p> <p>Refer to page 5 for details on bowl chemical resistance.</p>
--	--

 CAUTION	<ol style="list-style-type: none"> a) Avoid installing this product where it is subject to ultraviolet rays. b) Prevent installation where the product is exposed to a direct sunlight. c) Avoid installation at places where there is excessive vibration or impact.
---	--

(1) Avoid using this product under the following conditions.

- Avoid using the product outside the range of 5 to 60°C (5 to 30°C for the mantle option "X").
- The air may be frozen.
- The water drop or coolant is splashed onto the product.
- The humidity is high and the temperature changes largely, causing dew condensation.
- Sea breeze or seawater is splashed onto the product.
- Avoid using the product in an atmosphere containing corrosive gas.
- Avoid using the product in a dusty atmosphere.
- Avoid using the product in an atmosphere where spluttering may occur.
- Do not expose the product to radiant heat if the product is installed near a heat source.
- Avoid using the product in an atmosphere where ozone is produced.

 WARNING	<p>The chemical resistance of plastic parts is shown below.</p> <ul style="list-style-type: none"> • Avoid using products in an atmosphere where chemicals are contained in compressed air, the atmosphere, or where they could adhere to parts. • Use in the above state could lead to bowl damage and accidents. • Avoid using these types of chemicals or in an atmosphere containing these chemicals. • A metal bowl is available if these chemicals must be used.
--	--

Types of chemicals	Classification	Major chemical products	General example	Poly-carbonate	Nylon
Inorganic product	Acid	Hydrochloric acid, sulfuric acid, hydrofluoric acid, phosphoric acid, chromic acid, etc.	Pickling fluid for metal, acidic deg-reasing fluid, film treatment fluid	×	×
	Alkali	Alkali materials such as caustic soda, caustic potash, slaked lime, aqueous ammonia, sodium carbonate.	Water-soluble machining oil, leakage detecting agent	×	○
	Inorganic salt	Sodium sulfide, potassium nitrate, potassium dichromate, sodium sulfate, etc	Plating	×	○
Organic chemical	Aromatic hydro-carbon	Benzene, toluene, xylene, ethyl-benzene, styrene, etc	Included in paint thinner.	×	×
	Chlorinated aliphatic hydro-carbon	Methyl chloride, ethylene chloride, methylene chloride, acetylene chloride, chloroform, trichlene, berklene, carbon tetrachloride	Organic solvent cleaning fluid for metal	×	○
	Chlorinated hydro-carbon	Chloro-benzene, dichloro-benzene, Hexachloro-ethane(B-H-C), etc.	Agricultural chemical	×	○
	Petro-leum composition	Solvent naphtha, gasoline, kerosene	Degreasing for metal	×	○
	Alcohol	Methyl alcohol, ethyl alcohol, cyclohexanol, benzyl alcohol	Used in anti-freeze leakage detecting agent	×	×
	Phenol	Carbolic acid, cresol, naphthol, etc	Material for disinfection liquid	×	×
	Ether	Methyl ether, methyl ethyl ether, ethyl ether	Additive for brake fluid	×	○
	Ketone	Acetone, methyl ethyl ketone, cyclohexanone, acetophenone, etc		×	×
	Carbo-xylic acid	Formic acid, acetic acid, butyl acid, acrylic acid, oxalic acid, phthalic acid, etc	Aluminum treatment, paint-based material, leakage detecting agent	×	×
	Ester	Dimethyl phthalate(DMP), diethyl phthalate (DEP) dibutyl phthalate (DBP), dioctyl phthalate(DOP)	Additive for lubrication oil, synthetic hydraulic oil, rust preventive oil	×	○
	Hydroxy acid	Glycol acid, lactic acid, malic acid, citric acid, tartaric acid	Additive for food	×	×
	Nitro compound	Nitro methane, nitro ethane, nitro ethylene, nitro benzene		×	○
	Amine	Methyl-amine, dimethyl-amine, ethyl-amine, aniline, acetanilide, etc.	Additives for brake fluid, anti-static agent, dye for plastics	×	×
Nitrile	Acetonitrile, acrylonitrile, benznitrile, acetisonitrile, etc	Raw material for nitrile rubber	×	○	

○: Available, X: Not available (Plastic will break.)

2. 2 Piping

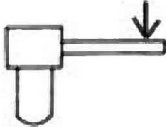
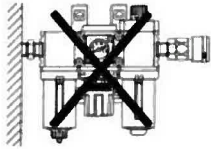
 WARNING	<p>Piping load torque the body or piping.</p> <p>Check that the piping load or torque is not applied to the body or piping sections.</p>													
	<table border="1" style="margin: auto; border-collapse: collapse;"> <thead> <tr> <th style="padding: 5px;">Series</th> <th style="padding: 5px;">1000-W</th> <th style="padding: 5px;">2000-W</th> <th style="padding: 5px;">3000-W</th> <th style="padding: 5px;">4000-W</th> <th style="padding: 5px;">6000-W</th> <th style="padding: 5px;">8000-W</th> </tr> </thead> <tbody> <tr> <td style="padding: 5px;">Max. torque N·m</td> <td style="text-align: center; padding: 5px;">15</td> <td style="text-align: center; padding: 5px;">15</td> <td style="text-align: center; padding: 5px;">50</td> <td style="text-align: center; padding: 5px;">50</td> <td style="text-align: center; padding: 5px;">100</td> <td style="text-align: center; padding: 5px;">100</td> </tr> </tbody> </table>	Series	1000-W	2000-W	3000-W	4000-W	6000-W	8000-W	Max. torque N·m	15	15	50	50	100
Series	1000-W	2000-W	3000-W	4000-W	6000-W	8000-W								
Max. torque N·m	15	15	50	50	100	100								
	<p>With the 1000 Series, application of a torque of 30 N·m or more on piping could damage piping. Use within the specified torque, even when using the piping adapter.</p>													
	<p>Avoid piping as followings.</p> <p>Avoid piping fixed with a single support, as this can result in excessive force and lead to damage.</p> <p>With the 1000 Series in particular, application of a torque of 30N·m and over on piping is "hazardous" as the piping could be damaged. Use within the specified torque, even when using the piping adapter.</p>													

 CAUTION	<ul style="list-style-type: none"> a) Flush the air piping to be used sufficiently before connecting the regulator. If dust or sealant enters the product during piping work, this may cause the product to malfunction or operate incorrectly. b) Install the Residual pressure release valve so as the arrow mark on the name plate of the valve matches the air flow direction. c) If dust or sealant enters the product during piping work, this may cause the product to decline in performance. d) When connecting the piping, tighten with proper tightening torque. e) Carefully connect the piping so that no bending moment caused by the piping load is applied to the product main body and piping.
--	--

(1) Flush air into the pipe to blow out foreign substances and chips before piping.

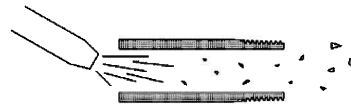

(2) Do not apply sealant or sealing tape for two pitches of thread from the tip of the pipe to avoid residual substances from falling into the piping system.

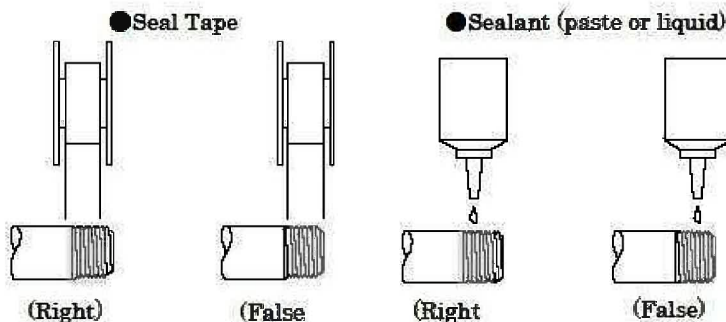

(3) Piping screw-in torque

Make sure that excessive torque is not applied on the body and piping when piping.

Series	1000-W	2000-W	3000-W	4000-W	6000-W	8000-W
Max. torque N·m	15	30	30	30	70	70

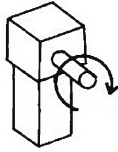

(4) Drain piping

- The drain piping for the plastic bowl has a barbed nipple, and can be directly installed. However, confirm that the drain cock is closed before inserting the tube.
- Cock is closed before inserting the tube.

(5) Tightening torque of drain cock

Max. tightening torque of drain cock of a plastic bowl is as follows.

- 1000-W Series: 0.1N·m
- Other: 0.5N·m

(6) Drain piping of metal bowl with automatic drain

Fix the cock's hexagonal face before screwing the joint, etc., into the drain port's female threads. When using the metal bowl with automatic drain, if the drain is piped with a tightening joint, manual operation is not possible.

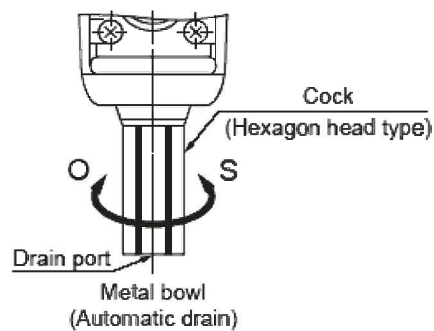

2. 3 Wiring of differential pressure switch

 CAUTION	<p>a)Wiring Please be sure that the wiring works are done after the electrical supply was cut. Before and during the wiring works, charged.</p> <p>b)Do not mistake wiring direction of differential pressure switch.The defect by which an LED lamp is for being not lit forms.</p> <p>c)Load resistance is necessary for a differential pressure switch.Please install load so that a load current and load voltage becomes in a use range.</p>
--	---

•Wiring of differential pressure switch

Please set the load resistance to become the current range of the following table.

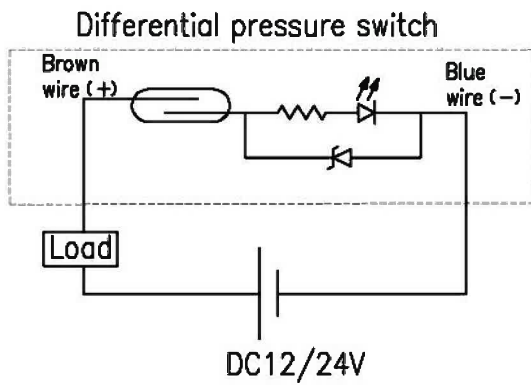

Load current

Rated voltage	Load current
DC24V	5~50mA
DC12V	5~50mA

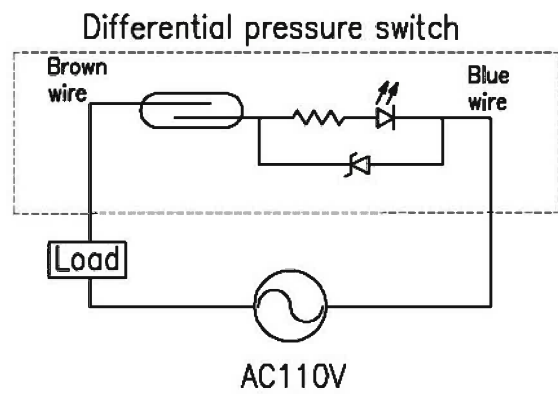

Load current

Rated voltage	Load current
AC110V	7~20mA

3. PROPER OPERATION

3. 1 Important Safety Instructions



WARNING

a) Circulate clean compressed air only.
If the compressed air contains chemicals or corrosive gas, malfunction or breakage of the product may result.

b) Operate the product within the specified pressure and temperature ranges in the correct flow direction. Failure to follow this instruction may result in breakage of the bowl or malfunction of terminal equipment.

(1) Maintain the throughput flow at or below the max. values specified in the charts below.

● M*00-W-M

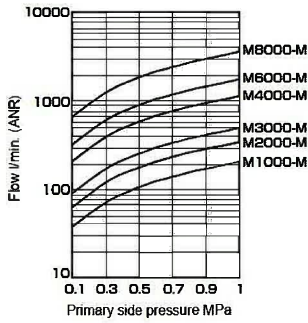

● M*00-W-S

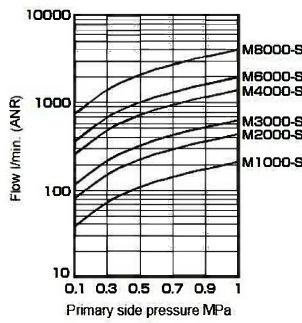

● M*00-W-X

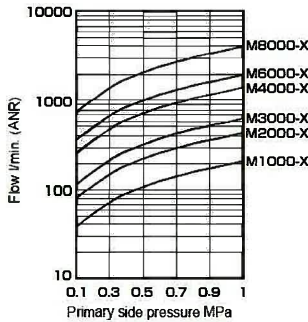

● M1000-W-F1
With automatic drain (M type, S type)

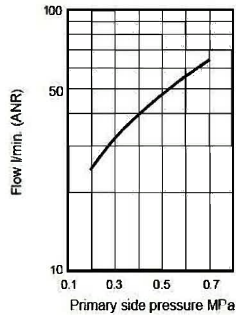

● MX*000-W

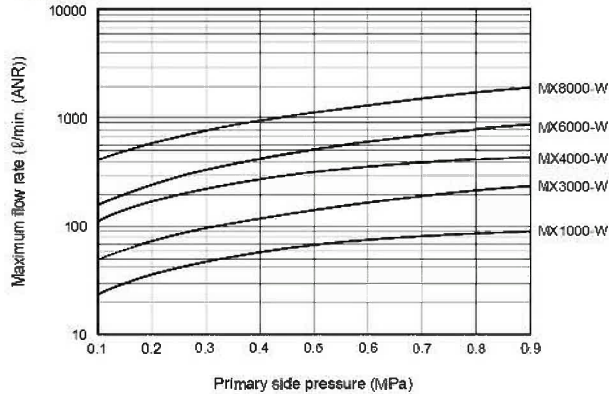

(2) Do not allow more than the rated flow even temporarily or install the oil mist filter where there is strong pulsation. Failure to pay attention to this instruction may result in breakage of the mantle, or result in oil or drainage reaching the secondary side, causing malfunction of the terminal equipment.

(3) Install a pre-filter(S type) on the primary side of the oil mist filter to prevent premature clogging.

(4) The primary oil concentration is 30 mg/m³ or less.

- (5) For the service life or replacement of the mantle, see Chapter 4. MAINTENANCE.
- (6) The minimum working pressure for the filter with an optional auto drain is 0.15 MPa.
(With M1000-W-F1 automatic drain, minimum operating pressure is 0.2 MPa, maximum operation pressure is 0.7 MPa)

■ Use the auto-drain under the working conditions below. Failure to observe this could result in operation faults.

- (1) Set the working pressure to 0.15 MPa or more. For 1000 Series NC auto-drain.
- (2) Set the working flow rate to less than or equal to the max. Working flow rate
- (3) Avoid use of this in places with high vibration, such as where a compressor is installed, because air could leak from the drain outlet when the float vibrates.
- (4) Avoid drain overflow, which may lead to malfunctions.

 CAUTION	Be sure to properly treat drainage collected in the bowl to avoid environmental pollution.
--	--

3. 2 Installation of differential pressure detection

3. 2. 1 Differential pressure gauge

CKD recommends installation of a differential pressure gauge for measuring the remaining life of the mantle (element) of your oil mist filter. CKD's differential pressure gauge (GA400-8-P02) is recommended for this purpose.

<Installation example of 1000-W series>

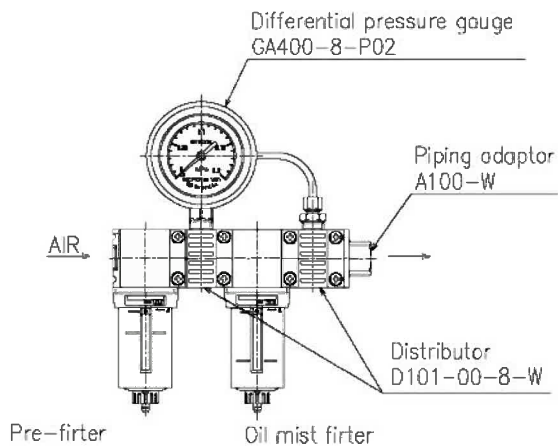

<Installation example of 2000-W, 3000-W, 4000-W series>

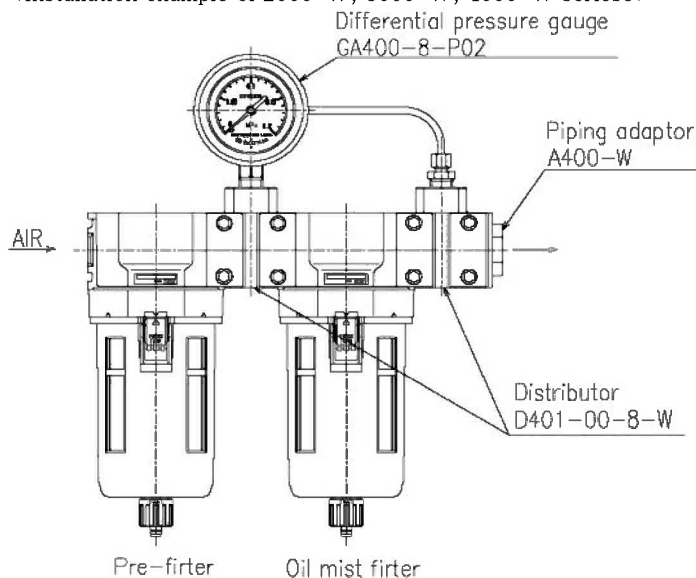

<Installation example of 6000-W, 8000-W series>

Pressure detection port is available as option for 6000-W, 8000-W series.

Check high- and low-pressure port positions for the differential pressure installation port, and install correctly.

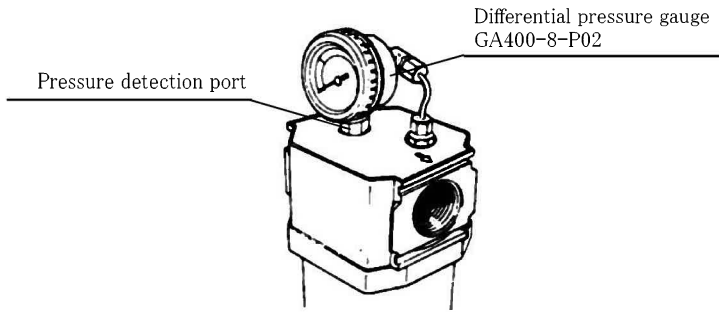

3. 2. 2 Differential pressure switch

 CAUTION	<p>a) Do not move or swing the product by lead wire on the differential pressure switch. This may lead to failure.</p> <p>b) Do not pull on the lead wire of the differential pressure switch with excessive force. This may lead to failure.</p> <p>c) There is no output holding mechanism in the differential pressure switch. Note that when stopping the unit or other times when air is not flowing through the filter, output will turn off. (When holding the output, consider a holding circuit on the fluid control components side.)</p> <p>d) The differential pressure switch may malfunction if there is a magnetic substance such as a steel plate installed nearby. Check that a distance of 10mm or more is provided from the surface of the indicator.</p> <p>e) Do not disassemble or modify the product. The differential pressure switch's detection accuracy will be reduced. Take particular care, since no additions can be made to differential pressure switch's Q2 and Q3.</p> <p>f) When connecting an inductive load (relay, etc.) or capacitive load, the contact service life may be reduced due to surge voltage or rush current. Install a contact protection circuit before use.</p> <p>g) Usage in an environment with a strong magnetic field may lead to malfunction of the differential pressure switch. Do not use this product in strong magnetic field environments.</p>
--	---

The differential pressure switch option detects a primary side and the differential pressure of the second side to occur by the clogging of the element and is an option to tell about deterioration by the electricity output. An indicator part is established in this option by default, and it is possible for the clogging confirmation by the viewing, too.

The life of the element is one year or time when differential pressure reached 0.1MPa. Please change the element if it becomes the life. As for the detection pressure of each SW, about 0.05MPa, SW2 become about 0.1MPa SW1.

I recommend the exchange of the element before all the colors of the output of SW2 or indicator part become red.

In addition, a differential pressure switch is optional, and there is the following variation.

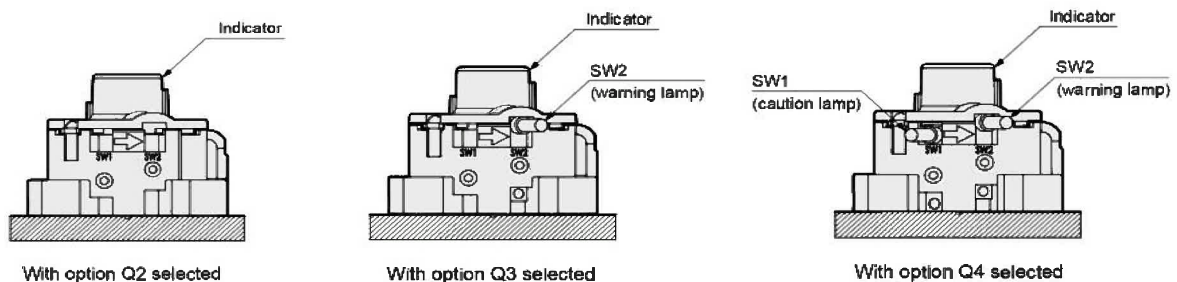

< THE INDICATOR SPECIAL QUALITY >

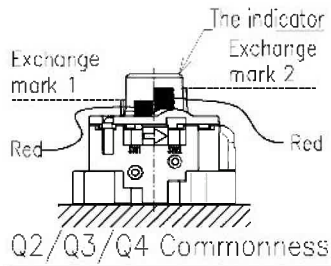

- When a red indicator reached exchange mark 1, it'll be mantle exchange recommendation time (the rule of thumb).
- When a red indicator reached exchange mark 2, it'll be mantle exchange indispensable time (the rule of thumb).

3. 3 Installation

(1) In case of making use of the C type bracket "BW" (optional, mount the regulator onto the C type bracket first, prior to screwing a piece of pipe into body of regulator. After aligning side grooves of body of regulator to the ridges on both sides of the C type bracket, push slide the bracket forcibly along the groove as per illustrated in the following figure.

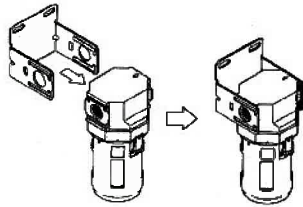

Slide C shape bracket sideways making its projected rail matching with the grooved rail on the unit.

- (2) Mount the oil mist filter so that its drain port settles downward.
- (3) Mount it in the upper steam of the pneumatic equipment to be serviced as close as possible.
- (4) Allow a clearance for maintenance under the bowl so that parts can be removed during disassembly.

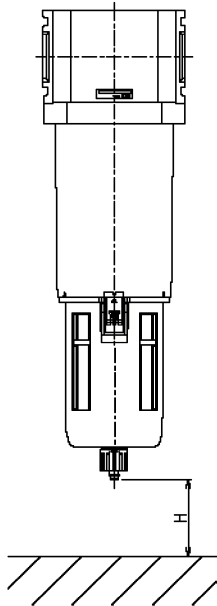

Model	Maintenance clearance H
1000-W~6000-W seriese	60mm or more
8000-W seriese	200mm or more

 WARNING	Be sure to firmly secure the product with specified brackets, fixing feet, and pipe supports, otherwise the product may shake under pressure, causing an accident.
--	--

4. MAINTENANCE

4. 1 Periodic Inspection

 WARNING	<p>a) Regularly, once or more in six months, check the air plastic bowl for cracks, damage, and other deterioration. Cracks, damage or other deterioration could result in breakage, so if found, replace with a new bowl or with a metal bowl.</p> <p>b) Check the plastic bowl periodically for contamination.</p> <ul style="list-style-type: none"> • If parts are heavily contaminated or if transparency has dropped, replace with a new bowl. • Use a diluted neutral household detergent to wash parts, and then rinse well with clean water. Use of other agents could result in breakage.
--	---

(1) Drain the oil mist filter regularly so that the accumulated drainage does not exceed the upper limit.

(2) Replace the mantle (element) with a new one on a regular basis in order to maintain cleanliness.

● Oil mist filter with "no symbol" (M type mantle)

Filters with this type of mantle cannot be reused after washing.

Replace after one year of use (6,000 hours) or when the pressure drops about 0.1MPa.

● Oil mist filter S (S type mantle)

Filters with this type of mantle cannot be reused after washing.

Replace after one year of use (6,000 hours) or when the pressure drops about 0.1MPa.

● Oil mist filter X (X type mantle)

Filters with this type of mantle cannot be reused after washing.

Simple guidelines for the timing of replacement cannot be provided as it depends on the concentration of odor components in the compressed air.

Initially, add up the hours from the start of operation to the moment where oil odor is detected in order to determine the life of the mantle. For subsequent use, replace the mantle when this period of time is reached.

● High performance oil mist filter

Filters with this type of mantle cannot be reused after washing.

Replace after one year of use (6,000 hours) or when the pressure drops about 0.1MPa.

(3) To maintain normal operation of auto drain "F1", clean the drain (by blowing air or washing with tap water) regularly or replace it.

(4) In case of option "Q1" (With differential pressure indicator), "Q2", "Q3", "Q4" (with differential pressure switch), replace the element before the differential pressure indicator becomes red.

(5) In case of option "Q3", "Q4" (with differential pressure switch), change the mantle (element) quickly when there is output from the differential pressure switch.

Components could malfunction or service life may decrease if oil concentration flows into the secondary side.

(6) In case of option "Q2", "Q3", "Q4" (with differential pressure switch), the mark formed on the clear cover for the indicator is a guideline for judgement during maintenance. Note that there may be discrepancies with the differential pressure output.

4. 2 Draining Out the Accumulated Sludge

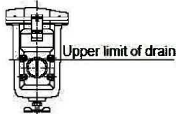
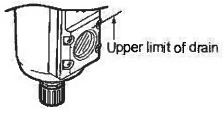
 <p>WARNING</p>	<p>a) Drain so that oil mist filter drainage does not accumulate Components could malfunction if drainage flows into the secondary side.</p> <div style="display: flex; justify-content: space-around; align-items: center;"> <div style="text-align: center;">  <p>Upper limit of drain</p> <p>Metal bowl</p> </div> <div style="text-align: center;">  <p>Upper limit of drain</p> <p>Metal bowl (M1 type)</p> </div> </div> <p>•The resin bowl must not be filled more than the "drain upper limit" or "MAX LEVEL" stamped on the bowl guard.</p> <p>b) Do not face the outlet when draining the bowl. Drainage may splash on your face and cause injury.</p>
---	---

Plastic bowl

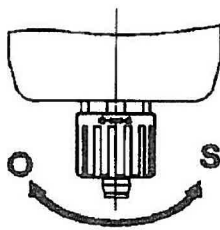

Drainage is started when the cock is turned to the O side, and the discharge is stopped when the cock is turned in the S direction. When the automatic drain is provided, drainage is discharged automatically when it accumulates. Drainage is also discharged manually.

Metal bowl (Automatic drain)

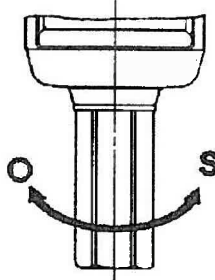

Drain is purged either automatically when accumulated or manually. Its operation is with the same principle as for plastic bowl. There are cases of unabling manually purge when tightening joint is piped.

Metal bowl (Manual cock)

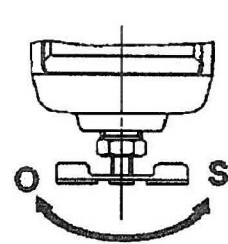

The cock is turned to the O side, and the discharge is stopped when the cock is turned in the S direction.

4. 3 Maintenance

 <p>WARNING</p>	<p>a) Before servicing the product, turn power OFF, stop the compressed air supply, and check that there is no residual pressure.</p> <p>b) Before removing the bowl, cut off the pressurized air and depressurize the bowl. Make sure that the bowl is completely depressurized.</p>
---	---

 <p>CAUTION</p>	<p>Read instructions and precautions enclosed with the product before starting use or maintenance.</p>
---	--

(1) Dismounting plastic bowl

2000-W, 3000-W, 4000-W, 6000-W, 8000-W series

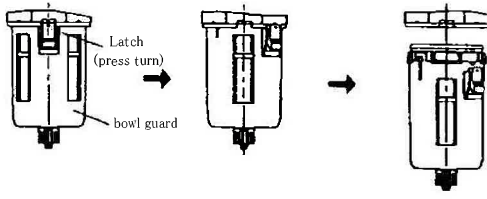

1000-W series

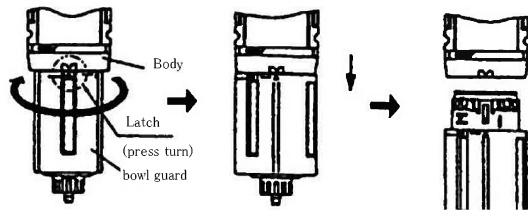

(2) Dismounting metal bowl

2000-W, 3000-W, 4000-W, 6000-W, 8000-W series

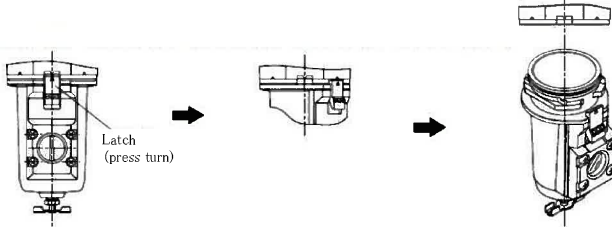

4. 4 Replacement offilter mantle (element)

 <p>CAUTION</p>	<p>Do not hold the center of the mantle (element) when moving and removing it. Failure to follow this instruction may result in breakage or poor performance of the product.</p>
--	--

< 1000-W series >

(1) Removing

Turn the mantle (element) to remove.

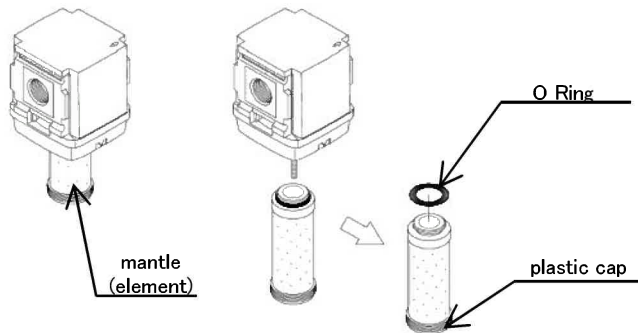

(2) Mounting

Mount the O-ring on the mantle (element).

Do not touch the urethane foam layer when replacing the mantle.

Turn the mantle (element) into the body until the top end of the mantle comes into contact with the body.

< 2000-W~8000-W series >

(1) Removing

Turn the mantle (element) to remove.

If the mantle cannot be manually loosened, it can be turned more easily by fitting a hexagonal bar wrench (nominal No. 6) in the hexagonal bottom indentation in the mantle (element).

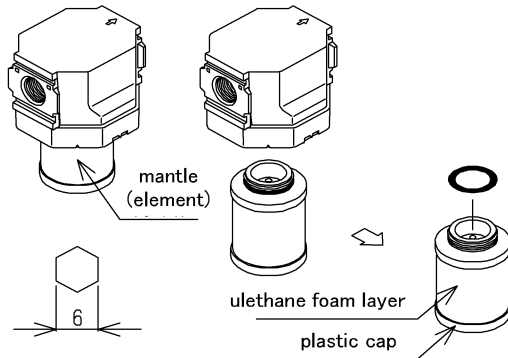

(2) Mounting

Turn the mantle (element) into the body.

Do not touch the urethane foam layer when replacing the mantle.

Tightening torque for mounting is 2.5 N·m.

4. 5 Expendable and Replacement Parts

Mantle (element) replacement parts

M※ series

Model	Blank (M type)	S (S type)	X (X type)
M1000-W	M1000-MANTLE-ASSY	M1000-MANTLE-ASSY-S	M1000-MANTLE-ASSY-X
M1000-F1-W	M1000-MANTLE-ASSY-F1	M1000-MANTLE-ASSY-F1S	-
M2000-W	M2000-MANTLE-ASSY	M2000-MANTLE-ASSY-S	M2000-MANTLE-ASSY-X
M3000-W	M3000-MANTLE-ASSY	M3000-MANTLE-ASSY-S	M3000-MANTLE-ASSY-X
M4000-W	M4000-MANTLE-ASSY	M4000-MANTLE-ASSY-S	M4000-MANTLE-ASSY-X
M6000-W	M6000-MANTLE-ASSY	M6000-MANTLE-ASSY-S	M6000-MANTLE-ASSY-X
M8000-W	M8000-MANTLE-ASSY	M8000-MANTLE-ASSY-S	M8000-MANTLE-ASSY-X

MX※ series

Model	Blank
MX1000-W	MX1000-MANTLE-ASSY
MX3000-W	MX3000-MANTLE-ASSY
MX4000-W	MX4000-MANTLE-ASSY
MX6000-W	MX6000-MANTLE-ASSY
MX8000-W	MX8000-MANTLE-ASSY

5. TROUBLESHOOTING

Phenomena	Major Causes	Remedies
Sludge comes out from directly after the filter.	Sludge (oil) accumulation has exceeded the max. drain level.	Drain sludge (oil) (See page 12.)
	Flow rate exceeds the maximum flow rate.	Replace with a model suitable for the flow rate.
Insufficient velocity. Remarkable pressure .	The life of the mantle(element) has expired.	Turn off the compressed air, remove the bowl and the mantle (element), and install a new mantle (element).
Sludge does not come out when open the drain cock.	Drain port has been clogged with foreign particles.	Remove the bowl, upon shutting air off, and replace it with new one or wash and rinse the cock.
Auto drain does not drain automatically. Air leaks from drain port.	Mechanical trouble of Auto drain or clogged with foreign particle.	Remove the bowl, upon shutting air off, and clean inside. Replace it with new ass'y unit when cleaning does not provide any remedy.
Air leaks at the hook up of a bowl.	The O-ring is damaged or has foreign matter on its surface.	Remove the bowl, upon shutting air off, and replace the O ring with new one or wash and rinse the packing.
	Bowl is defective.	Remove the bowl, upon shutting air off, and replace it with new one.

6. HOW TO ORDER AND PRODUCT SPECIFICATIONS

6.1 Product specifications

M※series

Model	M1000-W	M2000-W	M3000-W	M4000-W	M6000-W	M8000-W
Working fluid	Compressed air					
Working pressure range MPa	0.1~1.0 Note7、Note8					
Withstanding pressure MPa	1.5					
Drain capacity cm ³	3	25	45	80	80	80
Port size	1/8, 1/4	1/4, 3/8		1/4, 3/8, 1/2	3/4, 1	

Mantle option name		Blank(M type)	S(S type)	X(X type)
Maximum flow rate Note1 L/min(ANR)	M1000-W	150	150	150
	M2000-W	250	310	310
Primary pressure 0.7MPa	M3000-W	360	450	450
	M4000-W	825	1000	1000
Pressure drop 0.01MPa	M6000-W	1270	1400	1400
	M8000-W	2600	2900	2900
Ambient temperature range °C		5~60		
Filtration rating μm	0.01 μm (nominal)	0.3 μm		Note4 Suction by activated charcoal
Secondary side oil concentration mg/m ³	0.01 or less Note2、Note3	0.5 or less Note2		0.003 or less Note5
Mantle (element) change	1year(6000hours) or pressure drop 0.1MPa			- Note6

MX※series

Model	MX1000-W	MX3000-W	MX4000-W	MX6000-W	MX8000-W
Working fluid	Compressed air				
Working pressure range MPa	0.1~1.0 Note8				
Withstanding pressure MPa	1.5				
Drain capacity cm ³	3	45	80	80	80
Port size	1/8, 1/4	1/4, 3/8	1/4, 3/8, 1/2	3/4, 1	
Maximum flow rate Note1 L/min(ANR)	75	180	370	670	1480
Primary pressure 0.7MPa					
Pressure drop 0.01MPa					
Ambient temperature range °C		5~60			
Filtration rating μm	0.01 μm (nominal)				
Secondary side oil concentration mg/m ³	0.01 Note2、Note3				
Mantle (element) change	1year(6000hours) or pressure drop 0.1MPa				

Note 1: Use within the maximum processing flow rate.

If the maximum processing flow is exceeded temporarily, or if the filter is installed at a place with high levels of pulsation, the mantle could be damaged or oil or drainage, etc., could splatter to the secondary side and result in faults at the terminal.

Note 2: The secondary oil concentration is the value when the primary oil concentration is 30 mg/m³ and inlet air temperature is 21°C

Note 3: Install an oil mist filter (S type) as a prefilter on the primary side to prevent early clogging.

Note 4: Activated charcoal particles could flow to the secondary side, so install an air filter (F Series) or oil mist filter (M Series M type or S type) on the secondary side.

Note 5: When an oil mist filter (M Series M type) is installed on the primary side.

Note 6: The mantle (element) replacement period differs with the odor density in compressed air, and thus cannot be clearly indicated. Consider the total period from initial installation to when the smell of oil is confirmed as the effective deodorizing period, and replace at the same time as the M type or control with usage time.

(When the inlet temperature is 21 , replace at the control time or 1,000 hours, whichever is sooner)

Keep the primary air temperature at 30 or less. The deodorizing effect will drop if the temperature is high, so provide heat dissipation measures.

Note 7: With M1000-W-F1 automatic drain, minimum operating pressure is 0.2 MPa, maximum operation pressure is 0.7 MPa and withstanding pressure is 1.05MPa.

Note 8: When "F1" with an automatic drain is selected, minimum operation pressure must be 0.15MPa.

6.2 Differential pressure switch specifications

Differential pressure switch options	Differential pressure switch Q3/Q4	
	Reed 2-wire method	
Load voltage	12/24 VDC	110VAC
Load current *1	5 to 50mA	7 to 20mA
internal voltage drop	3V or less	
indicator lamp	Red LED(Lit when ON)	
Lead wire length	3m(Oil resistant vinyl cabtyre cable 2-conductor 0.2mm ²)	
Shock resistance	294m/s ²	
Insulation resistance	20MΩ and over with 500VDC megger	
Withstand voltage	No failure after 1minute of 1000VAC application	
Degree of protection	IEC Standard IP67,JIS C09208water-tight),oil resistance	
Contact protection circuit	None	

*1 Install the load resistance before use.

CE making specifications

Compatible as standard.

6.3 Option mass table

Model	draining of sludge	Materials of bowl		Differential pressure indicator	Differential pressure switch				Piping adaptor set							Bracket
	F1	M	M1		Q1	Q2	Q3	Q4	A6※W	A8※W	A10※W	A15※W	A20※W	A25※W	A32※W	
M1000	0.007							0.09	0.09	0.09						0.10
M2000	0.02		0.1			0.04	0.09	0.13		0.16	0.16	0.16				0.15
M3000	0.02	0.1	0.1			0.04	0.09	0.13		0.16	0.16	0.16				0.17
M4000	0.02	0.1	0.1	0.024		0.05	0.10	0.14		0.16	0.16	0.16	0.16			0.21
M6000	0.02	0.1	0.1			0.05	0.10	0.14					0.53	0.53	0.53	0.34
M8000	0.02	0.1	0.1										0.53	0.53	0.53	0.36

6. 3 How to order

M※Series

•How to order

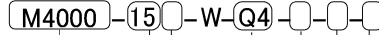

A Model No

A Model No.					
M	M	M	M	M	M
1	2	3	4	6	8
0	0	0	0	0	0
0	0	0	0	0	0
0	0	0	0	0	0

Symbol	Descriptions						
B Port size							
6	1/8	●					
8	1/4	●	●	●	●		
10	3/8		●	●	●		
15	1/2			●	●		
20	3/4				●	●	
25	1					●	●

C Port thread type							
Blank	Rc thread	●	●	●	●	●	●
N	NPT thread	●	●	●	●	●	●
G	G thread	●	●	●	●	●	●

D Option							
Drain discharge	Blank	With manual drain cock	●	●	●	●	●
	F 1	Auto-drain with manual override (NG: No exhaust when not pressurized)	●	●	●	●	●
Bowl material	Blank	Polycarbonate bowl	●	●	●	●	●
	Z	Nylon bowl	●	●	●	●	●
	M	Metal bowl					
Mantle (element)	M 1	Metal bowl with manual drain cock	●	●	●	●	●
	Blank	M type (nominal 0.01 μm; remaining oil 0.01 mg/m ³)	●	●	●	●	●
	S	S type (nominal 0.3 μm; remaining oil 0.5 mg/m ³)	●	●	●	●	●
Differential pressure detection	X	X type (deodorization; remaining oil 0.003mg/m ³)	●	●	●	●	●
	Blank	Without differential pressure indicator or switch	●	●	●	●	●
	Q	With differential pressure detection port (Rc1/4)					●
	Q 1	Differential pressure indicator				●	
	Q 2	Differential pressure indicator			●	●	
Flow direction	Q 3	Differential pressure indicator +switch 1-point (SW2)			●	●	
	Q 4	Differential pressure indicator +switch 2-point (SW1/SW2)			●	●	
	Blank	Standard flow (left→right)	●	●	●	●	●
X 1	Reverse flow (right→left)	●	●	●	●	●	

E Display unit							
Blank	MPa display, Rc thread	●	●	●	●	●	●
J 1	MPa display, NPT, G thread	●	●	●	●	●	●

F Piping adaptor set (attached)							
Blank	Not attached	●	●	●	●	●	●
A 6※W	Rc 1 / 4 piping adaptor set	●	●	●	●		
A 8※W	Rc 1 / 4 piping adaptor set	●	●	●	●		
A 1 0※W	Rc 3 / 8 piping adaptor set		●	●	●		
A 1 5※W	Rc 1 / 2 piping adaptor set			●	●		
A 2 0※W	Rc 3 / 4 piping adaptor set				●	●	
A 2 5※W	Rc 1 piping adaptor set					●	●
A 3 2※W	Rc 1 1 / 4 piping adaptor set						●
※Adaptor screw type							
Blank	Rc thread	●	●	●	●	●	●
N	NPT thread	●	●	●	●	●	●
G	G thread	●	●	●	●	●	●

G Bracket (attached)							
Blank	Not attached	●	●	●	●	●	●
BW	C type bracket	●	●	●	●	●	●

- *1 "Q1~Q4" with differential pressure detection cannot be selected for port size "8" of model M4000.
- *2 G threads and NPT threads are available for IN,OUT and drain outlet (metal bowl with auto-drain).
- *3 Select options for drainage, bowl material and differential pressure detection. When selecting options for several items, list options in order from the top.
- *4 NO auto-drain cannot be selected.
- *5 Refer to page 10 for the auto-drain usage conditions.
- *6 "Q1~Q4" with differential pressure detection cannot be selected for bowl material "M".
- *7 "Q2~Q4" with differential pressure detection cannot be selected for bowl material "M1".
- *8 "X" mantle cannot be combined with F1 option or "Q1~Q4" (with differential pressure detection).

MX※Series

How to order



A Model No

A Model No.				
M	M	M	M	M
1	3	4	6	8
0	0	0	0	0
0	0	0	0	0
0	0	0	0	0

Symbol	Descriptions					
B Port size						
6	1/8	●				
8	1/4	●	●	●		
10	3/8		●	●		
15	1/2			●		
20	3/4				●	●
25	1				●	●

C Port thread type						
Blank	Rc thread	●	●	●	●	●
N	NPT thread	●	●	●	●	●
G	G thread	●	●	●	●	●

D Option						
Drain discharge	Blank	With manual drain cock	●	●	●	●
	F 1	Auto-drain with manual override (NO:No exhaust when not pressurized)	●	●	●	●
Bowl material	Blank	Polycarbonate bowl	●	●	●	●
	Z	Nylon bowl	●	●	●	●
	M	Metal bowl		●	●	●
	M 1	Metal bowl with manual drain cock		●	●	●
Differential pressure detection	Blank	Without differential pressure indicator or switch	●	●	●	●
	Q	With differential pressure detection port (Rc1/4)			●	●
Flow direction	Blank	Standard flow (left→right)	●	●	●	●
	X 1	Reverse flow(right→left)	●	●	●	●

E Display unit						
Blank	MPa display, Rc thread	●	●	●	●	●
J 1	MPa display, NPT, G thread	●	●	●	●	●

F Piping adaptor set(attached)						
Blank	Not attached	●	●	●	●	●
A 6※W	Rc 1 / 4 piping adaptor set	●				
A 8※W	Rc 1 / 4 piping adaptor set	●	●	●		
A 1 0※W	Rc 3 / 8 piping adaptor set	●	●	●		
A 1 5※W	Rc 1 / 2 piping adaptor set		●	●		
A 2 0※W	Rc 3 / 4 piping adaptor set			●	●	●
A 2 5※W	Rc 1 piping adaptor set				●	●
A 3 2※W	Rc 1 1 / 4 piping adaptor set				●	●

※Adaptor screw type						
Blank	Rc thread	●	●	●	●	●
N	NPT thread	●	●	●	●	●
G	G thread	●	●	●	●	●

G Bracket(attached)						
Blank	Not attached	●	●	●	●	●
BW	C type bracket	●	●	●	●	●

- *1 G threads and NPT threads are available for IN,OUT and drain outlet(matal bowl with auto-drain).
- *2 Select options for drainage,bowl material and differential pressure detection.When selecting options for several items,list options in order from the top.
- *3 NO auto-drain cannot be selected.
- *4 Refer to page 10 for the auto-drain usage conditions.
- *5 The pipe adaptor set and C type bracket cannot be used together.
- *6 The joiner set is enclosed with the pipe adaptor set.