

Refrigerated air dryer

Zero Aqua GT9000/GT9000W/GT9000WV Series

Added to the GT9000 (W) Series for use with 75kW



Features

- Heat exchanger with SUS rust-proof shell
- Uses eco-friendly refrigerant (R-407C)
- Left or right side can be freely wall-mounted
- Equipped with remote control, "abnormal" and "running" signal output

Series variation

Series		Rated conditions					Applicable air compressor (kW)										
		Pressure dew point (°C)	Inlet air pressure (MPa)	Ambient temperature (°C)	Inlet air temperature (°C)	Cooling water inlet temperature (°C)	NEW 75	90	120	150	190	240	300	380	450	710	960
Air cooling type	GT9000	10	0.7	32	40	—	●	●	●	●	●	●	●	●	—	—	
Water cooling type	GT9000W	10	0.7	32	40	32	●	●	●	●	●	●	●	●	—	—	
	GT9000WV	10	0.7	32	40	32	—	—	—	—	—	—	—	—	●	●	
Performance control							1/1 operation					Unit control (automatic 1/2 operation)		Inverter control			

! Prior to use, please read the safety precautions in "Refrigerated Air Dryer Zero Aqua GT9000/GT9000W Series (catalog No. CC-1022A)".

GT9000-GT9000W Series

Specifications

Model No.	GT9075	GT9075W
Applicable air compressor KW	75	
Working fluid	Compressed air	
Inlet air temperature °C	5~60	
Inlet air pressure MPa	0.1~0.98	
Cooling water inlet pressure MPa	—	0.2~0.74
Ambient temperature °C	2~40	2~45
Treating flow rate m ³ /min (ANR) 50/60Hz (Note 2)	10.4/12.3	11.0/13.0
Treating flow rate m ³ /min (compressor intake condition) 50/60Hz (Note 3)	10.9/12.9	11.5/13.6
Inlet air temperature °C	40	
Inlet air pressure MPa	0.7	
Cooling water inlet temperature °C	—	32
Cooling water volume m ³ /h 50/60Hz	—	1.5/1.7
Ambient temperature °C	32	
Outlet air pressure dew point °C	10 (Note 4)	
Power supply	Three phase 200/200-220 VAC	
Power consumption kW 50/60Hz (Note 5)	2.2/2.6, 2.7	1.8/2.0, 2.1
Operating current A 50/60Hz (Note 5)	8.7/8.4, 8.5	7.9/6.9, 7.0
Starting current A 50/60Hz	43.8/39.1	43.8/39.1
Refrigerant	R-407C	
Air inlet/outlet port size	Elbow union Rc2	Elbow union Rc2
Product weight kg	146	148
Exhaust heat kW 50/60Hz	6.9/8.2	—

Note 1: Outer panel: Quality cool white (Munsell No. 5GY7.5/0.5)

Base: Munsell No. N3.0

Note 2: ANR shows conditions where 20°C atmospheric pressure and relative humidity 65%.

Note 3: Value is taken after converting the air compressor intake condition at 32°C atmospheric pressure and 75% relative humidity.

Note 4: Please contact us regarding dew point performance guarantee.

Note 5: Values for power consumption and operating current are from rated conditions, and are not ensured values.

Note 6: Please avoid sudden pressure fluctuations. It may cause a failure. Please refer to the specifications and instruction manual for details.

How to order

GT9075 **W** - **G** - **AC380V**

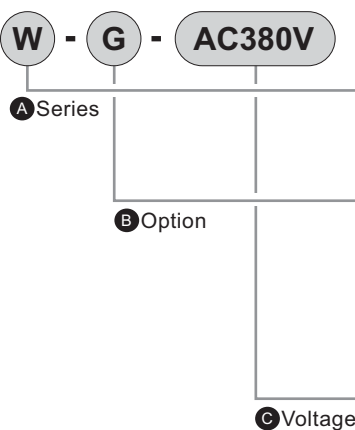

Symbol	Descriptions
(A) Series	
Blank	Air cooling type
W	Water cooling type
(B) Option	
Blank	Standard products
G	Optional voltage
H2	SUS name plate
H3	Simple export packaging
N1	Copper tube rust proof coating
(C) Voltage	
	200 VAC
	220 VAC (only 60Hz standard)
	230 VAC
	240 VAC
	380 VAC
	400 VAC
	415 VAC
	440 VAC
	480 VAC

⚠ Note on model No. selection

Note 1: Please indicate options in alphabetical order.

Note 2: Please indicate the voltage under section "C", even if a standard model is selected.

e.g.) GT9075-AC200V

Note 3: Option H3 uses plywood crate packaging.

Note 4: Instruction manual and name plate are written in Japanese and English.

Note 5: Please contact us if you need product photos.

Note 6: Please contact us if you need a specific body panel color.

How to order

● GT9000

(1) Temperature correction coefficient

Inlet air temperature (°C)		35		40		45	
Pressure dew point (°C)		10	15	10	15	10	15
Ambient temperature (°C)	25	1.29	1.29	1.14	1.24	0.91	0.99
	30	1.25	1.29	1.04	1.13	0.83	0.91
	32	1.20	1.29	1.00	1.09	0.80	0.87
	35	1.13	1.23	0.94	1.02	0.75	0.82
	40	1.01	1.10	0.84	0.92	0.67	0.73

Inlet air temperature (°C)		50		55		60	
Pressure dew point (°C)		10	15	10	15	10	15
Ambient temperature (°C)	25	0.69	0.75	0.46	0.50	0.23	0.25
	30	0.62	0.68	0.42	0.45	0.21	0.23
	32	0.60	0.65	0.40	0.44	0.20	0.22
	35	0.56	0.61	0.38	0.41	0.19	0.20
	40	0.50	0.55	0.34	0.37	0.17	0.18

(2) Inlet air pressure coefficient

Inlet air pressure (MPa)	0.10	0.20	0.30	0.40	0.50
Coefficient	0.60	0.66	0.73	0.80	0.87

Inlet air pressure (MPa)	0.60	0.70	0.80	0.90	0.98
Coefficient	0.93	1.00	1.07	1.13	1.19

If selecting the appropriate model based on the rated air capacity of each model

Rated air capacity × (1) Temperature correction coefficient ×

(2) Inlet air pressure coefficient = Maximum air capacity

Conditions	Working conditions	Selecting conditions	Coefficient
Inlet air temperature	30~38°C	40°C	0.94
Pressure dew point	10°C	10°C	
Ambient temperature	25~33°C	35°C	
Inlet air pressure	0.55~0.75MPa	0.5MPa	0.87
Frequency	50Hz	50Hz	50Hz

Substitute the above conditions into the equation above to obtain the air capacity when using the GT9075.

$$10.4 \times 0.94 \times 0.87 = 8.5\text{m}^3/\text{min (ANR)}$$

If the air consumption is less than this value, select that model.

Note 1: Select conditions in which the product value of each coefficient does not exceed 1.3.

Note 2: Please contact us regarding capabilities for pressure dew points below 10°C.

Dimensions

● GT9075

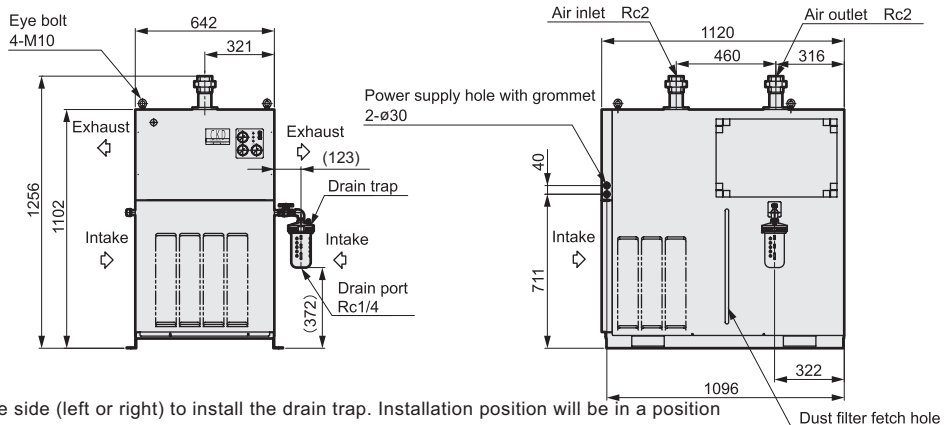
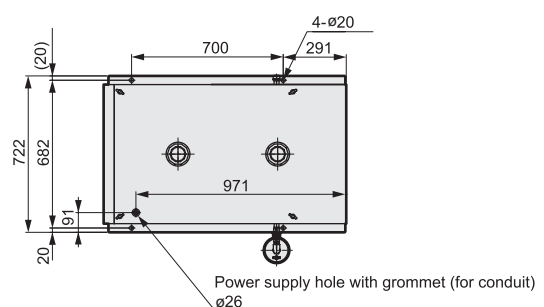
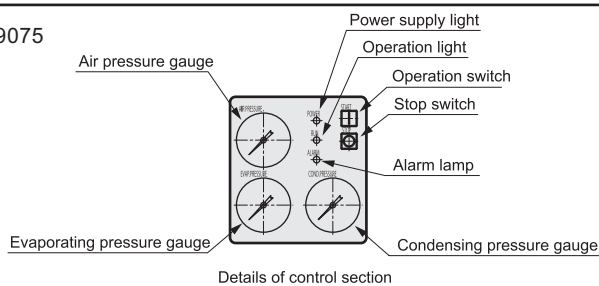

Note 1: You can select the side (left or right) to install the drain trap. Installation position will be in a position symmetrical to the left and right side.

Note 2: On GT9075, you can select the side (left or right) for the exhaust port.

● GT9000W

(1) Temperature correction coefficient

Inlet air temperature (°C)		35		40		45	
Pressure dew point (°C)		10	15	10	15	10	15
Coefficient		1.20	1.29	1.00	1.09	0.80	0.87

Inlet air temperature (°C)		50		55		60	
Pressure dew point (°C)		10	15	10	15	10	15
Coefficient		0.60	0.65	0.40	0.44	0.20	0.22

(2) Inlet air pressure coefficient

Inlet air pressure (MPa)	0.10	0.20	0.30	0.40	0.50
Coefficient	0.60	0.66	0.73	0.80	0.87

Inlet air pressure (MPa)	0.60	0.70	0.80	0.90	0.98
Coefficient	0.93	1.00	1.07	1.13	1.19

If selecting the appropriate model based on the rated air capacity of each model

Rated air capacity × (1) Temperature correction coefficient ×

(2) Inlet air pressure coefficient = Maximum air capacity

Conditions	Working conditions	Selecting conditions	Coefficient
Inlet air temperature	30~33°C	35°C	1.20
Pressure dew point	10°C	10°C	
Inlet air pressure	0.55~0.75MPa	0.5MPa	0.87
Frequency	50Hz	50Hz	50Hz

Substitute the above conditions into the equation above to obtain the air capacity when using the GT9075W.

$$11.0 \times 1.20 \times 0.87 = 11.5\text{m}^3/\text{min (ANR)}$$

If the air consumption is less than this value, select that model.

Note 1: Select conditions in which the product value of each coefficient does not exceed 1.3.

Note 2: Please contact us regarding capabilities for pressure dew points below 10°C.

GT9000-GT9000W Series

Dimensions

●GT9075W

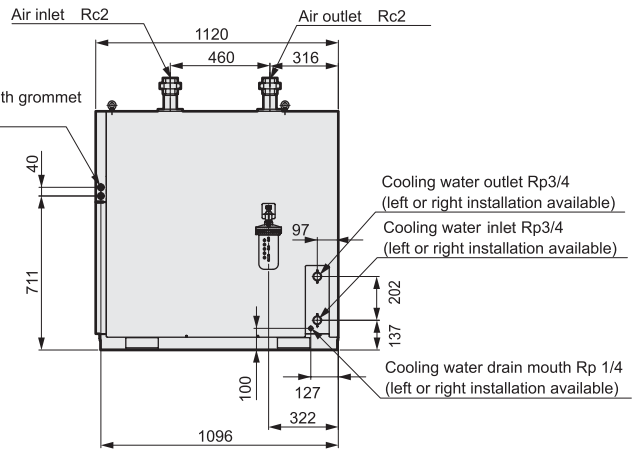
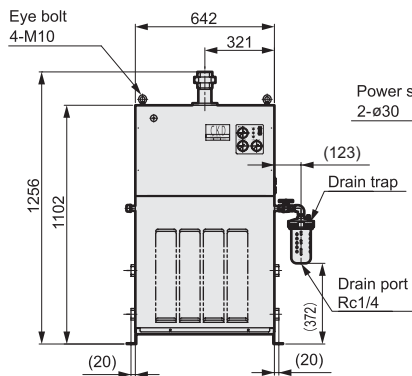
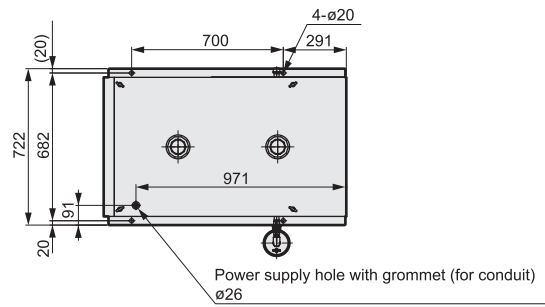
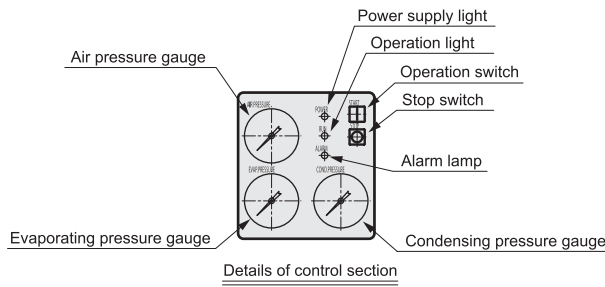

Note 1: You can select the side (left or right) to install the drain trap. Installation position will be in a position symmetrical to the left and right side.

Note 2: On GT9075W, you can select the side (left or right) to install the cooling water pipe. Installation position will be in a position symmetrical to the left and right side.

Accessories (Optional)

■Anchor bolt

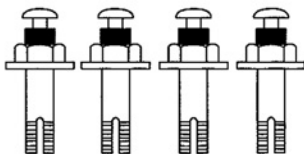

Anchor bolt: 4 SUS bolts per set

Products No.		RD-QFL-436465
Applicable model	Size	M16 × L100
GT9075	GT9075W	○

If the goods and their replicas, or the technology and software in this catalog are to be exported, laws require the exporter to make sure they will never be used for the development or the manufacture of weapons for mass destruction.

CKD Corporation

<Website>
<http://www.ckd.co.jp/>

Head Office-Plant 2-250, Uji, Komaki, Aichi 485-8551
 Sales And Marketing Div. 2-250, Uji, Komaki, Aichi 485-8551
 Overseas Sales Administration dpt. 2-250, Uji, Komaki, Aichi 485-8551

Overseas Business div. Tokyo Branch Office 4F, Bunkahousou Media Plus, 1-31-1, Hamamatsu-cho, Minato-ku, Tokyo 105-0013

Nagoya Branch Office 2-250, Uji, Komaki, Aichi 485-8551
 Osaka Branch Office 1-3-20, Tosabori, Nishi-ku, Osaka 550-0001

TEL(0568)77-1111 FAX(0568)77-1123
 TEL(0568)74-1303 FAX(0568)77-3410
 TEL(0568)74-1338 FAX(0568)77-3461

TEL(03)5402-3620 FAX(03)5402-0120

TEL(0568)74-1356 FAX(0568)77-3317
 TEL(06)6459-5770 FAX(06)6446-1945